



MOTOROLA

intelligence everywhere™

GP328 Plus/GP338 Plus/GP338 XLS Portable Radios

Detailed Service Manual

6804112J28-G

December, 2004

Computer Software Copyrights

The Motorola products described in this manual may include copyrighted Motorola computer programs stored in semiconductor memories or other media. Laws in the United States and other countries preserve for Motorola certain exclusive rights for copyrighted computer programs, including the exclusive right to copy or reproduce in any form, the copyrighted computer program. Accordingly, any copyrighted Motorola computer programs contained in the Motorola products described in this manual may not be copied or reproduced in any manner without the express written permission of Motorola. Furthermore, the purchase of Motorola products shall not be deemed to grant, either directly or by implication, estoppel or otherwise, any license under the copyrights, patents or patent applications of Motorola, except for the normal non-exclusive royalty-free license to use that arises by operation of law in the sale of a product.



©2000, 2001, 2002, 2003, 2004 by Motorola, Inc.
Motorola Technology Sdn. Bhd. (Co. No. 455657-H)
Plot 2, Bayan Lepas Technoplex Industrial Park,
Mukim 12, S.W.D.,
11900 Penang, Malaysia

Printed in Malaysia
December, 2004

DOCUMENT HISTORY

The following major changes have been implemented in this manual since the previous edition:

Edition	Description	Date
6804112J28-O	Initial edition	Sept. 2000
6804112J28-A	Updated Safety Information (June 2001). Updated controller board for VHF and UHF Band 1. Updated RF board for VHF and UHF Band 2.	Aug. 2001
6804112J28-B	Added Display Model (GP338 Plus) information.	Sept, 2001
6804112J28-C	Section 5A, 5B, 5C and 5D: Added new board diagrams, schematics and parts lists to VHF, UHF Band 1, UHF Band 2 and 330MHz sections.	Mar, 2002
6804112J28-D	Document History Section added.	June, 2003
	Changed to Safety Information (Feb. 2002).	
	Section 1: Introduction Updated CGISS Indirect Business Customer Help Desk information.	
	Section 5A, 5B and 5C: Model Chart & Test Specs Added 4 Channel information to VHF Band, UHF Band 1 and UHF Band 2 sections.	
6804112J28-E	Added GP338 XLS model. Changed to latest Safety Information (Feb. 2002) Corrected flex diagrams of GP328 Plus and GP338 Plus.	May, 2004
6804112J28-F	Updated Safety Information (Feb. 2002) Updated controller board (PCB no.8404051G07/G08) to 8404051G09 rev H.	Sept, 2004
6804112J28-G	Added controller board (PCB no.8404051G07/G08)	Dec, 2004

THIS PAGE INTENTIONALLY LEFT BLANK

Safety Information

Product Safety and RF Energy Exposure for Portable Two-Way Radios

The information provided in this document supersedes the general safety information published prior to **February 2002**.

 <p>Caution</p>	<p>BEFORE USING THIS RADIO, READ THE FOLLOWING INFORMATION WHICH CONTAINS IMPORTANT OPERATING INSTRUCTIONS FOR SAFE USAGE AND RF ENERGY AWARENESS AND CONTROL INFORMATION AND OPERATIONAL INSTRUCTIONS FOR COMPLIANCE WITH RF ENERGY EXPOSURE LIMITS IN APPLICABLE NATIONAL AND INTERNATIONAL STANDARDS. ALSO READ THE OPERATIONAL INSTRUCTIONS FOR SAFE USAGE. FOR RADIOS THAT HAVE BEEN APPROVED AS INTRINSICALLY SAFE, READ THE INSTRUCTIONS AND INFORMATION ON INTRINSIC SAFETY ON PAGE vii.</p>
--	--

RF Energy Exposure Awareness and Control Information and Operational Instructions for Occupational Use

NOTICE: This radio is intended for use in occupational/controlled conditions where users have full knowledge of their exposure and can exercise control over their exposure to meet the occupational limits in FCC and International standards. This radio device is **NOT** authorized for general population or consumer use.

This two-way radio uses electromagnetic energy in the radio frequency (RF) spectrum to provide communications between two or more users over a distance. It uses radio frequency (RF) energy or radio waves to send and receive calls. RF energy is one form of electromagnetic energy. Other forms include, but are not limited to, sunlight and x-rays. RF energy, however, should not be confused with these other forms of electromagnetic energy, which when used improperly, can cause biological damage. Very high levels of x-rays, for example, can damage tissues and genetic material.

Experts in science, engineering, medicine, health, and industry work with organizations to develop standards for safe exposure to RF energy. These standards provide recommended levels of RF exposure for both workers and the general public. These recommended RF exposure levels include substantial margins of protection.

All Motorola two-way radios are designed, manufactured, and tested to ensure they meet government-established RF exposure levels. In addition, manufacturers also recommend specific operating instructions to users of two-way radios. These instructions are important because they inform users about RF energy exposure and provide simple procedures on how to control it.

Please refer to the following websites for more information on what RF energy exposure is and how to control your exposure to assure compliance with established RF exposure limits:

<http://www.fcc.gov/oet/rfsafety/rf-faqs.html>

<http://www.osha.gov/SLTC/radiofrequencyradiation/index.html>

Federal Communication Commission (FCC) Regulations

The FCC rules require manufacturers to comply with the FCC RF energy exposure limits for portable two-way radios before they can be marketed in the U.S. When two-way radios are used as a consequence of employment, the FCC requires users to be fully aware of and able to control their exposure to meet occupational requirements. Exposure awareness can be facilitated by the use of a product label directing users to specific user awareness information. Your Motorola two-way radio

has a RF exposure product label. Also, your Motorola user manual, or separate safety booklet includes information and operating instructions required to control your RF exposure and to satisfy compliance requirements.

Compliance with RF Exposure Standards

Your Motorola two-way radio is designed and tested to comply with a number of national and International standards and guidelines (listed below) for human exposure to radio frequency electromagnetic energy. This radio complies with the IEEE (FCC) and ICNIRP exposure limits for occupational/controlled RF exposure environments at operating duty factors of up to 50% talk-50% listen and is authorized by the FCC for occupational use only.

In terms of measuring RF energy for compliance with these exposure guidelines, your radio generates measurable RF energy only while it is transmitting (during talking), not when it is receiving (listening) or in standby mode.

NOTE:The approved batteries, supplied with this radio, are rated for a 5-5-90 duty factor (5% talk-5% listen-90% standby) even though this radio complies with FCC occupational exposure limits and may operate at duty factors of up to 50% talk.

Your Motorola two-way radio complies with the following RF energy exposure standards and guidelines:

- United States Federal Communications Commission, Code of Federal Regulations; 47CFR part 2 sub-part J
- American National Standards Institute (ANSI) / Institute of Electrical and Electronic Engineers (IEEE) C95. 1-1992
- Institute of Electrical and Electronic Engineers (IEEE) C95.1-1999 Edition
- International Commission on Non-Ionizing Radiation Protection (ICNIRP) 1998
- Ministry of Health (Canada) Safety Code 6. Limits of Human Exposure to Radiofrequency Electromagnetic Fields in the Frequency Range from 3 kHz to 300 GHz, 1999
- Australian Communications Authority Radiocommunications (Electromagnetic Radiation - Human Exposure) Standard, 2003
- ANATEL ANNEX to Resolution No. 303 of July 2, 2002 "Regulation of limitation of exposure to electrical, magnetic and electromagnetic fields in the radio frequency range between 9 KHz and 300 GHz" and "Attachment to resolution # 303 from July 2, 2002" "Additional Requirements for SMR, Cellular and PCS Product Certification"

RF Exposure Compliance and Control Guidelines and Operating Instructions

To control your exposure and ensure compliance with the occupational/controlled environment exposure limits, always adhere to the following procedures.

Guidelines:

- Do not remove the RF Exposure Label from the device.
- User awareness instructions should accompany device when transferred to other users.
- Do not use this device if the operational requirements described herein are not met.

Operating Instructions

- Transmit no more than the rated duty factor of 50% of the time. To transmit (talk), push the Push-To-Talk (PTT) button. To receive calls, release the PTT button. Transmitting 50% of the time, or less, is important because this radio generates measurable RF energy exposure only when transmitting (in terms of measuring for standards compliance).

- Hold the radio in a vertical position in front of the face with the microphone (and other parts of the radio including the antenna) at least one inch (2.5 centimeters) away from the nose or lips.
- Antenna should be kept away from the eye. Keeping the radio at a proper distance is important since RF exposures decrease with increasing distance from the antenna.
- When worn on the body, always place the radio in a Motorola-approved clip, holder, holster, case, or body harness for this product. Using approved body-worn accessories is important because the use of non-Motorola-approved accessories may result in exposure levels, which exceed the FCC occupational/controlled environment RF exposure limits.
- If you are not using a body-worn accessory and are not using the radio in the intended use position in front of the face, ensure the antenna and the radio are kept at least one inch (2.5 centimeters) from the body when transmitting. Keeping the radio at a proper distance is important because RF exposures decrease with increasing distance from the antenna.



Approved Accessories

- Use only Motorola-approved supplied or replacement antennas, batteries, and accessories. Use of Non-Motorola approved antennas, batteries, and accessories may exceed the FCC (IEEE) and ICNIRP RF exposure guidelines.
- For a list of Motorola-approved accessories, visit the following website, which lists approved accessories for your radio model: <http://ap.cgiss.motorola.com/AAD/index.html>.

Additional Information

For additional information on exposure requirements or other training information, visit <http://www.motorola.com/rfhealth>.

Electromagnetic Interference/Compatibility

NOTE:Nearly every electronic device is susceptible to electromagnetic interference (EMI) if inadequately shielded, designed, or otherwise configured for electromagnetic compatibility.

Facilities

To avoid electromagnetic interference and/or compatibility conflicts, turn off your radio in any facility where posted notices instruct you to do so. Hospitals or health care facilities may be using equipment that is sensitive to external RF energy.

Aircraft

When instructed to do so, turn off your radio when on board an aircraft. Any use of a radio must be in accordance with applicable regulations per airline crew instructions.

Medical Devices

Pacemakers

The Advanced Medical Technology Association (AdvaMed) recommends that a minimum separation of 6 inches (15 centimeters) be maintained between a handheld wireless radio and a pacemaker. These recommendations are consistent with those of the U.S. Food and Drug Administration.

Persons with pacemakers should:

- ALWAYS keep the radio more than 6 inches (15 centimeters) from their pacemaker when the radio is turned ON.

- Not carry the radio in the breast pocket.
- Use the ear opposite the pacemaker to minimize the potential for interference.
- Turn the radio OFF immediately if there is any reason to suspect that interference is taking place.

Hearing Aids

Some digital wireless radios may interfere with some hearing aids. In the event of such interference, you may want to consult your hearing aid manufacturer to discuss alternatives.

Other Medical Devices

If you use any other personal medical device, consult the manufacturer of your device to determine if it is adequately shielded from RF energy. Your physician may be able to assist you in obtaining this information.

Use of communication devices while driving

Always check the laws and regulations on the use of radios in the areas where you drive.

- Give full attention to driving and to the road.
- Use hands-free operation, if available.
- Pull off the road and park before making or answering a call, if driving conditions or regulations so require.

Operational Warnings



WARNING

For vehicle with air bags

Refer to vehicle manufacturer's manual prior to installation of electronic equipment to avoid interference with air bag wiring.

Do not place a portable radio in the area over an air bag or in the air bag deployment area. Air bags inflate with great force. If a portable radio is placed in the air bag deployment area and the air bag inflates, the radio may be propelled with great force and cause serious injury to occupants of the vehicle.

Potentially Explosive Atmospheres

(Explosive atmospheres refers to hazard classified locations that may contain hazardous gas, vapors, or dusts.)

Turn off your radio prior to entering any area with a potentially explosive atmosphere unless it is a portable radio type especially qualified for use in such areas as Intrinsically Safe (for example, Factory Mutual, CSA, UL, or CENELEC).

Do not remove, install, or charge batteries in such areas. Sparks in a potentially explosive atmosphere can cause an explosion or fire resulting in bodily injury or even death.

The areas with potentially explosive atmospheres referred to above include fueling areas such as below decks on boats, fuel or chemical transfer or storage facilities, and areas where the air contains chemicals or particles such as grain, dust or metal powders. Areas with potentially explosive atmospheres are often, but not always, posted.

Blasting Caps And Blasting Areas

To avoid possible interference with blasting operations, turn off your radio when you are near electrical blasting caps, in a blasting area, or in areas posted: "Turn off two-way radio." Obey all signs and instructions.

Operational Cautions

 Caution	<p>Antennas</p> <p>Do not use any portable radio that has a damaged antenna. If a damaged antenna comes into contact with your skin, a minor burn can result.</p>
	<p>Batteries</p> <p>All batteries can cause property damage and/or bodily injury, such as burns, if a conductive material such as jewelry, keys, or beaded chains touches exposed terminals. The conductive material may complete an electrical circuit (short circuit) and become quite hot. Exercise care in handling any charged battery, particularly when placing it inside a pocket, purse, or other container with metal objects.</p>

Intrinsically Safe Radio Information

The Intrinsically safe approval unit refers to a product that has been approved as intrinsically safe by an approval agency (for example FM Approvals, CSA, UL, or Cenelec) and certifies that a particular product meets the Agency's applicable intrinsic safety standards for specific types of hazardous classified locations. A portable radio that has been approved for intrinsic safety will have Approval label attached to the radio to identify the unit as being Approved for specified hazardous atmospheres. This label specifies the hazardous Class/Division/Group along with the part number of the battery that must be used. The intrinsically safe approval label will be located on the portable radio unit.

Operational Cautions for Intrinsic Safe Equipment

 Caution	<ul style="list-style-type: none"> • Do not operate radio communications equipment in a hazardous atmosphere unless it is a type especially qualified (for example, FM, UL, CSA, or CENELEC approved). An explosion or fire may result. • Do not operate a radio unit that has been approved as intrinsically safe product in a hazardous atmosphere if it has been physically damaged (for example, cracked housing). An explosion or fire may result. • Do not replace or charge batteries in a hazardous atmosphere. Contact sparking may occur while installing or removing batteries and cause an explosion or fire.
---	--

Warnings for Radios Approved as Intrinsically Safe

Radios must ship from the Motorola manufacturing facility with the hazardous atmosphere capability and the intrinsic safety approval labelling (FM, UL, CSA, CENELEC). Radios will not be upgraded to this capability and labeled once they have been shipped to the field.

A modification changes the unit's hardware from its original design configuration. Modifications can only be made by the original product manufacturer.



WARNING

- **Do not replace or change accessories in a hazardous atmosphere. Contact sparking may occur while installing or removing accessories and cause an explosion or fire.**
- **Turn the radio off before removing or installing a battery or accessory.**
- **Do not disassemble an intrinsically safe product in any way that exposes the internal circuits of the unit.**
- **Failure to use an intrinsically safe approved battery or Approved accessories specifically approved for the radio unit may result in the dangerously unsafe condition of an unapproved radio combination being used in a hazardous location.**
- **Unauthorized or incorrect modification of the intrinsically safe approved Product will negate the approval rating of the product.**
- **Incorrect repair or relabeling of any intrinsically safe Agency approved radio could adversely affect the Approval rating of the unit.**
- **Use of a radio that is not intrinsically safe in a hazardous atmosphere could result in serious injury or death.**

Repair



WARNING

REPAIRS FOR MOTOROLA PRODUCTS WITH INTRINSICALLY SAFE APPROVAL ARE THE RESPONSIBILITY OF THE USER.

- **Repairs to a Motorola FM approved radio product should only be done at a location that has been FM audited under the FM 3605 repairs and service standard.**
- **Contact Motorola for assistance regarding repairs and service of Motorola intrinsically safe equipment.**

A repair constitutes something done internally to the unit that would bring it back to its original condition.

Items not considered as repairs are those in which an action is performed on a unit which does not require the outer casing of the unit to be opened in a manner that exposes the internal electrical circuits of the unit.

Do Not Substitute Options or Accessories

The Motorola communications equipment certified as intrinsically safe by the approving agency, (FM, UL, CSA, CENELEC) is tested as a complete system which consists of the listed agency Approved portable, Approved battery, and Approved accessories or options, or both. This Approved portable and battery combination must be strictly observed. There must be no substitution of items, even if the substitute has been previously Approved with a different Motorola communications equipment unit. Approved configurations are listed by the Approving Agency (FM, UL, CSA, CENELEC).

The intrinsically safe Approval label affixed to radio refers to the intrinsically safe classification of that radio product, and the approved batteries that can be used with that system.

The manual PN referenced on the intrinsically safe approval label identifies the approved Accessories and or options that can be used with that portable radio unit.

Using a non Motorola intrinsically safe battery and or accessory with the Motorola approved radio unit will void the intrinsically safe approval of that radio unit.

Table of Contents

Document History *i*

Safety Information *iii*

Section 1 *Introduction*

1.0 Scope of Manual.....	1-1
2.0 Warranty and Service Support.....	1-1
2.1 Warranty Period	1-1
2.2 After Warranty Period.....	1-1
2.3 Piece Parts	1-2
2.4 Technical Support	1-2
2.5 Further Assistance From Motorola	1-2

Section 2 *Service Aids*

1.0 Recommended Test Tools.....	2-1
---------------------------------	-----

Section 3 *Power Up Self-Test*

1.0 Error Codes	3-1
-----------------------	-----

Section 4 *Controller Information*

1.0 Overview.....	4-1
2.0 Radio Power Distribution	4-1
3.0 Controller Board.....	4-2
3.1 General.....	4-2
3.2 Digital Architecture	4-3
3.3 Keypad	4-5
3.4 Troubleshooting Chart.....	4-6
3.5 Controller Board Diagrams.....	4-7
Controller Board Top View (PCB No. 8404051G07/G08)	4-7
Controller Board Top View (PCB No. 8404051G07/G08)	4-8
Controller Board Top View (PCB No. 8404051G09)	4-9
Controller Board Bottom View (PCB No.8404051G09).....	4-10
3.6 Controller Schematics	4-11
Complete Controller Schematic Diagram	4-11
Controller ASFIC/ON_OFF Schematic Diagram	4-12
Controller Micro Processor Schematic Diagram	4-13
Controller Memory Schematic Diagram	4-14

Controller Audio Power Amplifier Schematic Diagram.....	4-15
Controller Parts List for VHF (for 8404051G07/G08 and 8404051G09).....	4-16
Controller Parts List for UHF 1, UHF 2 and 330MHz (for 8404051G07/G08 and 8404051G09).....	4-17
3.7 Controller Board Diagrams	4-18
Controller Board Top View (PCB No. 8404056G01).....	4-18
Controller Board Bottom View (PCB No.8404056G01)	4-19
Controller Board Top View (PCB No. 8404056G02).....	4-20
Controller Board Bottom View (PCB No. 8404056G02)	4-21
3.8 Controller Schematics.....	4-22
Complete Controller Schematic Diagram.....	4-22
Controller ASFIC/ON_OFF Schematic Diagram.....	4-23
Controller Micro Processor Schematic Diagram	4-24
Controller Memory Schematic Diagram	4-25
Controller Audio Power Amplifier Schematic Diagram.....	4-26
Controller Interface Schematic Diagram (for 8404056G01).....	4-27
Controller Interface Schematic Diagram (for 8404056G02).....	4-28
Controller Parts List for VHF (for 8404056G01/G02).....	4-29
Controller Parts List for UHF 1, UHF 2 and 330MHz (for 8404056G01/G02).....	4-31

Section 5A Model Chart and Test Specifications (136-174 Mhz)

1.0 Model Chart.....	5A-1
2.0 Specifications (for GP328 Plus)	5A-2
3.0 Specifications (for GP338 Plus/GP338 XLS)	5A-3
4.0 Transmitter	5A-4
4.1 General	5A-4
5.0 Receiver	5A-6
5.1 Receiver Front-End.....	5A-6
5.2 Receiver Back-End	5A-7
5.3 Automatic Gain Control Circuit	5A-8
6.0 Frequency Generation Circuitry	5A-9
6.1 Synthesizer	5A-10
6.2 VCO - Voltage Controlled Oscillator	5A-11
7.0 Notes For All Schematics and Circuit Boards	5A-13
8.0 Circuit Board/Schematic Diagrams and Parts List	5A-15
VHF (136-174MHz) Main Board Top Side PCB No. 8404055G05/G06/G07.....	5A-15
VHF (136-174MHz) Main Board Bottom Side PCB No. 8404055G05/G06/G07	5A-16
VHF (136-174MHz) Main Board Top Side PCB No. 8404055G09	5A-17
VHF (136-174MHz) Main Board Bottom Side PCB No. 8404055G09.....	5A-18
VHF Controls And Switches Schematic Diagram (sheet 1 of 2).....	5A-19
VHF Controls And Switches Schematic Diagram (sheet 2 of 2).....	5A-20
VHF Controls And Switches Schematic Diagram (sheet 2 of 2 for 8404055G09 PCB)	5A-21

VHF Receiver Front End Schematic Diagram	5A-22
VHF Receiver Back End Schematic Diagram	5A-23
VHF Synthesizer Schematic Diagram	5A-24
VHF Voltage Controlled Oscillator Schematic Diagram	5A-25
VHF Transmitter Schematic Diagram.....	5A-26
VHF Radio Parts List (RF Board)	5A-27
9.0 Troubleshooting Charts	5A-31
Troubleshooting Flow Chart for Controller	5A-31
Troubleshooting Flow Chart for Receiver (Sheet 1 of 2)	5A-32
Troubleshooting Flow Chart for Receiver (Sheet 2 of 2)	5A-33
Troubleshooting Flow Chart for Transmitter.....	5A-34
Troubleshooting Flow Chart for Synthesizer	5A-35
Troubleshooting Flow Chart for VCO	5A-36

Section 5B *Model Chart and Test Specifications (403-470 Mhz)*

1.0 Model Chart	5B-1
2.0 Specifications (for GP328 Plus).....	5B-2
3.0 Specifications (for GP338 Plus/GP338 XLS).....	5B-3
4.0 Transmitter.....	5B-4
4.1 General.....	5B-4
5.0 Receiver.....	5B-6
5.1 Receiver Front-End	5B-6
5.2 Receiver Back-End.....	5B-7
5.3 Automatic Gain Control Circuit	5B-8
6.0 Frequency Generation Circuitry.....	5B-9
6.1 Synthesizer.....	5B-10
6.2 VCO - Voltage Controlled Oscillator.....	5B-11
7.0 Notes For All Schematics and Circuit Boards.....	5B-13
8.0 Circuit Board/Schematic Diagrams and Parts List.....	5B-15
UHF (403-470MHz) Main Board Top Side PCB No. 8404077G05/G06/G07	5B-15
UHF (403-470MHz) Main Board Bottom Side PCB No. 8404077G05/G06/G07	5B-16
UHF (403-470MHz) Main Board Top Side PCB No. 8404077G09	5B-17
UHF (403-470MHz) Main Board Bottom Side PCB No. 8404077G09	5B-18
UHF Controls And Switches Schematic Diagram (sheet 1 of 2)	5B-19
UHF Controls And Switches Schematic Diagram (sheet 2 of 2 for 8404077G09 PCB).....	5B-20
UHF Receiver Front End Schematic Diagram.....	5B-21
UHF Receiver Back End Schematic Diagram	5B-22
UHF Synthesizer Schematic Diagram	5B-23
UHF Voltage Controlled Oscillator Schematic Diagram	5B-24
UHF Transmitter Schematic Diagram	5B-25
UHF Band 1 Radio Parts List (RF Board)	5B-26
9.0 Troubleshooting charts	5B-29

Troubleshooting Flow Chart for Controller	5B-29
Troubleshooting Flow Chart for Receiver (Sheet 1 of 2).....	5B-30
Troubleshooting Flow Chart for Receiver (Sheet 2 of 2).....	5B-31
Troubleshooting Flow Chart for Transmitter	5B-32
Troubleshooting Flow Chart for Synthesizer	5B-33
Troubleshooting Flow Chart for VCO	5B-34

Section 5C *Model Chart and Test Specifications (450-527 Mhz)*

1.0 Model Chart.....	5C-1
2.0 Specifications (for GP328 Plus)	5C-2
3.0 Specifications (for GP338 Plus/GP338 XLS)	5C-3
4.0 Transmitter	5C-4
4.1 General	5C-4
5.0 Receiver	5C-6
5.1 Receiver Front-End.....	5C-6
5.2 Receiver Back-End	5C-7
5.3 Automatic Gain Control Circuit	5C-8
6.0 Frequency Generation Circuitry	5C-9
6.1 Synthesizer	5C-10
6.2 VCO - Voltage Controlled Oscillator	5C-11
7.0 Notes For All Schematics and Circuit Boards	5C-13
8.0 Circuit Board/Schematic Diagrams and Parts List	5C-15
UHF Band 2 (450-527MHz) Main Board Top Side	
PCB No. 8404102G03/G04/G05	5C-15
UHF Band 2 (450-527MHz) Main Board Bottom Side	
PCB No. 8404102G03/G04/G05	5C-16
UHF Band 2 (450-527MHz) Main Board Top Side PCB No. 8404102G07.....	5C-17
UHF Band 2 (450-527MHz) Main Board Bottom Side PCB No. 8404102G07 ..	5C-18
UHF Band 2 Controls And Switches Schematic Diagram (sheet 1 of 2)	
UHF Band 2 Controls And Switches Schematic Diagram (sheet 2 of 2) ...	5C-19
UHF Band 2 Controls And Switches Schematic Diagram	
(sheet 2 of 2 for 8404102G07 PCB)	5C-21
UHF Band 2 Receiver Front End Schematic Diagram.....	5C-22
UHF Band 2 Receiver Back End Schematic Diagram	5C-23
UHF Band 2 Synthesizer Schematic Diagram	5C-24
UHF Band 2 Voltage Controlled Oscillator Schematic Diagram	5C-25
UHF Band 2 Transmitter Schematic Diagram.....	5C-26
UHF Band 2 Radio Parts List (RF Board)	5C-27
9.0 Troubleshooting charts.....	5C-31
Troubleshooting Flow Chart for Controller	5C-31
Troubleshooting Flow Chart for Receiver (Sheet 1 of 2).....	5C-32
Troubleshooting Flow Chart for Receiver (Sheet 2 of 2).....	5C-33
Troubleshooting Flow Chart for Transmitter	5C-34
Troubleshooting Flow Chart for Synthesizer	5C-35

Troubleshooting Flow Chart for VCO	5C-36
--	-------

Section 5D *Model Chart and Test Specifications (330-400 Mhz)*

1.0 Model Chart	5D-1
2.0 Specifications (for GP328 Plus).....	5D-2
3.0 Specifications (for GP338 Plus).....	5D-3
4.0 Transmitter.....	5D-4
4.1 General.....	5D-4
5.0 Receiver.....	5D-6
5.1 Receiver Front-End	5D-6
5.2 Receiver Back-End.....	5D-7
5.3 Automatic Gain Control Circuit	5D-8
6.0 Frequency Generation Circuitry.....	5D-9
6.1 Synthesizer.....	5D-10
6.2 VCO - Voltage Controlled Oscillator	5D-11
7.0 Notes For All Schematics and Circuit Boards.....	5D-13
8.0 Circuit Board/Schematic Diagrams and Parts List.....	5D-15
330-400MHz Main Board Top Side PCB No. 8404101G02/G03/G04.....	5D-15
330-400MHz Main Board Bottom Side PCB No. 8404101G02/G03/G04	5D-16
330-400MHz Main Board Top Side PCB No. 8404101G06	5D-17
330-400MHz Main Board Bottom Side PCB No. 8404101G06	5D-18
330-400MHz Controls And Switches Schematic Diagram (sheet 1 of 2)	5D-19
330-400MHz Controls And Switches Schematic Diagram (sheet 2 of 2)	5D-20
330-400MHz Controls And Switches Schematic Diagram (sheet 2 of 2 for 8404101G06 PCB).....	5D-21
330-400MHz Receiver Front End Schematic Diagram	5D-22
330-400MHz Receiver Back End Schematic Diagram.....	5D-23
330-400MHz Synthesizer Schematic Diagram.....	5D-24
330-400MHz Voltage Controlled Oscillator Schematic Diagram	5D-25
330-400MHz Transmitter Schematic Diagram	5D-26
330-400MHz Radio Parts List (RF Board).....	5D-27
9.0 Troubleshooting charts	5D-31
Troubleshooting Flow Chart for Controller	5D-31
Troubleshooting Flow Chart for Receiver (Sheet 1 of 2)	5D-32
Troubleshooting Flow Chart for Receiver (Sheet 2 of 2)	5D-33
Troubleshooting Flow Chart for Transmitter.....	5D-34
Troubleshooting Flow Chart for Synthesizer	5D-35
Troubleshooting Flow Chart for VCO	5D-36

Section 6 *Flex Layout/Schematic Diagrams and Parts Lists*

1.0 RF-Controller Interconnect Flex.....	6-1
1.1 Rev A.....	6-1
1.2 Rev B	6-1

- 2.0 Schematic for RF-Controller Interconnect Flex6-2
- 3.0 Universal Connector Flex.....6-3
 - 3.1 GP328 Plus.....6-3
 - 3.2 GP338 Plus/GP338 XLS.....6-4
- 4.0 Schematic for Universal Connector Flex6-5
 - 4.1 GP328 Plus.....6-5
 - 4.2 GP338 Plus/GP338 XLS.....6-5
- 5.0 Parts List for Universal Connector Flex.....6-6
 - 5.1 GP328 Plus.....6-6
 - 5.2 GP338 Plus/GP338 XLS.....6-6

Section 1

INTRODUCTION

1.0 Scope of Manual

This manual is intended for use by service technicians familiar with similar types of equipment. It contains service information required for the equipment described and is current as of the printing date. Changes which occur after the printing date may be incorporated by a complete Manual revision or alternatively as additions.

NOTE Before operating or testing these units, please read the Safety Information Section in the front of this manual.

2.0 Warranty and Service Support

Motorola offers long term support for its products. This support includes full exchange and/or repair of the product during the warranty period, and service/repair or spare parts support out of warranty. Any "return for exchange" or "return for repair" by an authorised Motorola Dealer must be accompanied by a Warranty Claim Form. Warranty Claim Forms are obtained by contacting an Authorised Motorola Dealer.

2.1 Warranty Period

The terms and conditions of warranty are defined fully in the Motorola Dealer or Distributor or Reseller contract. These conditions may change from time to time and the following notes are for guidance purposes only.

In instances where the product is covered under a "return for replacement" or "return for repair" warranty, a check of the product should be performed prior to shipping the unit back to Motorola. This is to ensure that the product has been correctly programmed or has not been subjected to damage outside the terms of the warranty.

Prior to shipping any radio back to the appropriate Motorola warranty depot, please contact Customer Services. All returns must be accompanied by a Warranty Claim Form, available from your Customer Services representative. Products should be shipped back in the original packaging, or correctly packaged to ensure no damage occurs in transit.

2.2 After Warranty Period

After the Warranty period, Motorola continues to support its products in two ways.

1. Motorola's Accessories and Aftermarket Division (AAD) offers a repair service to both end users and dealers at competitive prices.
2. AAD supplies individual parts and modules that can be purchased by dealers who are technically capable of performing fault analysis and repair.

2.3 Piece Parts

Some replacement parts, spare parts, and/or product information can be ordered directly. If a complete Motorola part number is assigned to the part, it is available from Motorola's Accessories and Aftermarket Division (AAD). If no part number is assigned, the part is not normally available from Motorola. If the part number is appended with an asterisk, the part is serviceable by Motorola Depot only. If a parts list is not included, this generally means that no user-serviceable parts are available for that kit or assembly.

All orders for parts/information should include the complete Motorola identification number. All part orders should be directed to your local AAD office. Please refer to your latest price pages.

2.4 Technical Support

Technical support is available to assist the dealer/distributor in resolving any malfunction which may be encountered. Initial contact should be by telephone wherever possible. When contacting Motorola Technical Support, be prepared to provide the product model number and the unit's serial number.

2.5 Further Assistance From Motorola

You can also call the CGISS Indirect Business Customer Help Desk number, (604)-6302525 or send an email to customercare.asia@motorola.com.

Section 2

SERVICE AIDS

1.0 Recommended Test Tools

Table 2-1 lists the tools recommended for working on this family of radios. These tools are also available from Motorola.

Table 2-1: Recommended Test Tools

Motorola Part No.	Description	Application
6680387A59 6680387A64 6680387A65 0180382A31	Extractor, 2-contact Heat controller with safety stand or Safety stand only Portable desoldering unit	Removal of discrete surface-mounted devices
6680375A74 0180386A81 0180386A78	0.025 replacement tip, 5/pk Miniature digital readout soldering station (incl. 1/64" micropoint tip) Illuminated magnifying glass with lens attachment.	For 0180382A31 portable desoldering unit.
0180386A82 6684253C72 6680384A98 1010041A86 1080370B43	Anti-static grounding kit Straight prober Brush Solder (RMA type), 63/37, 0.020" diameter 1 lb. spool RMA liquid flux	Used during all radio assembly and disassembly procedures
R-1070A or R-1319A	Shields and surface-mounted component - IC removal/rework station (order all heat-focus heads separately) Shields and surface-mounted component - IC removal/rework station SMD10000 M.A.P.E.	Removal and assembly of surface-mounted integrated circuits and shields Removal and assembly of surface-mounted integrated circuits and shields

THIS PAGE INTENTIONALLY LEFT BLANK

Section 3

POWER UP SELF-TEST

1.0 Error Codes

Turning on the radio using the ON/OFF volume control starts a self-test routine which checks the RAM, ROM checksum, EEPROM hardware and EEPROM checksum. If these checks are successfully completed, the radio will generate the Self-Test Pass Tone. Radio emits only “bonk” (300 Hz) tone if it fails the self-test.

Error Code	Explanation	Corrective Action
“RAM TST ERROR”	RAM Test Failure	Retest radio by turning it off and turning it on again. If message reoccurs, replace RAM (U405).
“ROM CS ERROR”	ROM Checksum is wrong.	Reprogram FLASH Memory, then retest. If message reoccurs, replace ROM (U406).
“EEPROM HW ERROR”	Codeplug structure mismatch, non existence of codeplug.	Reprogram codeplug with correct version and retest radio. If message reoccurs, replace EEPROM (U407).
“EEPROM CS ERROR”	Codeplug checksum is wrong.	Reprogram codeplug.
No Display	Display module is not connected properly. Display module is damaged.	Check connection between main board and display module. Replace with new display module.

THIS PAGE INTENTIONALLY LEFT BLANK

Section 4

CONTROLLER INFORMATION

1.0 Overview

This section provides a detailed theory of operation for the radio and its components.

2.0 Radio Power Distribution

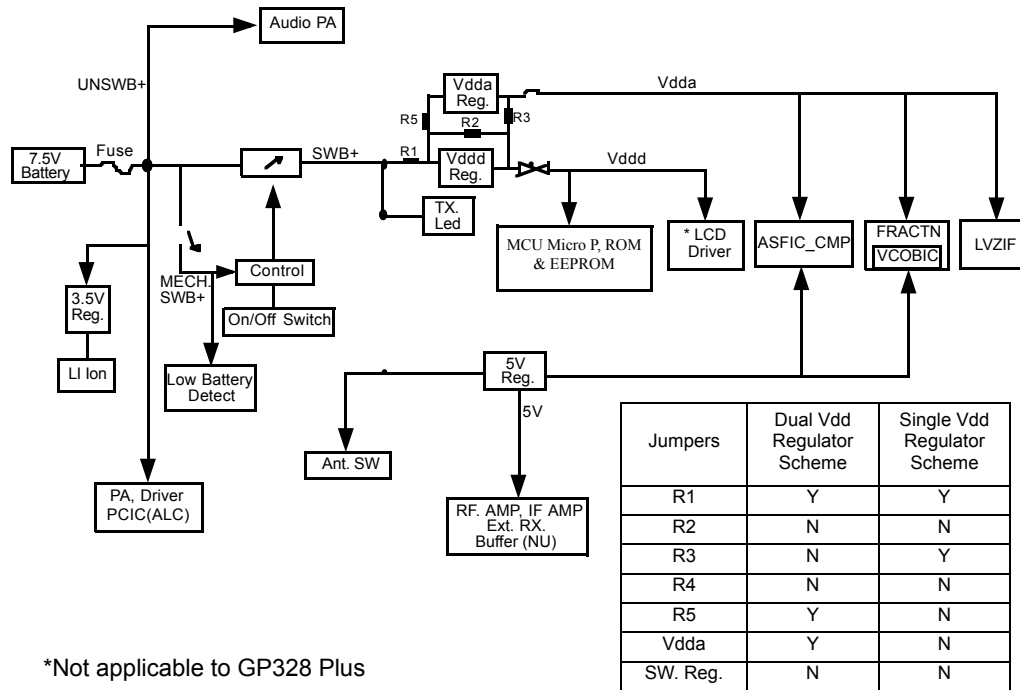

Figure 4-1: DC Power Distribution Block Diagram

Figure 4-1 illustrates the DC distribution throughout the radio board. A 7.5V battery (BATT 7.5V) supplies power directly to the electronic ON/OFF control as UNSWB+. When the radio is turned on, MECH_SWB+ (ON/OFF volume control) will trigger the electronic ON/OFF control (momentary-on path), then SWB+ is distributed as shown in Figure 4-1. Vdda from 3.3V Vdda regulator will then supply the microprocessor. Data is then sent to ASFIC_CMP to turn on GCB4 (DAC). GCB4 will take over the momentary-on path within 12ms. SWB+ will continue to support the whole board until the radio is turned off.

Radio will be turned-off on two conditions;

1. MECH_SWB+ turned off
2. Low battery

When low battery level is detected by the microprocessor through both conditions above, it will store the radio personality data to EEPROM before turning off.

3.0 Controller Board

3.1 General

The controller board is the central interface between the various subsystems of the radio. It is separated into digital and audio architectures. The digital portion consists of a special Motorola microcontroller (HC11FL0). The audio power amplifier (Audio PA) and audio/signalling/filter/companding IC (ASFIC_CMP) form the backbone of the audio/signalling architecture.

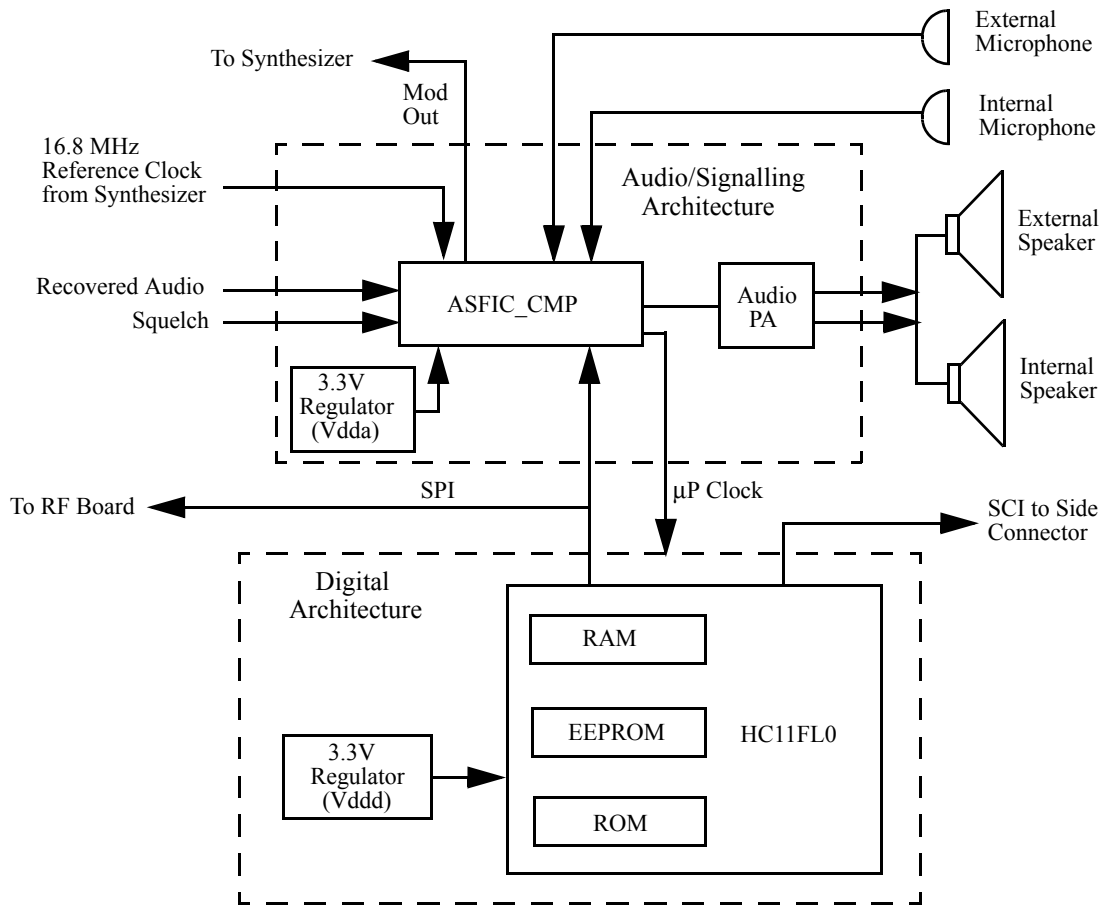

Figure 4-2: Controller Block Diagram

3.2 Digital Architecture

MCU configuration

There is one common MCU architecture for low-tier as well as for the high-tier products. It covers the Conventional and Trunking portables. An open architecture system with the new HC11FL0 as the processor is used. Combinations of different size RAM, ROM and EEPROM are available for various application software.

Real Time Clock (RTC)

This radio supports Real Time Clock (RTC) module for purposes of Message Time Stamping and Time Keeping. The RTC module resides in the micro-processor HC11FL0. It is kept alive by a back-up Lithium Ion battery when the primary battery is removed.

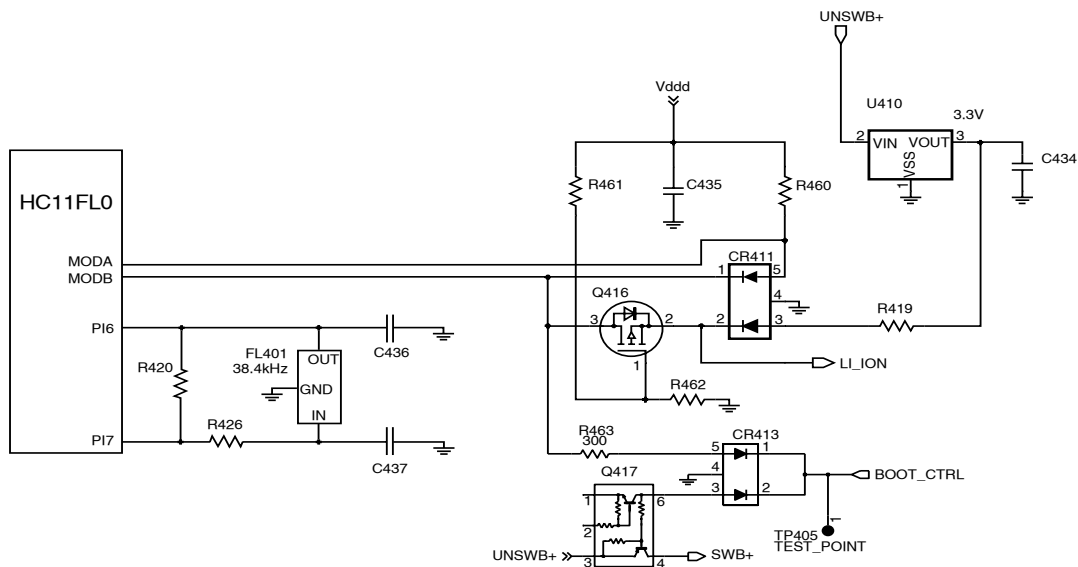

Figure 4-3: RTC Circuit

Circuit Description

The RTC module which resides in the HC11FL0 is powered by the ModB/Vstby pin and PI6/PI7 form the crystal oscillator circuit. Clock frequency of 38.4kHz from a crystal oscillator provides the reference signal. In the processor, the frequency is divided down to 1Hz.

As the RTC module is powered separately from the processor Vdd, the RTC is kept alive through the ModB / Vstby pin when the radio is switched off. A small button Lithium Ion battery continues to feed the RTC when the primary battery is removed.

A MOSFET Q416 switches in the Li (Lithium) Ion supply when Vdd is removed. Q416 also provides isolation from BOOT_CTRL function in the event of radio program flashing. A small 3.3V regulator is used to charge the Li (Lithium) Ion battery.

ModB/Vstby Supply

Under various conditions, the supply to the ModB/Vstby would vary. Table 4-1 shows these conditions and circuits in operation.

Table 4-1: ModB/Vstby Supply Modes

Condition	Circuit Operation
Radio On	Vdd supply voltage via CR411
Radio Off	<ul style="list-style-type: none"> • Vdd turned off • Q416 gate is pulled low by R462 • Q416 is switched on • U410 supplies 3.2V to ModB/Vstby
Primary battery removed	<ul style="list-style-type: none"> • Vdd turned off • Q416 gate is pulled low by R462 • Q416 is switched on • Li Ion battery provides 3.2V to ModB/Vstby
Flash Mode	<ul style="list-style-type: none"> • Boot_Ctrl line pull low • ModA & ModB goes low • Processor in boot-strap mode • Flashing enabled

3.3 Keypad

The LED_EN setting is set by the codeplug. When the value is set to high, the LED will not light up during power up and vice versa.

U602 is a comparator that will compare the voltage when any one of the keypad row or keypad column keys is being pressed. Therefore when a key is being pressed, it will send a message to the microprocessor through the output (KEY_INT) telling it that a key has been pressed. The microprocessor will then sample the Analog to Digital voltages at the keypad row and keypad column and map it with the table so that the key being pressed can be identified. Once the key has been identified, the message that corresponds to the key will show up at the display.

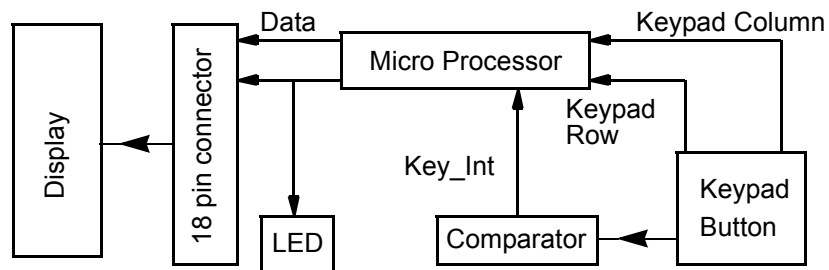

Figure 4-4: Keypad Block Diagram

3.4 Troubleshooting Chart

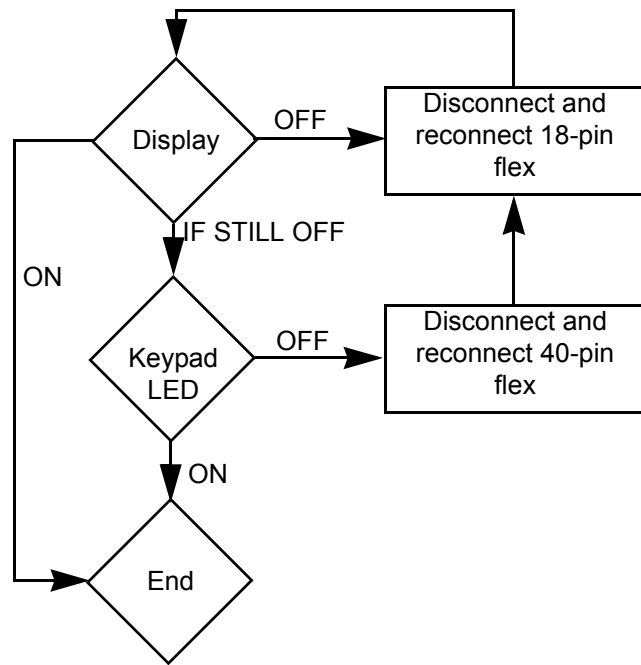
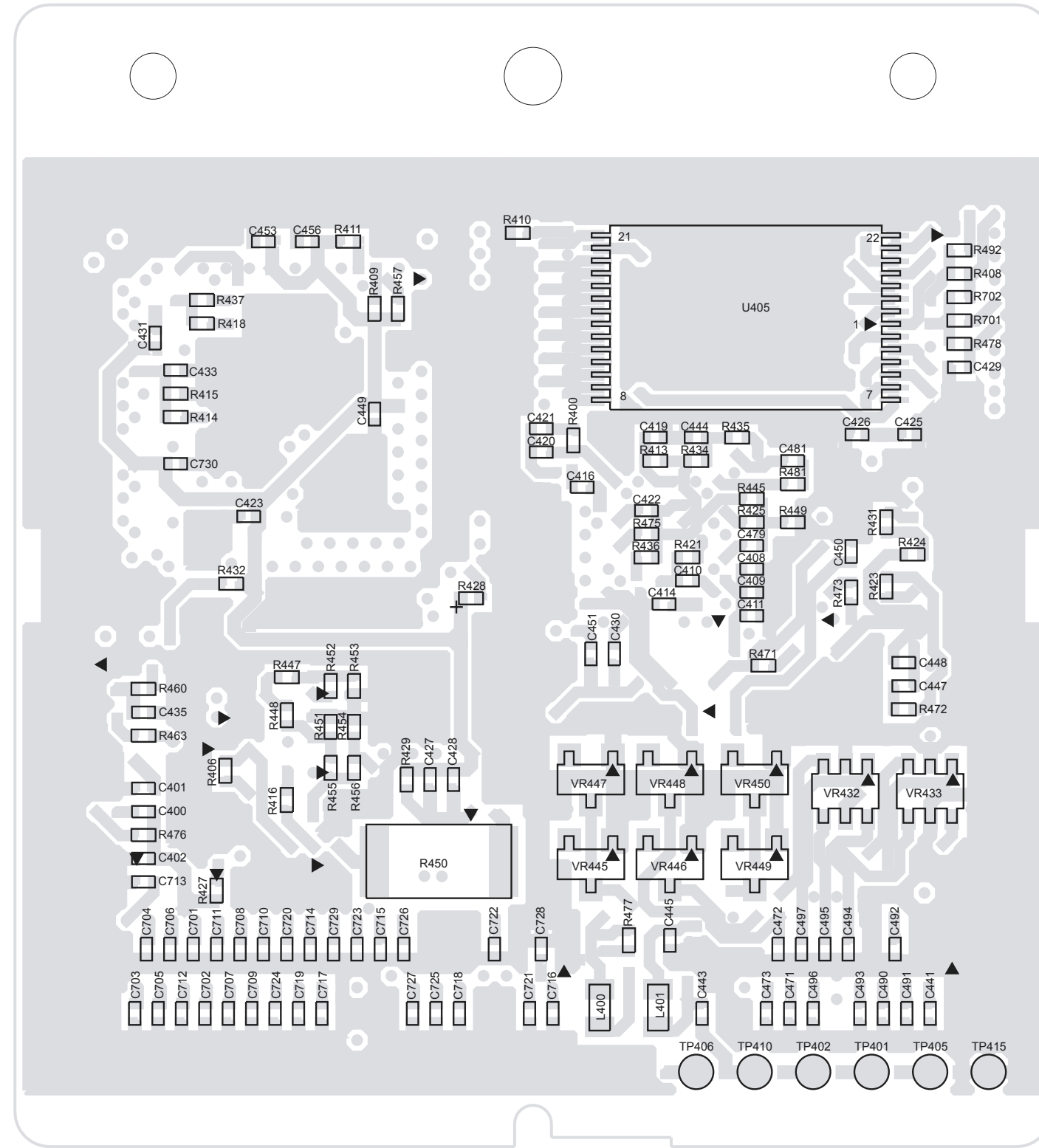

Figure 4-5: Keypad Board Troubleshooting Chart

3.5 Controller Board Diagrams

ZMY0130794-O



Controller Board Top View (PCB No. 8404051G07/G08)

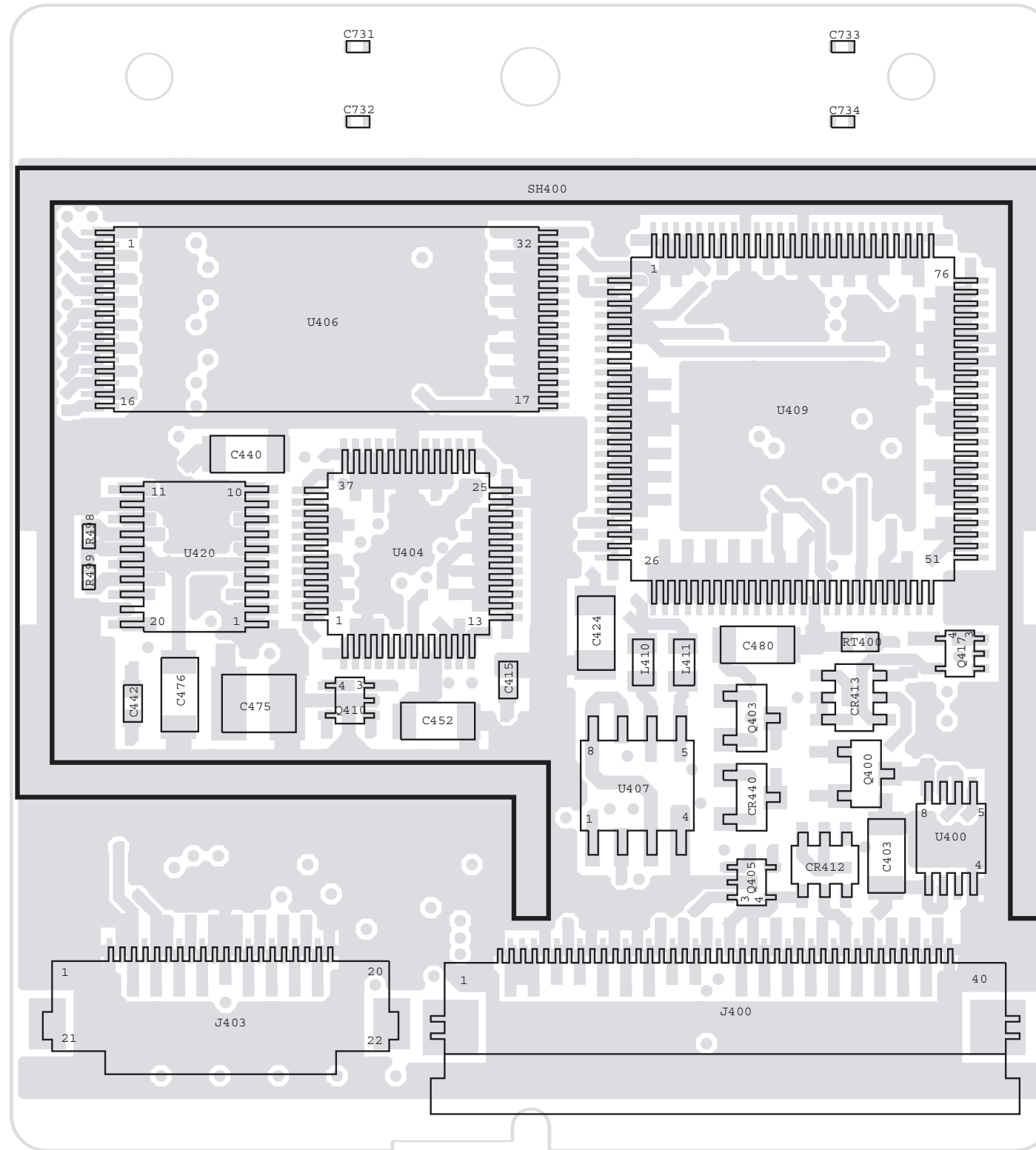

ZMY0130795-O

Controller Board Top View (PCB No. 8404051G07/G08)

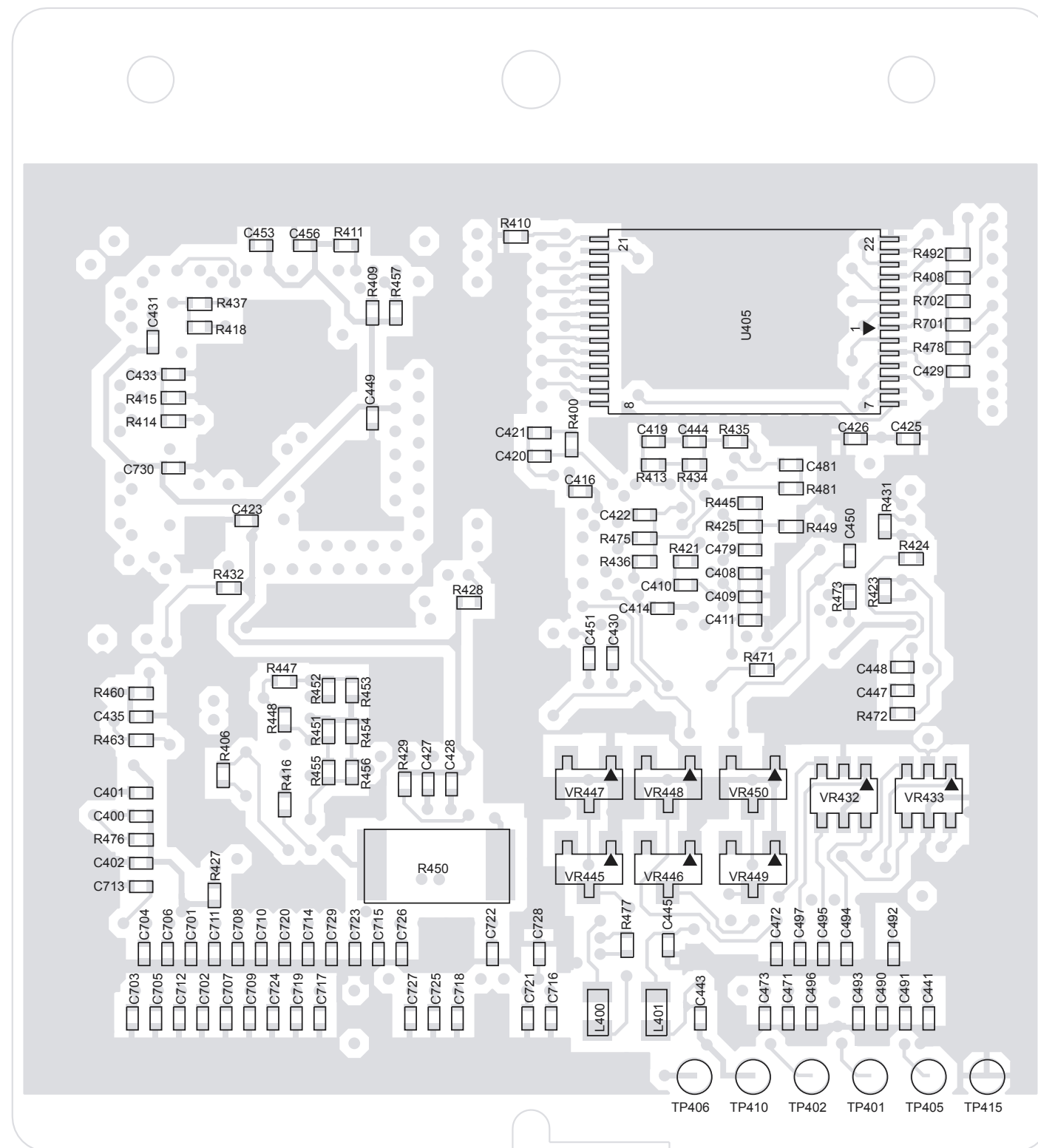

Controller Board Top View (PCB No. 8404051G09)

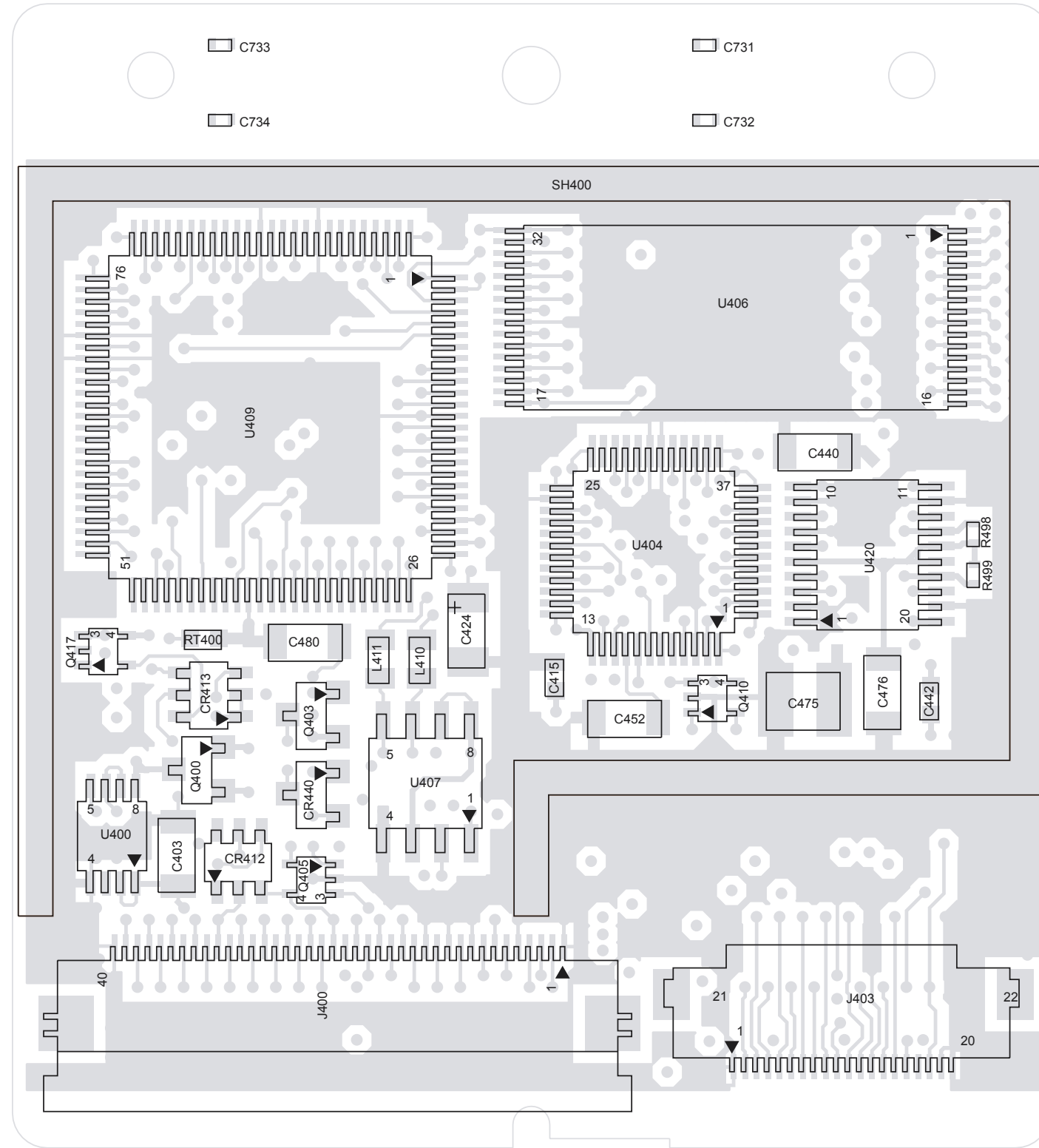

Controller Board Bottom View (PCB No.8404051G09)

3.6 Controller Schematics

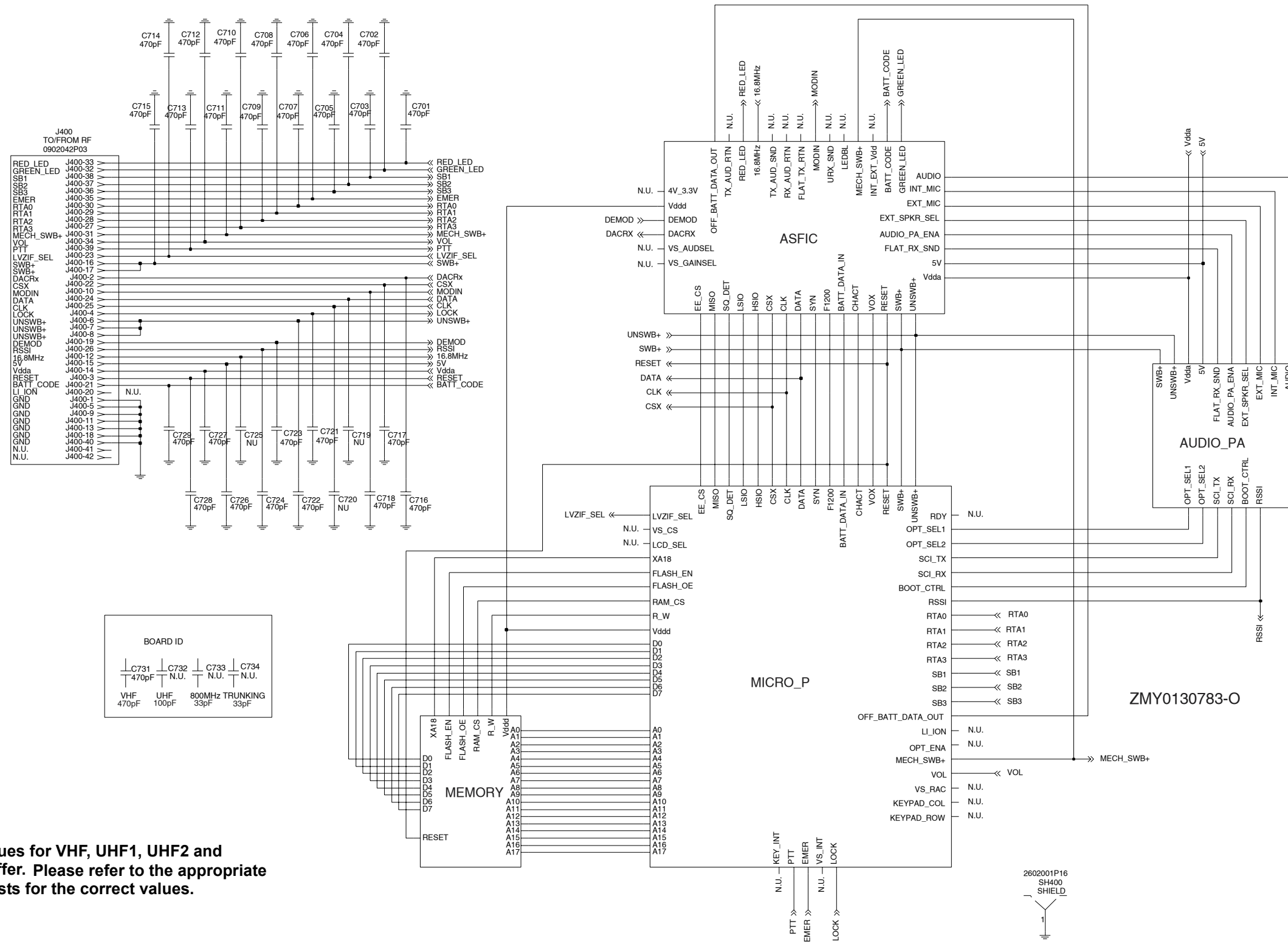

Complete Controller Schematic Diagram

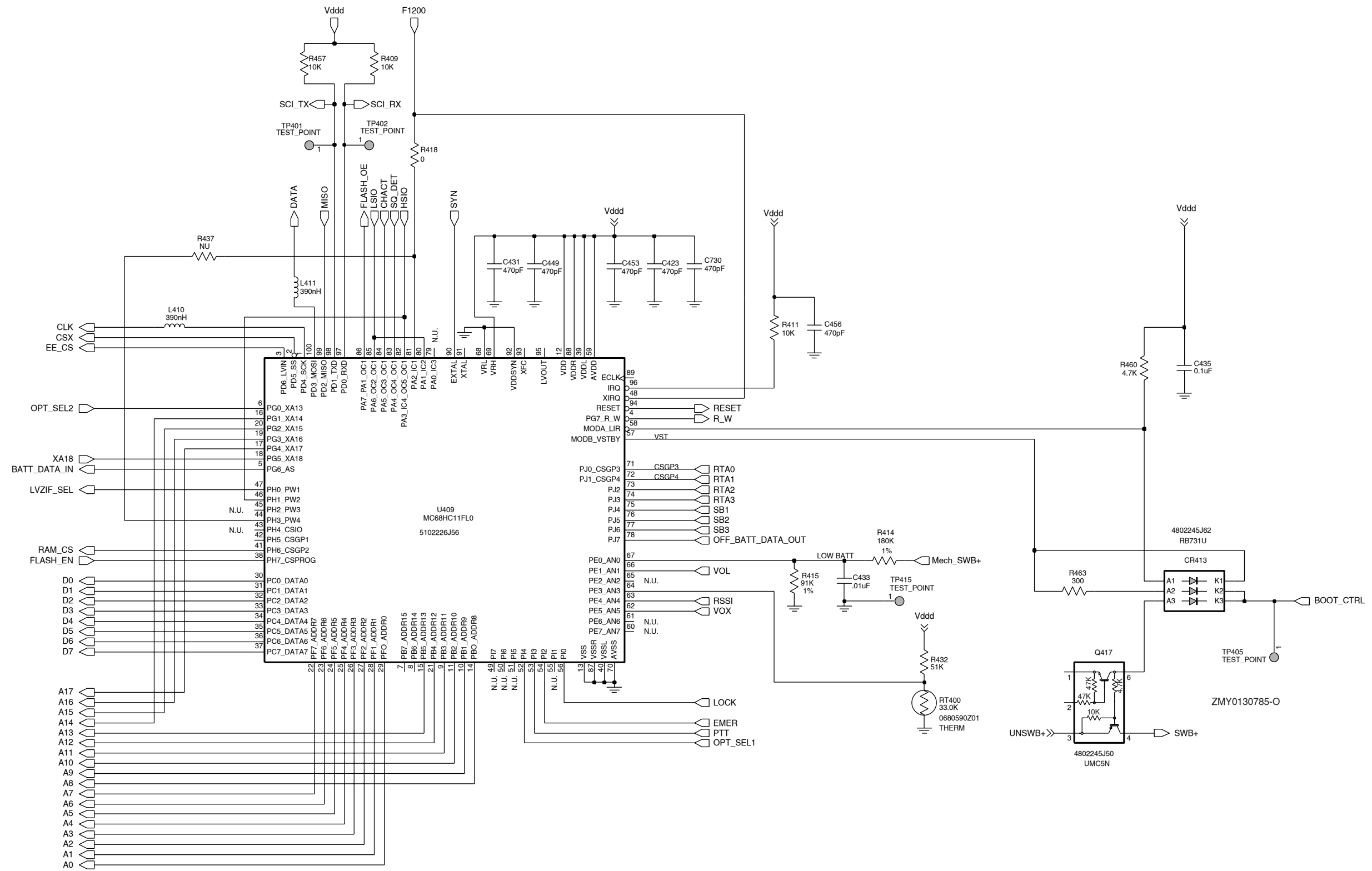

Controller Micro Processor Schematic Diagram

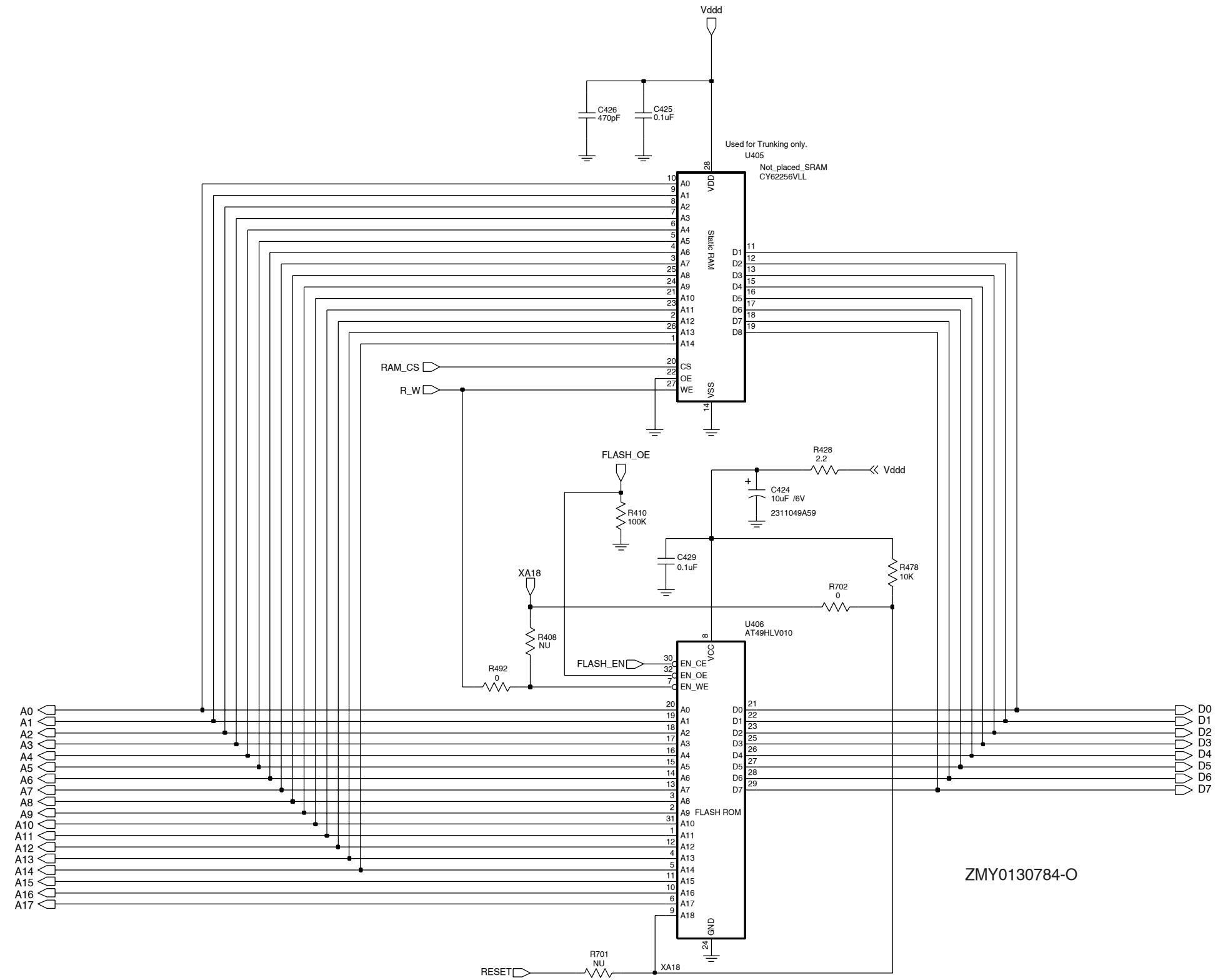

Controller Memory Schematic Diagram

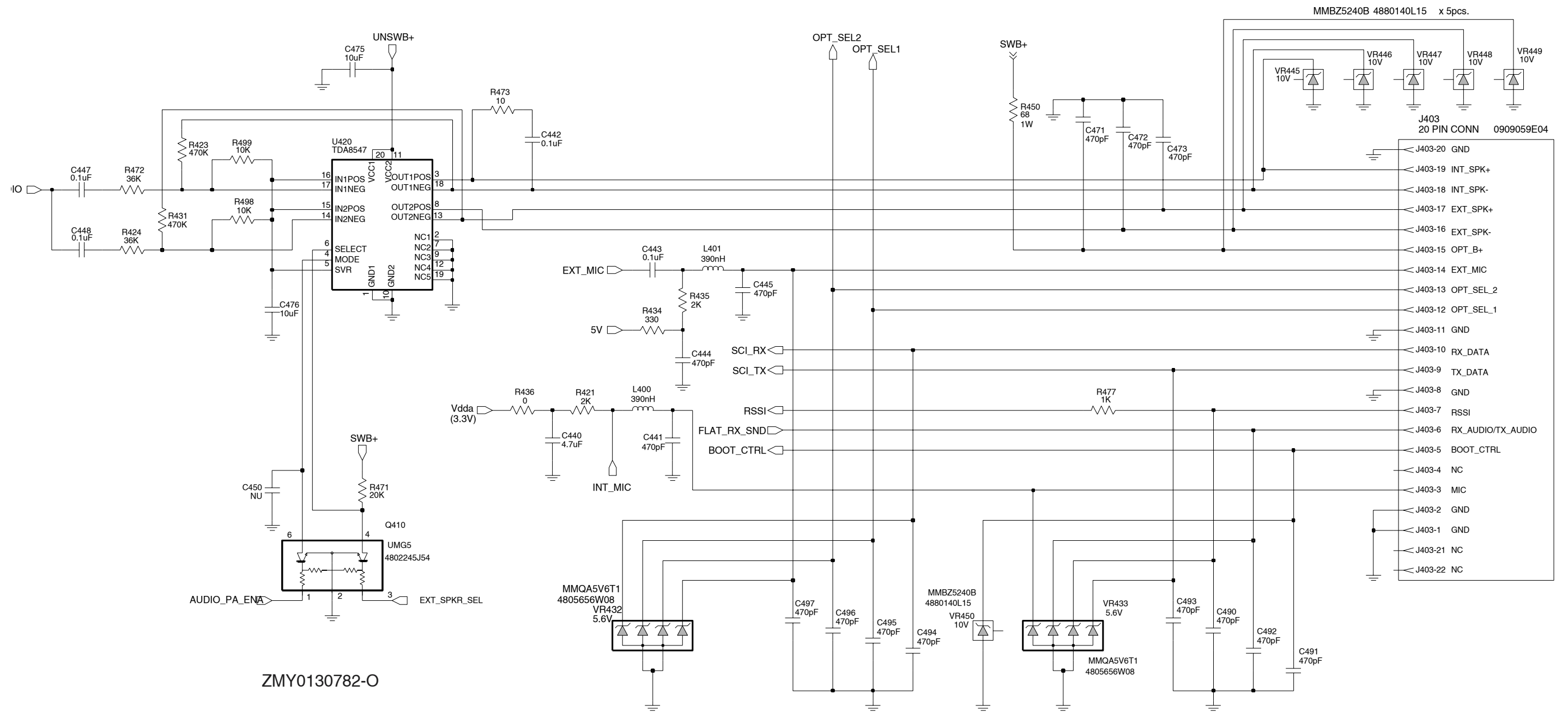

Controller Audio Power Amplifier Schematic Diagram

**Controller Parts List for VHF (for
8404051G07/G08 and 8404051G09)**

Circuit Ref	Motorola Part No.	Description
C400	2113743L41	10000 pF, 10%
C401	2113743M24	100000 pF, +80% / -20%
C402	2113743M24	100000 pF, +80% / -20%
C403	2113928D08	10.0 uF
C408	2113743L09	470 pF, 10%
C409	2113743M24	100000 pF, +80% / -20%
C410	2113928N01	0.1 uF, 10%
C411	2113743M24	100000 pF, +80% / -20%
C414	2113743M24	100000 pF, +80% / -20%
C415	2185895Z01	0.01 uF
C416	2113928N01	0.1 uF, 10%
C419	NOT PLACED	
C420	2113743L41	10000 pF, 10%
C421	2113928N01	0.1 uF, 10%
C422	2113743M24	100000 pF, +80% / -20%
C423	2113743L09	470 pF, 10%
C424	2311049A59	10 uF, 10%
C425	2113743M24	100000 pF, +80% / -20%
C426	2113743L09	470 pF, 10%
C427	2113743L09	470 pF, 10%
C428	2113743M24	100000 pF, +80% / -20%
C429	2113743M24	100000 pF, +80% / -20%
C430	2113928N01	0.1 uF, 10%
C431	2113743L09	470 pF, 10%
C433	2113743L41	10000 pF, 10%
C435	2113743M24	100000 pF, +80% / -20%
C440	2113743G26	4.7 uF, +80% / -20%
C441	2113743L09	470 pF, 10%
C442	2113743E20	0.10 uF, 10%
C443	2113928N01	0.1 uF, 10%
C444	2113743L09	470 pF, 10%
C445	2113743L09	470 pF, 10%
C447	2113928N01	0.1 uF, 10%
C448	2113928N01	0.1 uF, 10%
C449	2113743L09	470 pF, 10%
C450	NOT PLACED	
C451	2113743M08	22000 pF, +80% / -20%
C452	2113743B29	1.00 uF, 10%
C453	2113743L09	470 pF, 10%
C456	2113743L09	470 pF, 10%
C471	2113743L09	470 pF, 10%
C472	2113743L09	470 pF, 10%
C473	2113743L09	470 pF, 10%
C475	2113743H14	10.0 uF, +80% / -20%
C476	2113928D08	10.0 uF
C479	2113928N01	0.1 uF, 10%
C480	2113928D08	10.0 uF

Circuit Ref	Motorola Part No.	Description
C481	2113928N01	0.1 uF, 10%
C490	2113743L09	470 pF, 10%
C491	2113743L09	470 pF, 10%
C492	2113743L09	470 pF, 10%
C493	2113743L09	470 pF, 10%
C494	2113743L09	470 pF, 10%
C495	2113743L09	470 pF, 10%
C496	2113743L09	470 pF, 10%
C497	2113743L09	470 pF, 10%
C701	2113743L09	470 pF, 10%
C702	2113743L09	470 pF, 10%
C703	2113743L09	470 pF, 10%
C704	2113743L09	470 pF, 10%
C705	2113743L09	470 pF, 10%
C706	2113743L09	470 pF, 10%
C707	2113743L09	470 pF, 10%
C708	2113743L09	470 pF, 10%
C709	2113743L09	470 pF, 10%
C710	2113743L09	470 pF, 10%
C711	2113743L09	470 pF, 10%
C712	2113743L09	470 pF, 10%
C713	2113743L09	470 pF, 10%
C714	2113743L09	470 pF, 10%
C715	2113743L09	470 pF, 10%
C716	2113743L09	470 pF, 10%
C717	2113743L09	470 pF, 10%
C718	2113743L09	470 pF, 10%
C719	NOT PLACED	
C720	NOT PLACED	
C721	2113743L09	470 pF, 10%
C722	2113743L09	470 pF, 10%
C723	2113743L09	470 pF, 10%
C724	2113743L09	470 pF, 10%
C725	NOT PLACED	
C726	2113743L09	470 pF, 10%
C727	2113743L09	470 pF, 10%
C728	2113743L09	470 pF, 10%
C729	2113743L09	470 pF, 10%
C730	2113743L09	470 pF, 10%
C731	2113743L09	470 pF, 10%
C732	NOT PLACED	
C733	NOT PLACED	
C734	NOT PLACED	
CR412	4802245J62	Diode Schottky
CR413	4802245J62	Diode Schottky
CR440	4813833C02	Dual Diode, Common Cathode
J400	0902042P03	40 Pins Connector
J403	0909059E04	20 Pins Connector
L400	2462587Q42	390 nH, 10%
L401	2462587Q42	390 nH, 10%

Circuit Ref	Motorola Part No.	Description
L410	2462587Q42	390 nH, 10%
L411	2462587Q42	390 nH, 10%
Q400	4809579E18	TSTR MOSFET
Q403	4813824A17	XSTR PNP 40V
Q405	4802245J54	Digital Transistor
Q410	4802245J54	Digital Transistor
Q417	4809939C05	Transistor Dual NPN / PNP
R400	0662057N15	47 k, 5%
R406	0662057N20	75 k, 5%
R408	NOT PLACED	
R409	0662057M98	10 k, 5%
R410	0662057N23	100 k, 5%
R411	0662057M98	10 k, 5%
R413	0662057M01	0, 5%
R414	0662057V34	180 k, 1%
R415	0662057V26	91 k, 1%
R416	0662057M98	10 k, 5%
R418	0662057M01	0, 5%
R421	0662057M81	2000, 5%
R423	0662057N39	470 k, 5%
R424	0662057N12	36 k, 5%
R425	0662057N10	30 k, 5%
R427	0662057M84	2700, 5%
R428	0662057M10	2.2, 5%
R429	0662057N20	75 k, 5%
R431	0662057N39	470 k, 5%
R432	0662057N16	51 k, 5%
R434	0662057M62	330, 5%
R435	0662057M81	2000, 5%
R436	0662057M01	0, 5%
R437	NOT PLACED	
R445	0662057N08	24 k, 5%
R447	0662057N23	100 k, 5%
R448	0662057M98	10 k, 5%
R449	0662057N08	24 k, 5%
R450	0683962T45	68
R451	0662057N03	15 k, 5%
R452	0662057N23	100 k, 5%
R453	NOT PLACED	
R454	NOT PLACED	
R455	NOT PLACED	
R456	0662057M01	0, 5%
R457	0662057M98	10 k, 5%
R460	0662057M90	4700, 5%
R463	0662057M61	300, 5%
R471	0662057N06	20 k, 5%
R472	0662057N12	36 k, 5%
R473	0662057M26	10, 5%
R475	0662057M01	0, 5%
R476	0662057N08	24 k, 5%
R477	0662057M74	1000, 5%

Circuit Ref	Motorola Part No.	Description
R478	0662057M98	10 k, 5%
R481	0662057N08	24 k, 5%
R492	0662057M01	0, 5%
R498	0662057M98	10 k, 5%
R499	0662057M98	10 k, 5%
R701	NOT PLACED	
R702	0662057M01	0, 5%
RT400	0680590Z01	Thermistor 33k
SH400	2602001P16	Shield, Controller
TP401	NOT PLACED	
TP402	NOT PLACED	
TP405	NOT PLACED	
TP406	NOT PLACED	
TP410	NOT PLACED	
TP415	NOT PLACED	
U400	5102463J40	3.3V Regulator
U404	5185130C53	ASFIC CMP
U405	NOT PLACED	
U406	*5102463J60	Flash ROM 512K x 8
U407	*5102463J64	EEPROM 16K x 8
U409	5102226J56	uP HC11FLO
U420	5102463J44	Audio Amplifier
VR432	4805656W08	Quad Zener Diode
VR433	4805656W08	Quad Zener Diode
VR445	4880140L15	10V Zener
VR446	4880140L15	10V Zener
VR447	4880140L15	10V Zener
VR448	4880140L15	10V Zener
VR449	4880140L15	10V Zener
VR450	4880140L15	10V Zener

* Motorola Depot Servicing only

Controller Parts List for UHF 1, UHF 2 and 330MHz (for 8404051G07/G08 and 8404051G09)

Circuit Ref	Motorola Part No.	Description
C400	2113743L41	0.01uF
C400	2113743L41	10000 pF, 10%
C401	2113743M24	100000 pF, +80% / -20%
C402	2113743M24	100000 pF, +80% / -20%
C403	2113928D08	10.0 uF
C408	2113743N50	100 pF, 5%
C409	2113743M24	100000 pF, +80% / -20%
C410	2113928N01	0.1 uF, 10%
C411	2113743M24	100000 pF, +80% / -20%
C414	2113743M24	100000 pF, +80% / -20%
C415	2185895Z01	0.01 uF
C416	2113928N01	0.1 uF, 10%
C419	NOT PLACED	
C420	2113743L41	10000 pF, 10%
C421	2113928N01	0.1 uF, 10%
C422	2113743M24	100000 pF, +80% / -20%
C423	2113743N50	100 pF, 5%
C424	2311049A59	10 uF, 10%
C425	2113743M24	100000 pF, +80% / -20%
C426	2113743N50	100 pF, 5%
C427	2113743N50	100 pF, 5%
C428	2113743M24	100000 pF, +80% / -20%
C429	2113743M24	100000 pF, +80% / -20%
C430	2113928N01	0.1 uF, 10%
C431	2113743N50	100 pF, 5%
C433	2113743L41	10000 pF, 10%
C435	2113743M24	100000 pF, +80% / -20%
C440	2113743G26	4.7 uF, +80% / -20%
C441	2113743N50	100 pF, 5%
C442	2113743E20	0.10 uF, 10%
C443	2113928N01	0.1 uF, 10%
C444	2113743N50	100 pF, 5%
C445	2113743N50	100 pF, 5%
C447	2113928N01	0.1 uF, 10%
C448	2113928N01	0.1 uF, 10%
C449	2113743N50	100 pF, 5%
C450	NOT PLACED	
C451	2113743M08	22000 pF, +80% / -20%
C452	2113743B29	1.00 uF, 10%
C453	2113743N50	100 pF, 5%
C456	2113743N50	100 pF, 5%
C471	2113743N50	100 pF, 5%
C472	2113743N50	100 pF, 5%
C473	2113743N50	100 pF, 5%
C475	2113743H14	10.0 uF, +80% / -20%
C476	2113928D08	10.0 uF

Circuit Ref	Motorola Part No.	Description
C479	2113928N01	0.1 uF, 10%
C480	2113928D08	10.0 uF
C481	2113928N01	0.1 uF, 10%
C490	2113743N50	100 pF, 5%
C491	2113743N50	100 pF, 5%
C492	2113743N50	100 pF, 5%
C493	2113743N50	100 pF, 5%
C494	2113743N50	100 pF, 5%
C495	2113743N50	100 pF, 5%
C496	2113743N50	100 pF, 5%
C497	2113743N50	100 pF, 5%
C701	2113743N50	100 pF, 5%
C702	2113743N50	100 pF, 5%
C703	2113743N50	100 pF, 5%
C704	2113743N50	100 pF, 5%
C705	2113743N50	100 pF, 5%
C706	2113743N50	100 pF, 5%
C707	2113743N50	100 pF, 5%
C708	2113743N50	100 pF, 5%
C709	2113743N50	100 pF, 5%
C710	2113743N50	100 pF, 5%
C711	2113743N50	100 pF, 5%
C712	2113743N50	100 pF, 5%
C713	2113743N50	100 pF, 5%
C714	2113743N50	100 pF, 5%
C715	2113743N50	100 pF, 5%
C716	2113743N50	100 pF, 5%
C717	2113743N50	100 pF, 5%
C718	2113743N50	100 pF, 5%
C719	NOT PLACED	
C720	NOT PLACED	
C721	2113743N50	100 pF, 5%
C722	2113743N50	100 pF, 5%
C723	2113743N50	100 pF, 5%
C724	2113743N50	100 pF, 5%
C725	NOT PLACED	
C726	2113743N50	100 pF, 5%
C727	2113743N50	100 pF, 5%
C728	2113743N50	100 pF, 5%
C729	2113743N50	100 pF, 5%
C730	2113743N50	100 pF, 5%
C731	NOT PLACED	
C732	2113743N50	100 pF, 5%
C733	NOT PLACED	
C734	NOT PLACED	
CR412	4802245J62	Diode Schottky
CR413	4802245J62	Diode Schottky
CR440	4813833C02	Dual Diode, Common Cathode
J400	0902042P03	40 Pins Connector
J403	0909059E04	20 Pins Connector

Circuit Ref	Motorola Part No.	Description
L400	2462587Q42	390 nH, 10%
L401	2462587Q42	390 nH, 10%
L410	2462587Q42	390 nH, 10%
L411	2462587Q42	390 nH, 10%
Q400	4809579E18	TSTR MOSFET
Q403	4813824A17	XSTR PNP 40V
Q405	4802245J54	Digital Transistor
Q410	4802245J54	Digital Transistor
Q417	4809939C05	Transistor Dual NPN / PNP
R400	0662057N15	47 k, 5%
R406	0662057N20	75 k, 5%
R408	NOT PLACED	
R409	0662057M98	10 k, 5%
R410	0662057N23	100 k, 5%
R411	0662057M98	10 k, 5%
R413	0662057M01	0 , 5%
R414	0662057V34	180 k, 1%
R415	0662057V26	91 k, 1%
R416	0662057M98	10 k, 5%
R418	0662057M01	0 , 5%
R421	0662057M81	2000 , 5%
R423	0662057N39	470 k, 5%
R424	0662057N12	36 k, 5%
R425	0662057N10	30 k, 5%
R427	0662057M84	2700 , 5%
R428	0662057M10	2.2 , 5%
R429	0662057N20	75 k, 5%
R431	0662057N39	470 k, 5%
R432	0662057N16	51 k, 5%
R434	0662057M62	330 , 5%
R435	0662057M81	2000 , 5%
R436	0662057M01	0 , 5%
R437	NOT PLACED	
R445	0662057N08	24 k, 5%
R447	0662057N23	100 k, 5%
R448	0662057M98	10 k, 5%
R449	0662057N08	24 k, 5%
R450	0683962T45	68
R451	0662057N03	15 k, 5%
R452	0662057N23	100 k, 5%
R453	NOT PLACED	
R454	NOT PLACED	
R455	NOT PLACED	
R456	0662057M01	0 , 5%
R457	0662057M98	10 k, 5%
R460	0662057M90	4700 , 5%
R463	0662057M61	300 , 5%
R471	0662057N06	20 k, 5%
R472	0662057N12	36 k, 5%
R473	0662057M26	10 , 5%
R475	0662057M01	0 , 5%

Circuit Ref	Motorola Part No.	Description
R476	0662057N08	24 k, 5%
R477	0662057M74	1000 , 5%
R478	0662057M98	10 k, 5%
R481	0662057N08	24 k, 5%
R492	0662057M01	0 , 5%
R498	0662057M98	10 k, 5%
R499	0662057M98	10 k, 5%
R701	NOT PLACED	
R702	0662057M01	0 , 5%
RT400	0680590Z01	Thermistor 33k
SH400	2602001P16	Shield, Controller
U400	5102463J40	3.3V Regulator
U404	5185130C53	ASFIC CMP
U405	NOT PLACED	
U406	*5102463J60	Flash ROM 512K x 8
U407	*5102463J64	EEPROM 16K x 8
U409	5102226J56	Microprocessor IC
U420	5102463J44	Audio Amplifier
VR432	4805656W08	Quad Zener Diode
VR433	4805656W08	Quad Zener Diode
VR445	4880140L15	10V Zener
VR446	4880140L15	10V Zener
VR447	4880140L15	10V Zener
VR448	4880140L15	10V Zener
VR449	4880140L15	10V Zener
VR450	4880140L15	10V Zener

* Motorola Depot Servicing only

3.7 Controller Board Diagrams

ZMY0130800-O

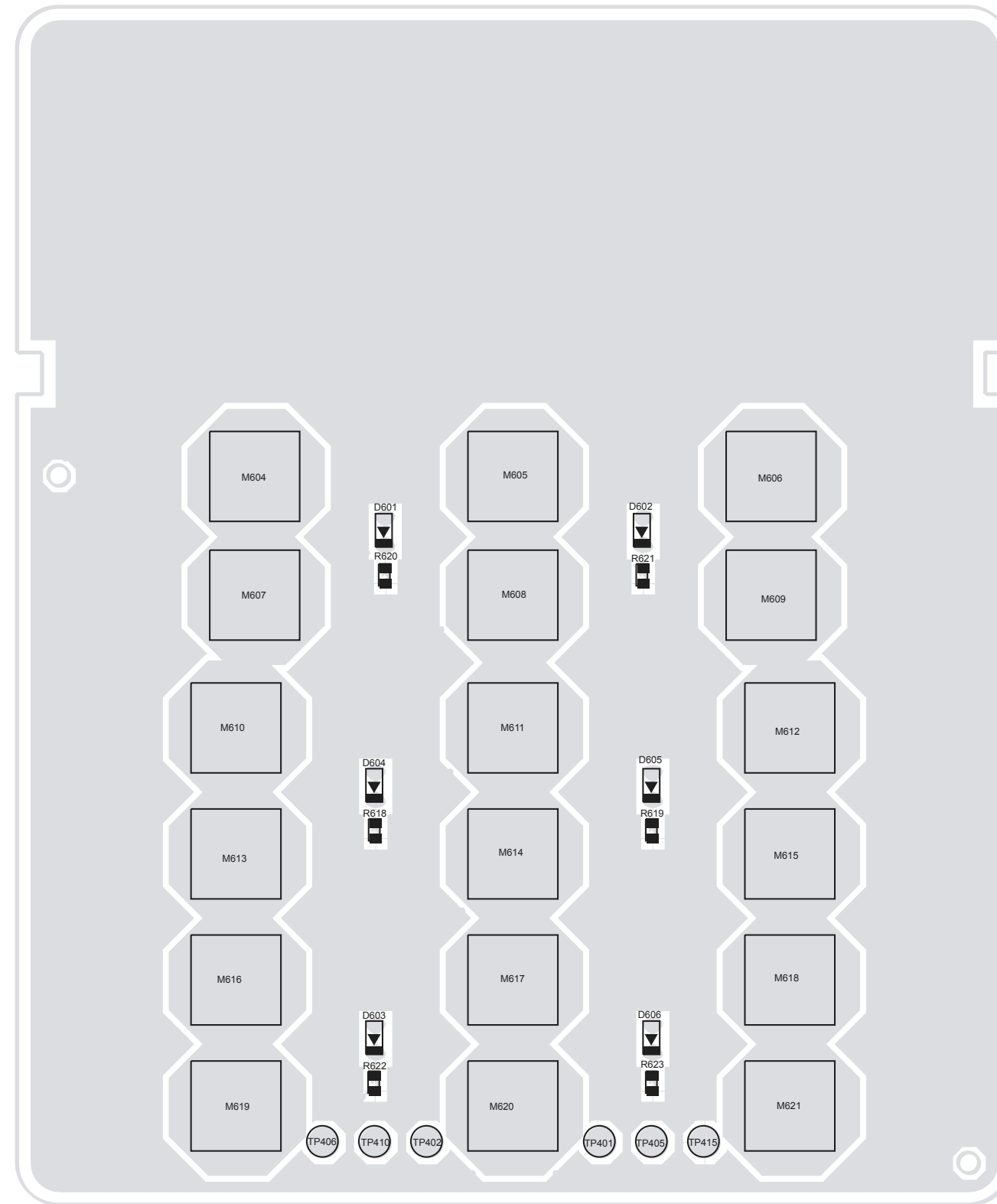

Controller Board Top View (PCB No. 8404056G01)

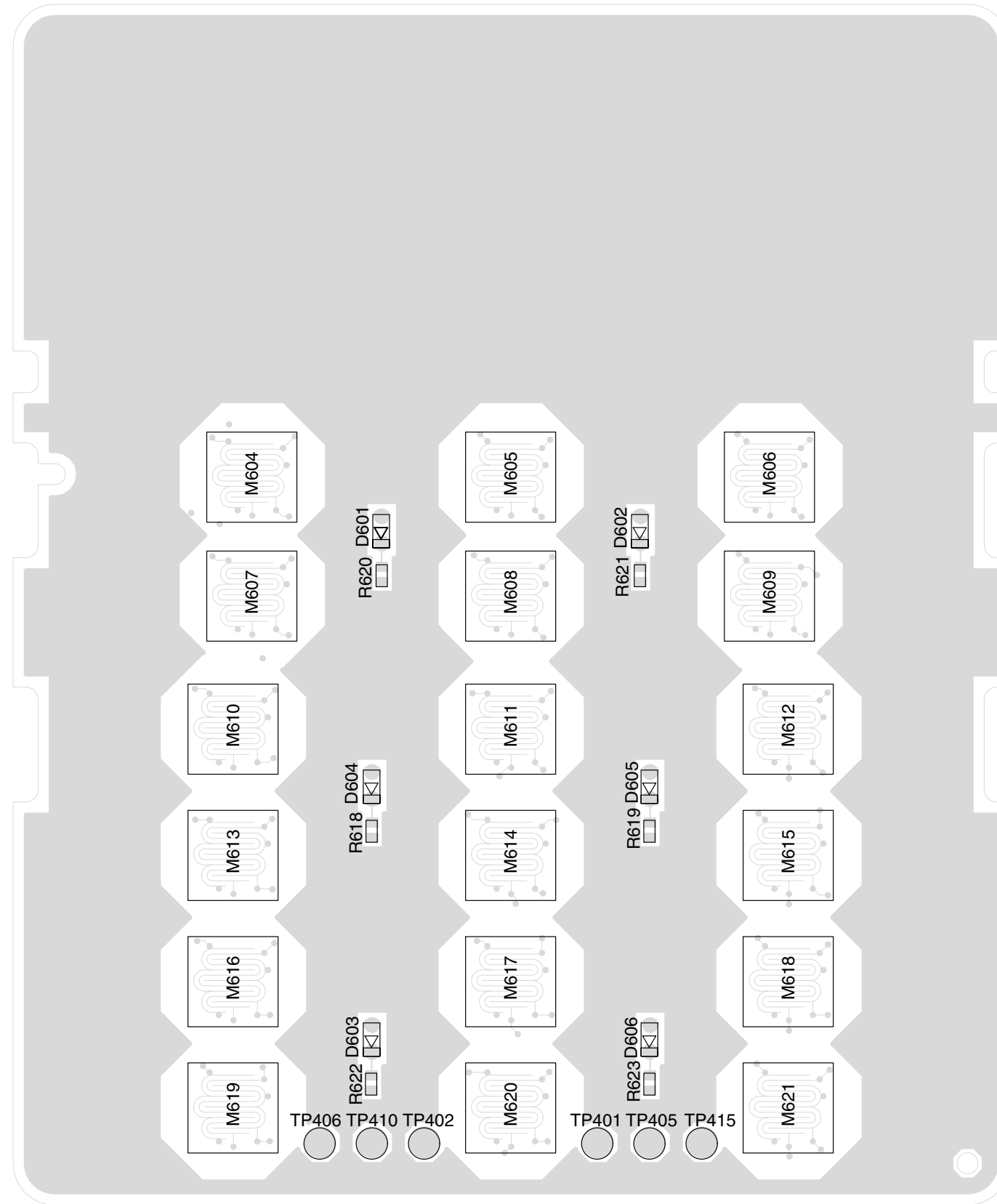

Controller Board Top View (PCB No. 8404056G02)

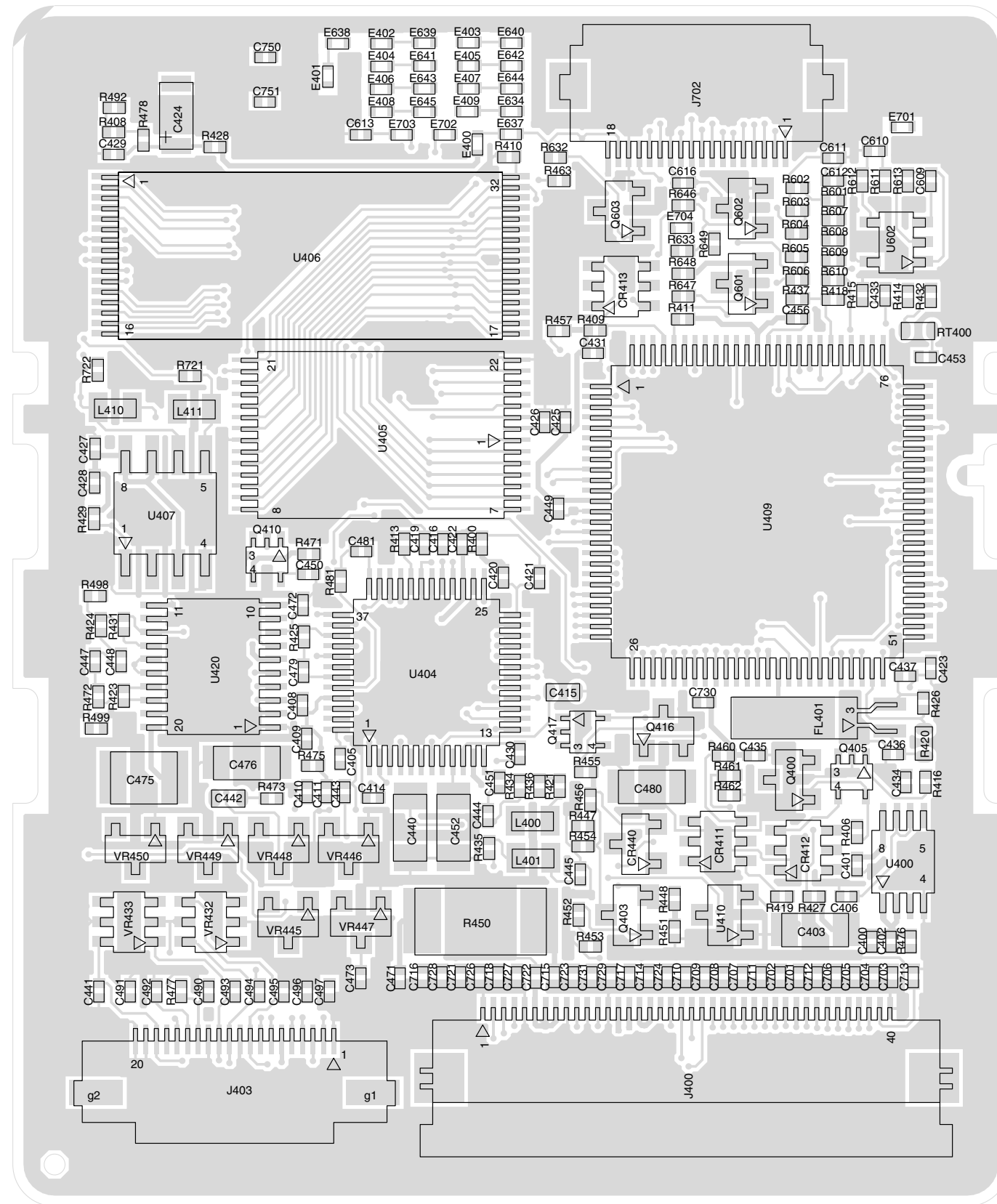

Controller Board Bottom View (PCB No. 8404056G02)

3.8 Controller Schematics

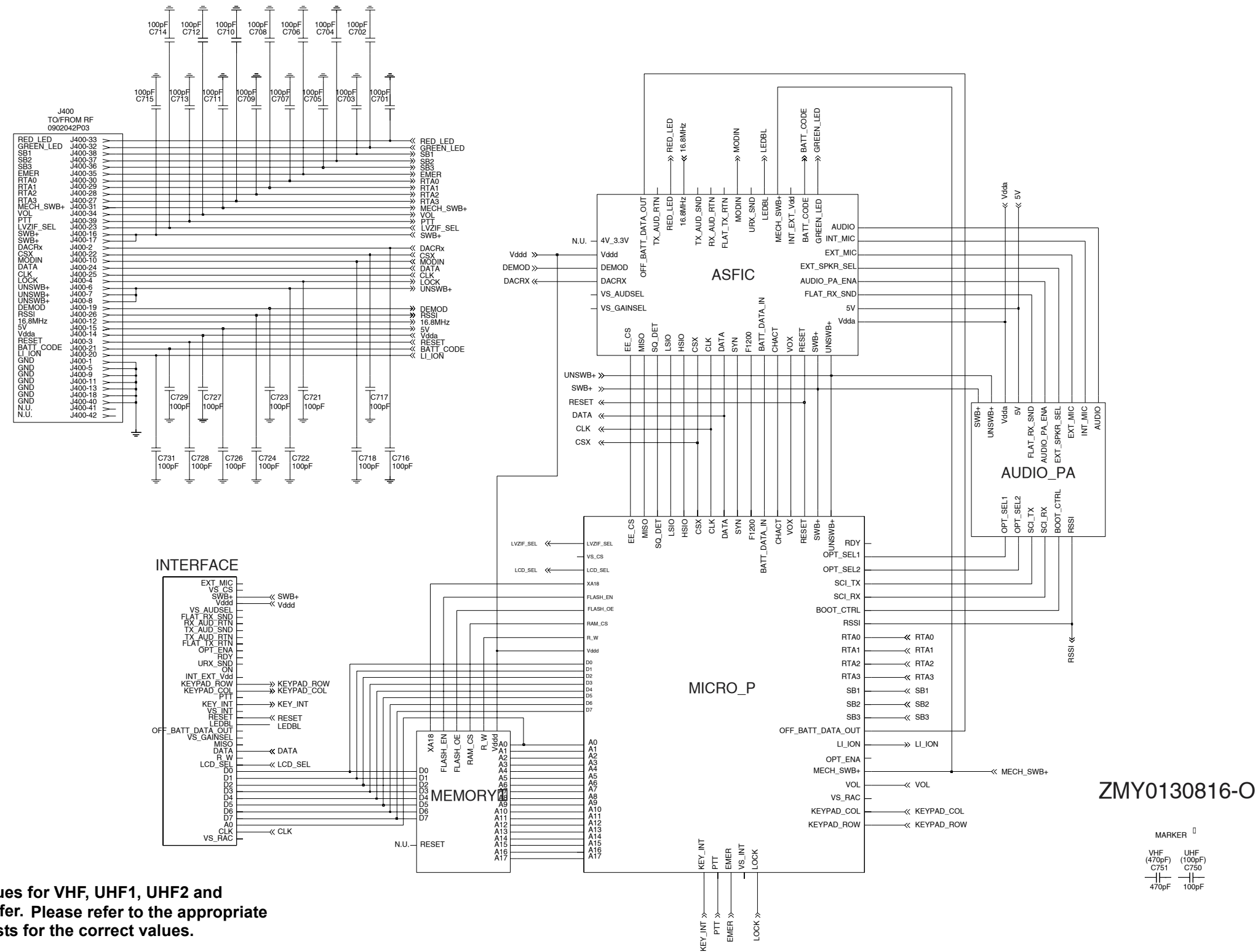

Note: The capacitor values for VHF, UHF1, UHF2 and 330MHz bands differ. Please refer to the appropriate controller parts lists for the correct values.

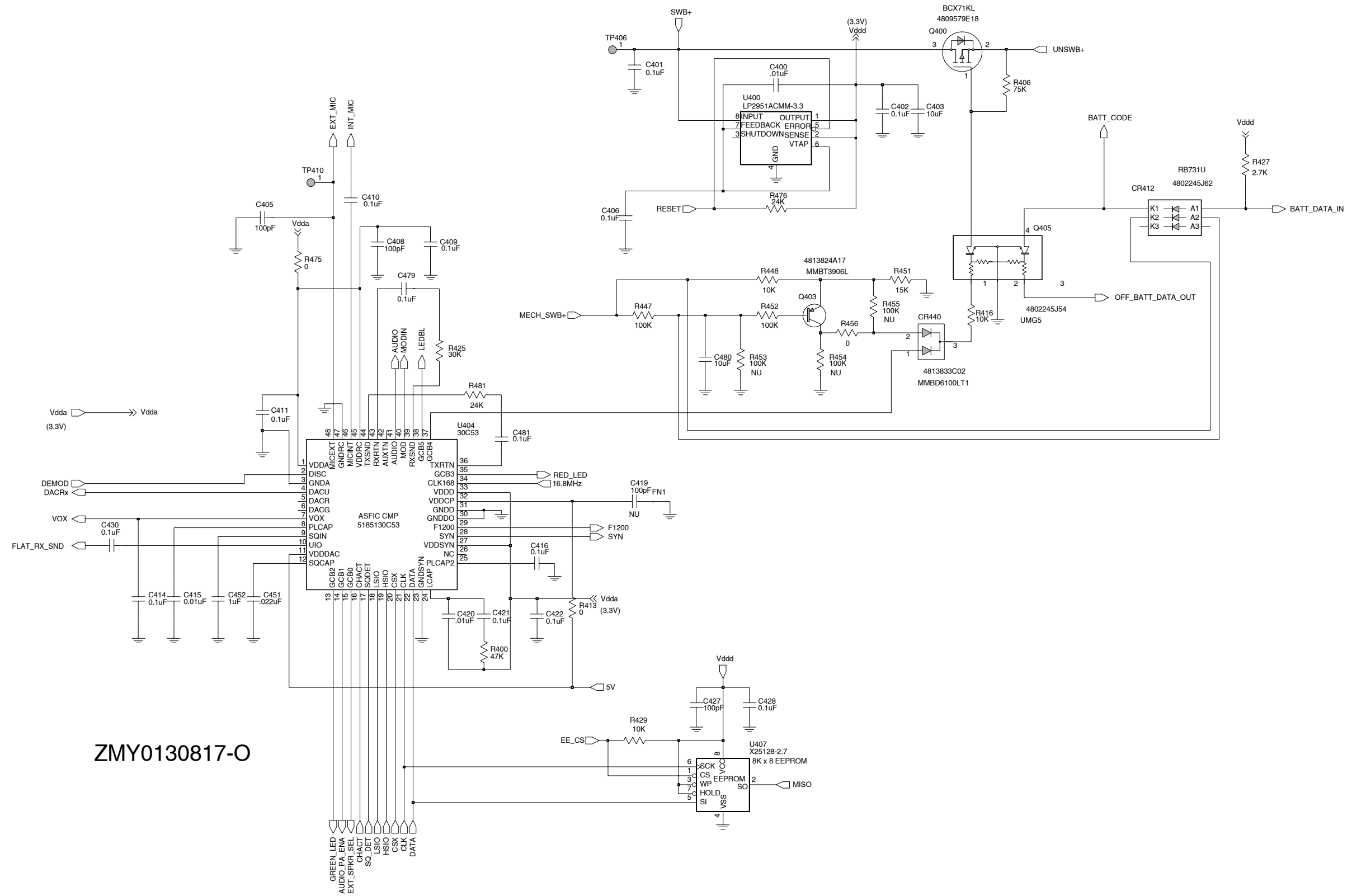

ZMY0130817-O

Controller ASFIC/ON_OFF Schematic Diagram

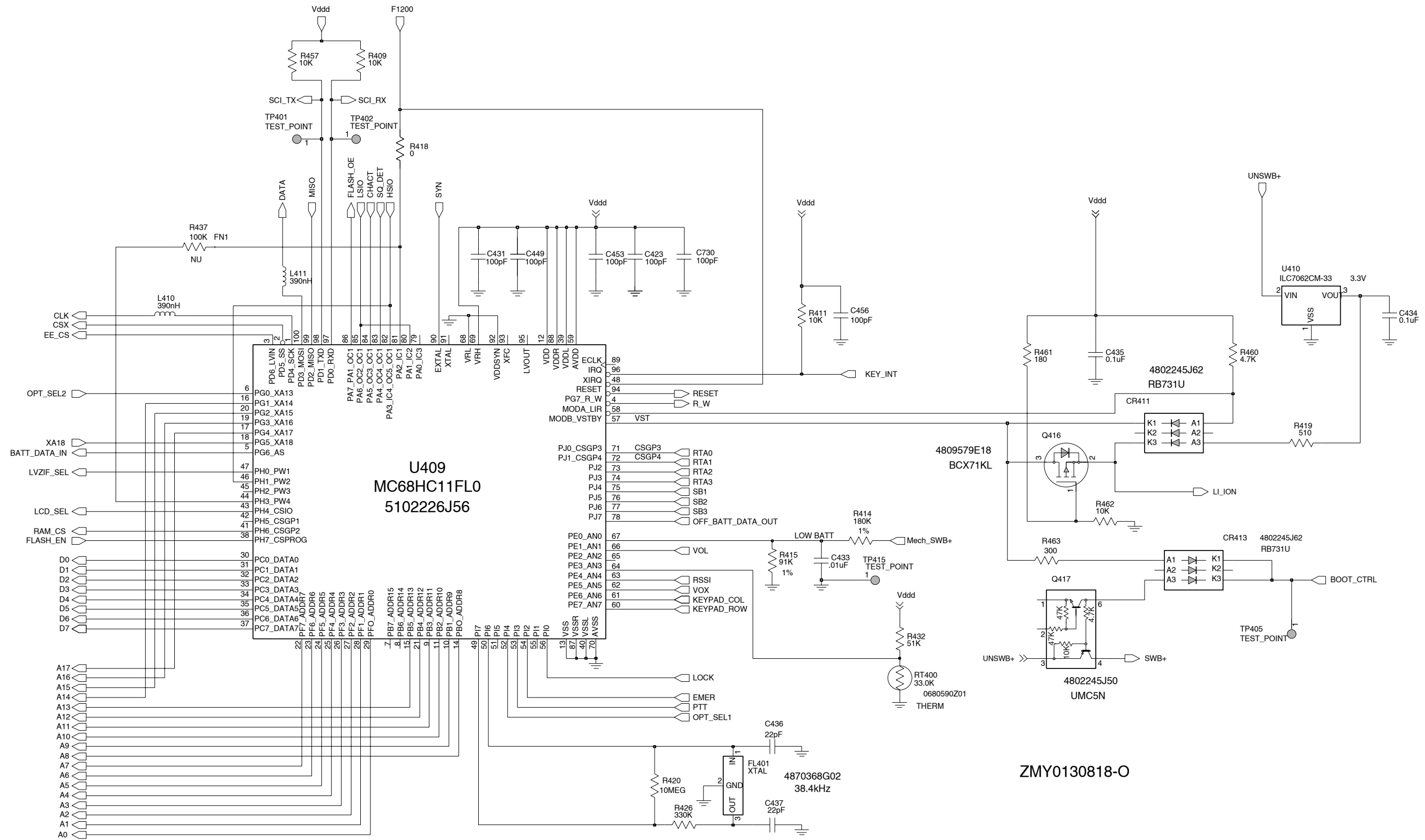

Controller Micro Processor Schematic Diagram

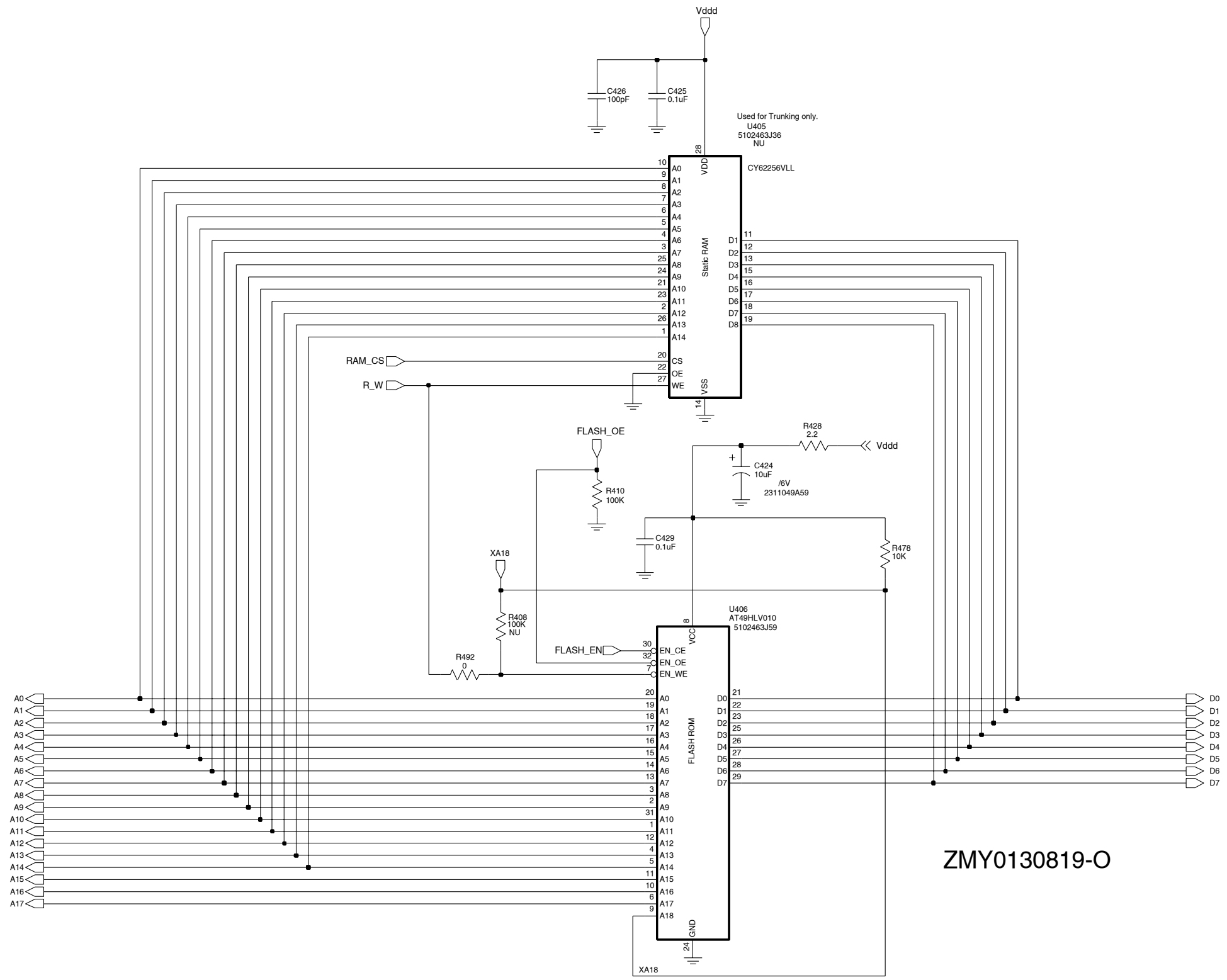

ZMY0130819-O

Controller Memory Schematic Diagram

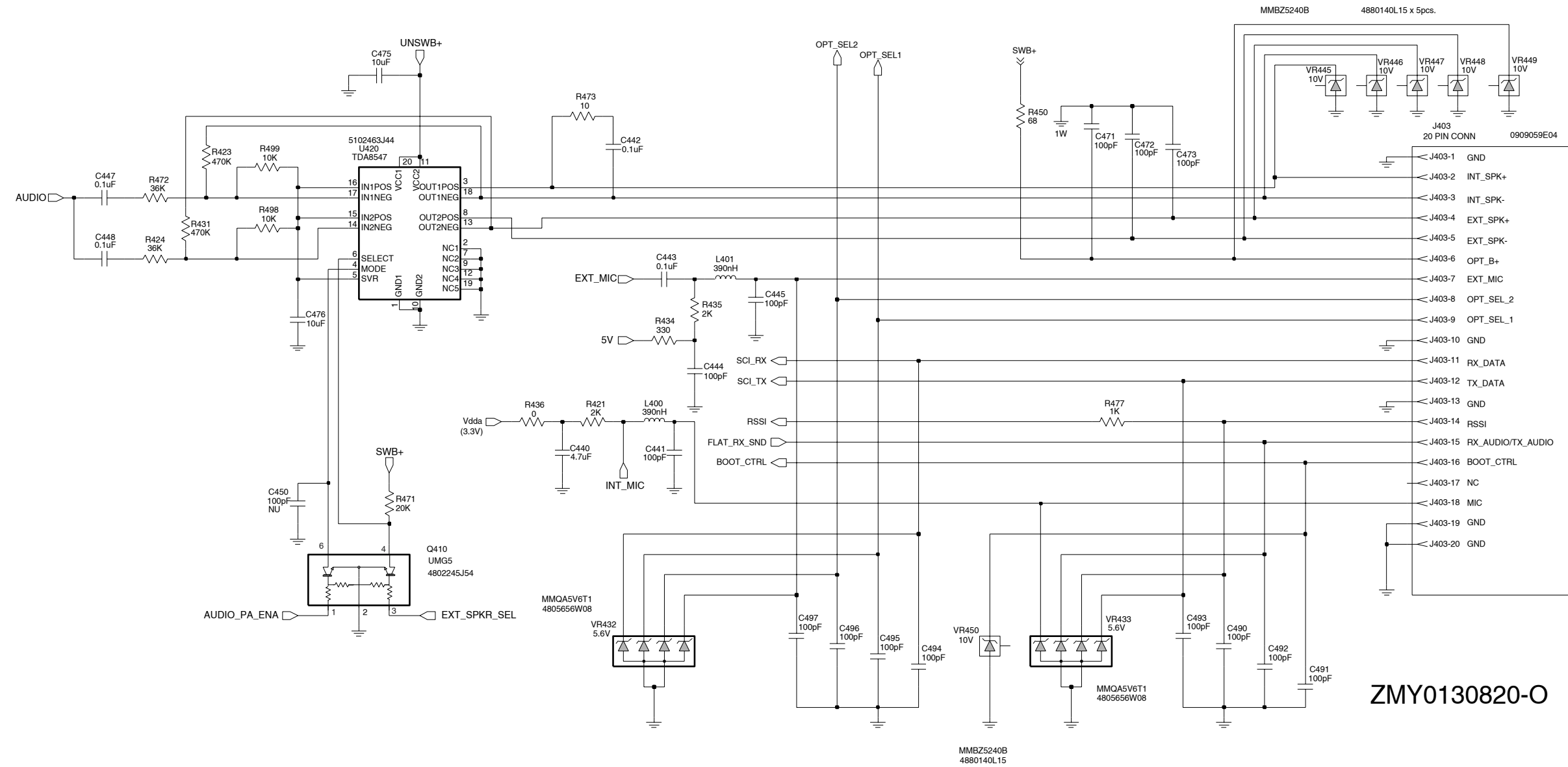

ZMY0130820-O

Controller Audio Power Amplifier Schematic Diagram

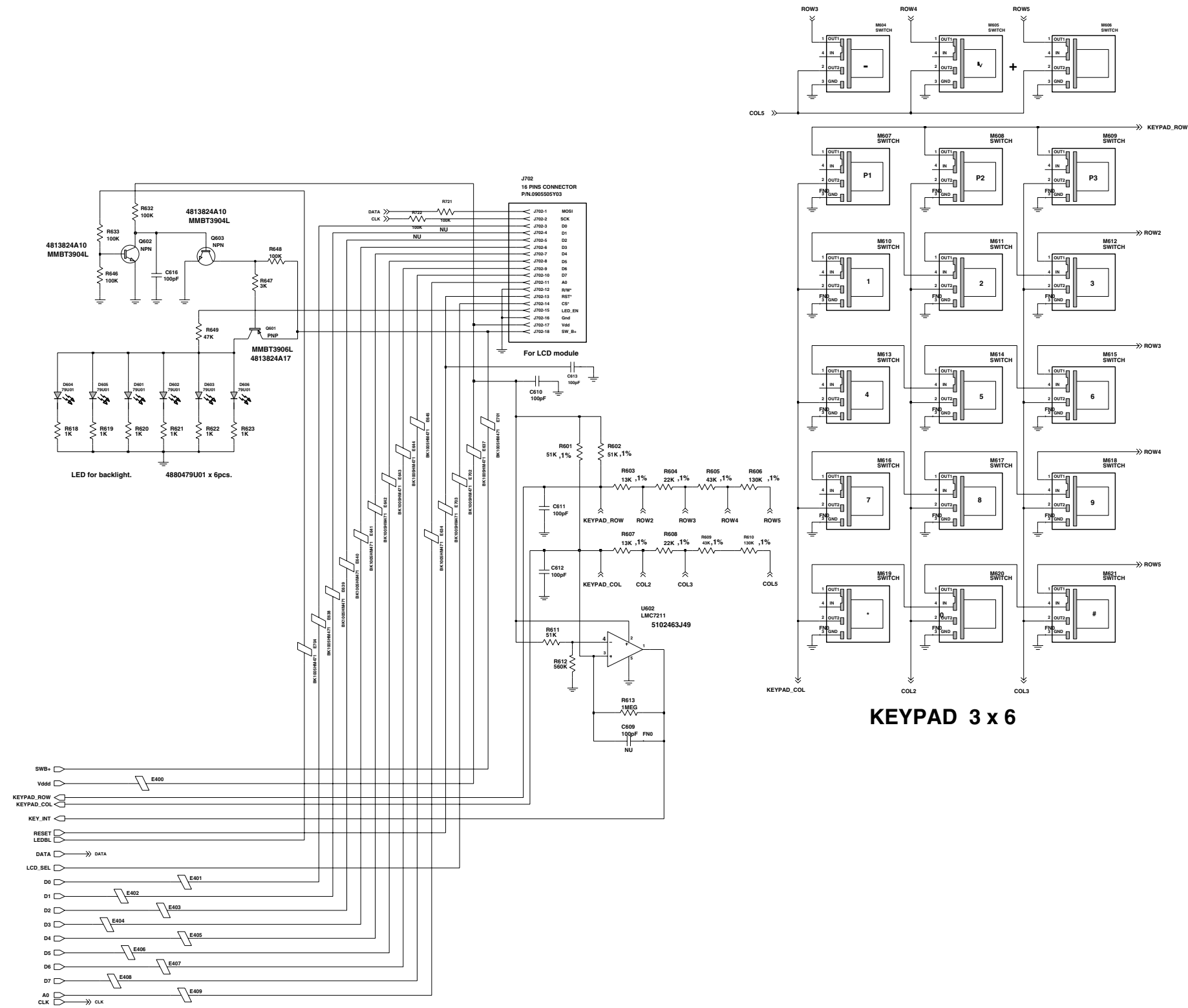

Controller Interface Schematic Diagram (for 8404056G02)

Controller Parts List for VHF (for 8404056G01/G02)

Circuit Ref	Motorola Part No.	Description
C400	2113743L41	10000 pF, 10%
C401	2113743M24	100000 pF, +80% / -20%
C402	2113743M24	100000 pF, +80% / -20%
C403	2113928D08	10.0 uF
C405	2113743L09	470 pF, 10%
C406	2113928N01	0.1uF, 10%
C408	2113743L09	470 pF, 10%
C409	2113743M24	100000 pF, +80% / -20%
C410	2113928N01	0.1uF, 10%
C411	2113743M24	100000 pF, +80% / -20%
C414	2113743M24	100000 pF, +80% / -20%
C415	2185895Z01	0.01 uF
C416	2113928N01	0.1uF, 10%
C419	NOT PLACED	
C420	2113743L41	10000 pF, 10%
C421	2113928N01	0.1uF, 10%
C422	2113743M24	100000 pF, +80% / -20%
C423	2113743L09	470 pF, 10%
C424	2311049A59	10 uF, 10%, 6V
C425	2113743M24	100000 pF, +80% / -20%
C426	2113743L09	470 pF, 10%
C427	2113743L09	470 pF, 10%
C428	2113743M24	100000 pF, +80% / -20%
C429	2113743M24	100000 pF, +80% / -20%
C430	2113928N01	0.1uF, 10%
C431	2113743L09	470 pF, 10%
C433	2113743L41	10000 pF, 10%
C434	2113743M24	100000 pF, +80% / -20%
C435	2113743M24	100000 pF, +80% / -20%
C436	2113743N34	22.0 pF, 5%
C437	2113743N34	22.0 pF, 5%
C440	2113743G26	4.7 uF, +80% / -20%
C441	2113743L09	470 pF, 10%
C442	2113743E20	0.10 uF, 10%
C443	2113928N01	0.1uF, 10%
C444	2113743L09	470 pF, 10%
C445	2113743L09	470 pF, 10%
C447	2113928N01	0.1uF, 10%
C448	2113928N01	0.1uF, 10%
C449	2113743L09	470 pF, 10%
C450	NOT PLACED	
C451	2113743M08	22000 pF, +80% / -20%
C452	2113743B29	1.00 uF, 10%
C453	2113743L09	470 pF, 10%
C456	2113743L09	470 pF, 10%
C471	2113743L09	470 pF, 10%
C472	2113743L09	470 pF, 10%

Circuit Ref	Motorola Part No.	Description
C473	2113743L09	470 pF, 10%
C475	2113743H14	10.0 uF, +80% / -20%
C476	2113928D08	10.0 uF
C479	2113743M24	100000 pF, +80% / -20%
C480	2113928D08	10.0 uF
C481	2113928N01	0.1uF, 10%
C490	2113743L09	470 pF, 10%
C491	2113743L09	470 pF, 10%
C492	2113743L09	470 pF, 10%
C493	2113743L09	470 pF, 10%
C494	2113743L09	470 pF, 10%
C495	2113743L09	470 pF, 10%
C496	2113743L09	470 pF, 10%
C497	2113743L09	470 pF, 10%
C609	NOT PLACED	
C610	2113743L09	470 pF, 10%
C611	2113743L09	470 pF, 10%
C612	2113743L09	470 pF, 10%
C613	2113743L09	470 pF, 10%
C616	2113743L09	470 pF, 10%
C701	2113743L09	470 pF, 10%
C702	2113743L09	470 pF, 10%
C703	2113743L09	470 pF, 10%
C704	2113743L09	470 pF, 10%
C705	2113743L09	470 pF, 10%
C706	2113743L09	470 pF, 10%
C707	2113743L09	470 pF, 10%
C708	2113743L09	470 pF, 10%
C709	2113743L09	470 pF, 10%
C710	2113743L09	470 pF, 10%
C711	2113743L09	470 pF, 10%
C712	2113743L09	470 pF, 10%
C713	2113743L09	470 pF, 10%
C714	2113743L09	470 pF, 10%
C715	2113743L09	470 pF, 10%
C716	2113743L09	470 pF, 10%
C717	2113743L09	470 pF, 10%
C718	2113743L09	470 pF, 10%
C721	2113743L09	470 pF, 10%
C722	2113743L09	470 pF, 10%
C723	2113743L09	470 pF, 10%
C724	2113743L09	470 pF, 10%
C726	2113743L09	470 pF, 10%
C727	2113743L09	470 pF, 10%
C728	2113743L09	470 pF, 10%
C729	2113743L09	470 pF, 10%
C730	2113743L09	470 pF, 10%
C731	2113743L09	470 pF, 10%
C751	2113743L09	470 pF, 10%
CR411	4802245J62	Diode Schottky
CR412	4802245J62	Diode Schottky

Circuit Ref	Motorola Part No.	Description
CR413	4802245J62	Diode Schottky
CR440	4813833C02	Dual Diode, Common Cathode
D601	4880479U01	LED
D602	4880479U01	LED
D603	4880479U01	LED
D604	4880479U01	LED
D605	4880479U01	LED
D606	4880479U01	LED
E400	2480640Z01	Bead
E401	2480640Z01	Bead
E402	2480640Z01	Bead
E403	2480640Z01	Bead
E404	2480640Z01	Bead
E405	2480640Z01	Bead
E406	2480640Z01	Bead
E407	2480640Z01	Bead
E408	2480640Z01	Bead
E409	2480640Z01	Bead
E634	2480640Z01	Bead
E637	2480640Z01	Bead
E638	2480640Z01	Bead
E639	2480640Z01	Bead
E640	2480640Z01	Bead
E641	2480640Z01	Bead
E642	2480640Z01	Bead
E643	2480640Z01	Bead
E644	2480640Z01	Bead
E645	2480640Z01	Bead
E701	2480640Z01	Bead
E702	2480640Z01	Bead
E703	2480640Z01	Bead
E704	2480640Z01	Bead
FL401	4870368G02	Reflowable Clock Osc X'tal
J400	0902042P03	40 Pins Connector
J403	0909059E04	20 Pins Connector
J702	0905505Y03	Conn ZIF Horizontal
L400	2462587Q42	390 nH, 10%
L401	2462587Q42	390 nH, 10%
L410	2462587Q42	390 nH, 10%
L411	2462587Q42	390 nH, 10%
M604	NOT PLACED	
M605	NOT PLACED	
M606	NOT PLACED	
M607	NOT PLACED	
M608	NOT PLACED	
M609	NOT PLACED	
M610	NOT PLACED	
M611	NOT PLACED	
M612	NOT PLACED	
M613	NOT PLACED	

Circuit Ref	Motorola Part No.	Description
M614	NOT PLACED	
M615	NOT PLACED	
M616	NOT PLACED	
M617	NOT PLACED	
M618	NOT PLACED	
M619	NOT PLACED	
M620	NOT PLACED	
M621	NOT PLACED	
Q400	4809579E18	TSTR MOSFET
Q403	4813824A17	XSTR PNP 40V
Q405	4802245J54	Digital Transistor
Q410	4802245J54	Digital Transistor
Q416	4809579E18	TSTR MOSFET
Q417	4809939C05	Transistor Dual NPN / PNP
Q601	4813824A17	XSTR PNP 40V
Q602	4813824A10	Transistor NPN
Q603	4813824A10	Transistor NPN
R400	0662057N15	47 k, 5%
R406	0662057N20	75 k, 5%
R408	NOT PLACED	
R409	0662057M98	10 k, 5%
R410	0662057N23	100 k, 5%
R411	0662057M98	10 k, 5%
R413	0662057M01	0, 5%
R414	0662057V34	180 k, 1%
R415	0662057V26	91 k, 1%
R416	0662057M98	10 k, 5%
R418	0662057M01	0, 5%
R419	0662057M67	510, 5%
R420	0662057B46	10.0 M, 5%
R421	0662057M81	2000, 5%
R423	0662057N39	470 k, 5%
R424	0662057N12	36 k, 5%
R425	0662057N10	30 k, 5%
R426	0662057N35	330 k, 5%
R427	0662057M84	2700, 5%
R428	0662057M10	2.2, 5%
R429	0662057N20	75 k, 5%
R431	0662057N39	470 k, 5%
R432	0662057N16	51 k, 5%
R434	0662057M62	330, 5%
R435	0662057M81	2000, 5%
R436	0662057M01	0, 5%
R437	NOT PLACED	
R447	0662057N23	100 k, 5%
R448	0662057M98	10 k, 5%
R450	0683962T45	68
R451	0662057N03	15 k, 5%
R452	0662057N23	100 k, 5%
R453	NOT PLACED	
R454	NOT PLACED	

Circuit Ref	Motorola Part No.	Description
R455	NOT PLACED	
R456	0662057M01	0, 5%
R457	0662057M98	10 k, 5%
R460	0662057M90	4700, 5%
R461	0662057M56	180, 5%
R462	0662057M98	10 k, 5%
R463	0662057M61	300, 5%
R471	0662057N06	20 k, 5%
R472	0662057N12	36 k, 5%
R473	0662057M26	10, 5%
R475	0662057M01	0, 5%
R476	0662057N08	24 k, 5%
R477	0662057M74	1000, 5%
R478	0662057M98	10 k, 5%
R481	0662057N08	24 k, 5%
R492	0662057M01	0, 5%
R498	0662057M98	10 k, 5%
R499	0662057M98	10 k, 5%
R601	0662057V20	51 k, 1%
R602	0662057V20	51 k, 1%
R603	0662057V05	13 k, 1%
R604	0662057V11	22 k, 1%
R605	0662057V18	43 k, 1%
R606	0662057V30	130 k, 1%
R607	0662057V05	13 k, 1%
R608	0662057V11	22 k, 1%
R609	0662057V18	43 k, 1%
R610	0662057V30	130 k, 1%
R611	0662057N16	51 k, 5%
R612	0662057N41	560 k, 5%
R613	0662057N47	1.0 M, 5%
R618	0662057M74	1000, 5%
R619	0662057M74	1000, 5%
R620	0662057M74	1000, 5%
R621	0662057M74	1000, 5%
R622	0662057M74	1000, 5%
R623	0662057M74	1000, 5%
R632	0662057N23	100 k, 5%
R633	0662057N23	100 k, 5%
R646	0662057N23	100 k, 5%
R647	0662057M85	3000, 5%
R648	0662057N23	100 k, 5%
R649	0662057N15	47 k, 5%
R721	NOT PLACED	
R722	NOT PLACED	
RT400	0680590Z01	Thermistor 33k
TP401	NOT PLACED	
TP402	NOT PLACED	
TP405	NOT PLACED	
TP406	NOT PLACED	
TP410	NOT PLACED	

Circuit Ref	Motorola Part No.	Description
TP415	NOT PLACED	
U400	5102463J40	3.3V Regulator
U404	5185130C53	ASFIC CMP
U405	NOT PLACED	
U406	*5102463J60	Flash ROM 512K x 8
U407	*5102463J64	EEPROM 16K x 8
U409	5102226J56	uP HC11FLO
U410	5102463J57	3.3V Regulator
U420	5102463J44	Audio Amplifier
U602	5102463J49	Comparator CMOS
VR432	4805656W08	Quad Zener Diode
VR433	4805656W08	Quad Zener Diode
VR445	4880140L15	10V Zener
VR446	4880140L15	10V Zener
VR447	4880140L15	10V Zener
VR448	4880140L15	10V Zener
VR449	4880140L15	10V Zener
VR450	4880140L15	10V Zener

Note: E401 through E409 are NOT PLACED in 84D04056G01.

* Motorola Depot Servicing only

**Controller Parts List for UHF 1, UHF 2
and 330MHz (for 8404056G01/G02)**

Circuit Ref	Motorola Part No.	Description
C400	2113743L41	10000 pF, 10%
C401	2113743M24	100000 pF, +80% / -20%
C402	2113743M24	100000 pF, +80% / -20%
C403	2113928D08	10.0 uF
C405	2113743N50	100 pF, 5%
C406	2113928N01	0.1 uF, 10%
C408	2113743N50	100 pF, 5%
C409	2113743M24	100000 pF, +80% / -20%
C410	2113928N01	0.1 uF, 10%
C411	2113743M24	100000 pF, +80% / -20%
C414	2113743M24	100000 pF, +80% / -20%
C415	2185895Z01	0.01 uF
C416	2113928N01	0.1 uF, 10%
C419	NOT PLACED	
C420	2113743L41	10000 pF, 10%
C421	2113928N01	0.1 uF, 10%
C422	2113743M24	100000 pF, +80% / -20%
C423	2113743N50	100 pF, 5%
C424	2311049A59	10 uF, 10%
C425	2113743M24	100000 pF, +80% / -20%
C426	2113743N50	100 pF, 5%
C427	2113743N50	100 pF, 5%
C428	2113743M24	100000 pF, +80% / -20%
C429	2113743M24	100000 pF, +80% / -20%
C430	2113928N01	0.1 uF, 10%
C431	2113743N50	100 pF, 5%
C433	2113743L41	10000 pF, 10%
C434	2113743M24	100000 pF, +80% / -20%
C435	2113743M24	100000 pF, +80% / -20%
C436	2113743N34	22.0 pF, 5%
C437	2113743N34	22.0 pF, 5%
C440	2113743G26	4.7 uF, +80% / -20%
C441	2113743N50	100 pF, 5%
C442	2113743E20	0.10 uF, 10%
C443	2113928N01	0.1 uF, 10%
C444	2113743N50	100 pF, 5%
C445	2113743N50	100 pF, 5%
C447	2113928N01	0.1 uF, 10%
C448	2113928N01	0.1 uF, 10%
C449	2113743N50	100 pF, 5%
C450	NOT PLACED	
C451	2113743M08	22000 pF, +80% / -20%
C452	2113743B29	1.00 uF, 10%
C453	2113743N50	100 pF, 5%
C456	2113743N50	100 pF, 5%
C471	2113743N50	100 pF, 5%
C472	2113743N50	100 pF, 5%

Circuit Ref	Motorola Part No.	Description
C473	2113743N50	100 pF, 5%
C475	2113743H14	10.0 uF, +80% / -20%
C476	2113928D08	10.0 uF
C479	2113743M24	100000 pF, +80% / -20%
C480	2113928D08	10.0 uF
C481	2113928N01	0.1 uF, 10%
C490	2113743N50	100 pF, 5%
C491	2113743N50	100 pF, 5%
C492	2113743N50	100 pF, 5%
C493	2113743N50	100 pF, 5%
C494	2113743N50	100 pF, 5%
C495	2113743N50	100 pF, 5%
C496	2113743N50	100 pF, 5%
C497	2113743N50	100 pF, 5%
C609	NOT PLACED	
C610	2113743N50	100 pF, 5%
C611	2113743N50	100 pF, 5%
C612	2113743N50	100 pF, 5%
C613	2113743N50	100 pF, 5%
C616	2113743N50	100 pF, 5%
C701	2113743N50	100 pF, 5%
C702	2113743N50	100 pF, 5%
C703	2113743N50	100 pF, 5%
C704	2113743N50	100 pF, 5%
C705	2113743N50	100 pF, 5%
C706	2113743N50	100 pF, 5%
C707	2113743N50	100 pF, 5%
C708	2113743N50	100 pF, 5%
C709	2113743N50	100 pF, 5%
C710	2113743N50	100 pF, 5%
C711	2113743N50	100 pF, 5%
C712	2113743N50	100 pF, 5%
C713	2113743N50	100 pF, 5%
C714	2113743N50	100 pF, 5%
C715	2113743N50	100 pF, 5%
C716	2113743N50	100 pF, 5%
C717	2113743N50	100 pF, 5%
C718	2113743N50	100 pF, 5%
C721	2113743N50	100 pF, 5%
C722	2113743N50	100 pF, 5%
C723	2113743N50	100 pF, 5%
C724	2113743N50	100 pF, 5%
C726	2113743N50	100 pF, 5%
C727	2113743N50	100 pF, 5%
C728	2113743N50	100 pF, 5%
C729	2113743N50	100 pF, 5%
C730	2113743N50	100 pF, 5%
C731	2113743N50	100 pF, 5%
C750	2113743N50	100 pF, 5%
CR411	4802245J62	Diode Schottky
CR412	4802245J62	Diode Schottky

Circuit Ref	Motorola Part No.	Description
CR413	4802245J62	Diode Schottky
CR440	4813833C02	Dual Diode, Common Cathode
D601	4880479U01	LED
D602	4880479U01	LED
D603	4880479U01	LED
D604	4880479U01	LED
D605	4880479U01	LED
D606	4880479U01	LED
E400	2480640Z01	Bead
E401	2480640Z01	Bead
E402	2480640Z01	Bead
E403	2480640Z01	Bead
E404	2480640Z01	Bead
E405	2480640Z01	Bead
E406	2480640Z01	Bead
E407	2480640Z01	Bead
E408	2480640Z01	Bead
E409	2480640Z01	Bead
E634	2480640Z01	Bead
E637	2480640Z01	Bead
E638	2480640Z01	Bead
E639	2480640Z01	Bead
E640	2480640Z01	Bead
E641	2480640Z01	Bead
E642	2480640Z01	Bead
E643	2480640Z01	Bead
E644	2480640Z01	Bead
E645	2480640Z01	Bead
E701	2480640Z01	Bead
E702	2480640Z01	Bead
E703	2480640Z01	Bead
E704	2480640Z01	Bead
FL401	4870368G02	Reflowable Clock Osc X'tal
J400	0902042P03	40 Pins Connector
J403	0909059E04	20 Pins Connector
J702	0905505Y03	Conn ZIF Horizontal
L400	2462587Q42	390 nH, 10%
L401	2462587Q42	390 nH, 10%
L410	2462587Q42	390 nH, 10%
L411	2462587Q42	390 nH, 10%
M604	NOT PLACED	
M605	NOT PLACED	
M606	NOT PLACED	
M607	NOT PLACED	
M608	NOT PLACED	
M609	NOT PLACED	
M610	NOT PLACED	
M611	NOT PLACED	
M612	NOT PLACED	
M613	NOT PLACED	

Circuit Ref	Motorola Part No.	Description
M614	NOT PLACED	
M615	NOT PLACED	
M616	NOT PLACED	
M617	NOT PLACED	
M618	NOT PLACED	
M619	NOT PLACED	
M620	NOT PLACED	
M621	NOT PLACED	
Q400	4809579E18	TSTR MOSFET
Q403	4813824A17	XSTR PNP 40V
Q405	4802245J54	Digital Transistor
Q410	4802245J54	Digital Transistor
Q416	4809579E18	TSTR MOSFET
Q417	4809939C05	Transistor Dual NPN / PNP
Q601	4813824A17	XSTR PNP 40V
Q602	4813824A10	Transistor NPN
Q603	4813824A10	Transistor NPN
R400	0662057N15	47 k, 5%
R406	0662057N20	75 k, 5%
R408	NOT PLACED	
R409	0662057M98	10 k, 5%
R410	0662057N23	100 k, 5%
R411	0662057M98	10 k, 5%
R413	0662057M01	0 , 5%
R414	0662057V34	180 k, 1%
R415	0662057V26	91 k, 1%
R416	0662057M98	10 k, 5%
R418	0662057M01	0 , 5%
R419	0662057M67	510 , 5%
R420	0662057B46	10.0 M, 5%
R421	0662057M81	2000 , 5%
R423	0662057N39	470 k, 5%
R424	0662057N12	36 k, 5%
R425	0662057N10	30 k, 5%
R426	0662057N35	330 k, 5%
R427	0662057M84	2700 , 5%
R428	0662057M10	2.2 , 5%
R429	0662057N20	75 k, 5%
R431	0662057N39	470 k, 5%
R432	0662057N16	51 k, 5%
R434	0662057M62	330 , 5%
R435	0662057M81	2000 , 5%
R436	0662057M01	0 , 5%
R437	NOT PLACED	
R447	0662057N23	100 k, 5%
R448	0662057M98	10 k, 5%
R450	0683962T45	68
R451	0662057N03	15 k, 5%
R452	0662057N23	100 k, 5%
R453	NOT PLACED	
R454	NOT PLACED	

Circuit Ref	Motorola Part No.	Description
R455	NOT PLACED	
R456	0662057M01	0 , 5%
R457	0662057M98	10 k, 5%
R460	0662057M90	4700 , 5%
R461	0662057M56	180 , 5%
R462	0662057M98	10 k, 5%
R463	0662057M61	300 , 5%
R471	0662057N06	20 k, 5%
R472	0662057N12	36 k, 5%
R473	0662057M26	10 , 5%
R475	0662057M01	0 , 5%
R476	0662057N08	24 k, 5%
R477	0662057M74	1000 , 5%
R478	0662057M98	10 k, 5%
R481	0662057N08	24 k, 5%
R492	0662057M01	0 , 5%
R498	0662057M98	10 k, 5%
R499	0662057M98	10 k, 5%
R601	0662057V20	51 k, 1%
R602	0662057V20	51 k, 1%
R603	0662057V05	13 k, 1%
R604	0662057V11	22 k, 1%
R605	0662057V18	43 k, 1%
R606	0662057V30	130 k, 1%
R607	0662057V05	13 k, 1%
R608	0662057V11	22 k, 1%
R609	0662057V18	43 k, 1%
R610	0662057V30	130 k, 1%
R611	0662057N16	51 k, 5%
R612	0662057N41	560 k, 5%
R613	0662057N47	1.0 M, 5%
R618	0662057M74	1000 , 5%
R619	0662057M74	1000 , 5%
R620	0662057M74	1000 , 5%
R621	0662057M74	1000 , 5%
R622	0662057M74	1000 , 5%
R623	0662057M74	1000 , 5%
R632	0662057N23	100 k, 5%
R633	0662057N23	100 k, 5%
R646	0662057N23	100 k, 5%
R647	0662057M85	3000 , 5%
R648	0662057N23	100 k, 5%
R649	0662057N15	47 k, 5%
R721	NOT PLACED	
R722	NOT PLACED	
RT400	0680590Z01	Thermistor 33k
TP401	NOT PLACED	
TP402	NOT PLACED	
TP405	NOT PLACED	
TP406	NOT PLACED	
TP410	NOT PLACED	

Circuit Ref	Motorola Part No.	Description
TP415	NOT PLACED	
U400	5102463J40	3.3V Regulator
U404	5185130C53	ASFIC CMP
U405	NOT PLACED	
U406	*5102463J60	Flash ROM 512K x 8
U407	*5102463J64	EEPROM 16K x 8
U409	5102226J56	Microprocessor IC
U410	5102463J57	3.3V Regulator
U420	5102463J44	Audio Amplifier
U602	5102463J49	Comparator CMOS
VR432	4805656W08	Quad Zener Diode
VR433	4805656W08	Quad Zener Diode
VR445	4880140L15	10V Zener
VR446	4880140L15	10V Zener
VR447	4880140L15	10V Zener
VR448	4880140L15	10V Zener
VR449	4880140L15	10V Zener
VR450	4880140L15	10V Zener

Note: E401 through E409 are NOT PLACED in
8404056G01

* Motorola Depot Servicing only

Section 5A

MODEL CHART AND TEST SPECIFICATIONS (136-174 MHZ)

1.0 Model Chart

GP Series, VHF, 136-174 MHz				
Model				Description
AZH38KDC9AA2				GP328 Plus 136-174 MHz 5W 4CH
AZH38KDC9AA3				GP328 Plus 136-174 MHz 5W 16 CH
AZH38KDH9AA6				GP338 Plus 136-174 MHz 5W 128 CH
AZH38KDH9DU6				GP338 XLS 136-174 MHz 5W 160 CH
Item				Description
X			PMUD1892_	GP328 Plus Super Tanapa 136-174 MHz 5W 4CH
	X		PMUD1673_	GP328 Plus Super Tanapa 136-174 MHz 5W 16CH
		X	PMUD1674_	GP338 Plus Super Tanapa 136-174 MHz 5W 128CH
			X PMUD1770_	GP338 XLS Super Tanapa 136-174 MHz 5W 160CH
X			PMUD1893_	GP328 Plus Tanapa 136-174 MHz 5W 4CH
	X		PMUD1677_	GP328 Plus Tanapa 136-174 MHz 5W 16CH
		X	PMUD1678_	GP338 Plus Tanapa 136-174 MHz 5W 128CH
			X PMUD1771_	GP338 XLS Tanapa 136-174 MHz 5W 160CH
X			PMHD4021_	GP328 Plus B/C Kit 136-174 MHz 5W 4CH
	X		JMHD4005_	GP328 Plus B/C Kit 136-174 MHz 5W 16CH
		X	PMHD4006_	GP338 Plus B/C Kit 136-174 MHz 5W 128CH
			X PMHD4014_	GP338 XLS B/C Kit 136-174 MHz 5W 160CH
X			PMHD4020_	GP328 Plus Front Housing Kit 4CH
	X		PMHD4000_	GP328 Plus Front Housing Kit 16CH
		X	PMHD4001_	GP338 Plus Front Housing Kit 128CH
			X PMHD4013_	GP338 XLS Front Housing Kit 160CH
X	X	X	X PMAD4012_	Antenna, 136-155 MHz Stubby
X	X	X	X PMAD4013_	Antenna, 155-174 MHz Stubby
X	X	X	X PMAD4014_	Antenna, 136-155 MHz 14 cm
X	X	X	X PMAD4015_	Antenna, 155-174 MHz 14 cm
X	X	X	X PMAD4023_	Antenna, 150-161 MHz 14 cm
X	X	X	X PMAD4025_	Antenna 150-161 MHz Stubby
X	X		6804022G48	GP328 Plus User Guide
		X	6804112J64	GP338 Plus User Guide
			X 6804114J01	GP338 XLS User Guide

x = Indicates one of each is required.

2.0 Specifications (for GP328 Plus)

General

	VHF	
Frequency:	136-174 MHz	
Channel Capacity:	GP328 Plus : 4/16 Channels	
Power Supply:	7.5 Volts ±20%	
Dimensions with Standard High Capacity Lithium Battery:	101.5mm x 55.5mm x 30.5mm	
Dimensions with Ultra High Capacity Lithium Battery:	101.5mm x 55.5mm x 35.5mm	
Weight: with Standard High Capacity Lithium Battery:	250 g	
Weight: with Ultra High Capacity Lithium Battery:	270 g	
Average Battery Life @ (5-5-90 Duty Cycle)	Low Power	High Power
Standard High Capacity Lithium Battery:	>10 hrs	>7 hrs
Ultra High Capacity Lithium Battery:	>14 hrs	>10 hrs
Sealing:	Meets MIL-STD-810-C,D & E and IPX4	
Shock:	Meets MIL-STD-810-C,D & E and TIA/EIA 603	
Vibration:	Meets MIL-STD-810-C,D & E and TIA/EIA 603	
Dust:	Meets MIL-STD-810-C,D & E and IP5X	
Humidity:	Meets MIL-STD-810-C,D & E and TIA/EIA 603	
FCC ID	AZ489FT3801	

Transmitter

	VHF	
RF Output Li Ion @ 7.5V:	Low 1W	High 5W
Frequency	136-174 MHz	
Channel Spacing	12.5/20/25 kHz	
Freq. Stability (-30°C to +60°C)	0.00025%	
Spurs/Harmonics:	-36 dBm < 1 GHz -30 dBm > 1 GHz	
Audio Response: (from 6 dB/oct. Pre-Emphasis, 300 to 3000Hz)	+1, -3 dB	
Audio Distortion: @ 1000 Hz, 60% Rated Max. Dev.	<5%	
FM Noise:	-40 dB	

Receiver

	VHF 12.5kHz	VHF 20/ 25kHz
Frequency:	136-174MHz	136-174MHz
Sensitivity 12dB EIA SINAD:	0.35 µV	0.35 µV
Adjacent Channel Selectivity ETS	-60 dB	-70 dB
Intermodulation ETS	-65 dB	-65 dB
Freq. Stability (-30°C to +60°C):	0.00025%	0.00025%
Spur Rejection:	-70 dB	-70 dB
Image Rejection:	-70 dB	-70 dB
Audio Output @ <5% Distortion	500 mW	500 mW

All specifications are subject to change without notice.

3.0 Specifications (for GP338 Plus/GP338 XLS)

General

	VHF	
Frequency:	136-174 MHz	
Channel Capacity:	GP338 Plus 128 Channels/GP338 XLS 160 Channels	
Power Supply:	7.5 Volts \pm 20%	
Dimensions with Standard High Capacity Lithium Battery:	101.5mm x 55.5mm x 33.0mm	
	with Ultra High Capacity Lithium Battery: 101.5mm x 55.5mm x 38.0mm	
Weight: with Standard High Capacity Lithium Battery:	265 g	
	with Ultra High Capacity Lithium Battery: 285 g	
Average Battery Life @ (5-5-90 Duty Cycle) Standard High Capacity Lithium Battery: Ultra High Capacity Lithium Battery	Low Power	High Power
	>10 hrs	>7 hrs
	>14 hrs	>10 hrs
Sealing:	Meets MIL-STD-810-C, D & E and IPX4	
Shock:	Meets MIL-STD-810-C, D & E and TIA/EIA 603	
Vibration:	Meets MIL-STD-810-C, D & E and TIA/EIA 603	
Dust:	Meets MIL-STD-810-C, D & E and IP5X	
Humidity:	Meets MIL-STD-810-C, D & E and TIA/EIA 603	
FCC ID	AZ489FT3801	

Transmitter

	VHF	
RF Output Li Ion @ 7.5V:	Low 1W	High 5W
Frequency	136-174 MHz	
Channel Spacing	12.5/20/25 kHz	
Freq. Stability (-30°C to +60°C)	0.00025%	
Spurs/Harmonics:	-36 dBm < 1 GHz -30 dBm > 1 GHz	
Audio Response: (from 6 dB/oct. Pre-Emphasis, 300 to 3000Hz)	+1, -3 dB	
Audio Distortion: @ 1000 Hz, 60% Rated Max. Dev.	<5%	
FM Noise:	-40 dB	

Receiver

	VHF 12.5kHz	VHF 20/ 25kHz
Frequency:	136-174MHz	136-174MHz
Sensitivity 12dB EIA SINAD:	0.35 μ V	0.35 μ V
Adjacent Channel Selectivity ETS	-60 dB	-70 dB
Intermodulation ETS	-65 dB	-65 dB
Freq. Stability (-30°C to +60°C):	0.00025%	0.00025%
Spur Rejection:	-70 dB	-70 dB
Image Rejection:	-70 dB	-70 dB
Audio Output @ <5% Distortion	500 mW	500 mW

All specifications are subject to change without notice.

4.0 Transmitter

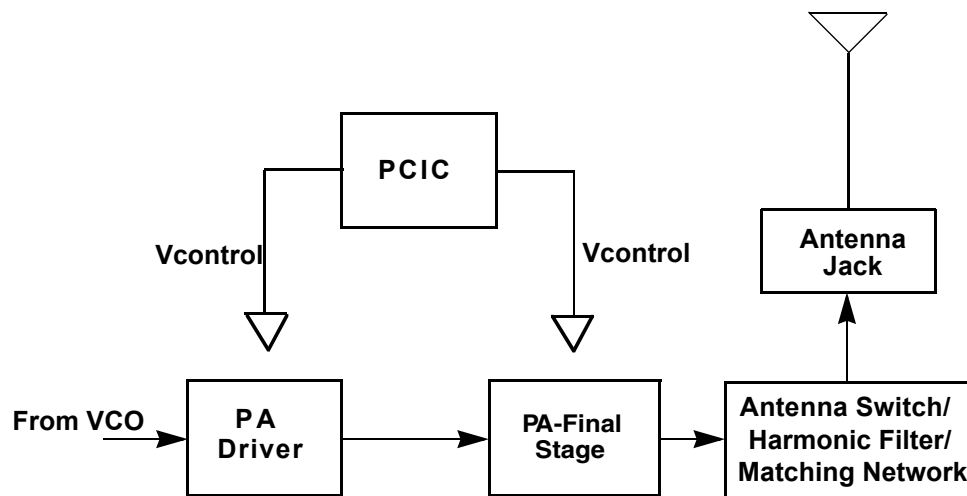

Figure 5-1: Transmitter Block Diagram

4.1 General

(Refer to Figure 5-1)

The VHF transmitter contains five basic circuits:

1. Power Amplifier
2. Antenna Switch
3. Harmonic Filter
4. Antenna Matching Network
5. Power Control Integrated Circuit (PCIC).

4.1.1 Power Amplifier

The power amplifier consists of two devices:

1. 9Z67 LDMOS driver IC (U3501) and
2. PRF1507 LDMOS PA (Q3501).

The 9Z67 LDMOS driver IC contains a 2 stage amplification with a supply voltage of 7.3V.

This RF power amplifier is capable of supplying an output power of 0.3W (pin 6 and 7) with an input signal of 2mW (3dBm) (pin16). The current drain would typically be 130mA while operating in the frequency range of 136-174MHz.

The PRF1507 LDMOS PA is capable of supplying an output power of 7W with an input signal of 0.3W. The current drain would typically be 1800mA while operating in the frequency range of 136-174MHz. The power output can be varied by changing the biasing voltage.

4.1.2 Antenna Switch

The antenna switch circuit consists of two PIN diodes (D3521 and D3551), a pi network (C3531, L3551 and C3550), and two current limiting resistors (R3571, R3572, R3573). In the transmit mode, B+ at PCIC (U3502) pin 23 will go low and turn on Q3561 where a B+ bias is applied to the antenna switch circuit to bias the diodes "on". The shunt diode (D3551) shorts out the receiver port, and the pi network, which operates as a quarter wave transmission line, transforms the low impedance of the shunt diode to a high impedance at the input of the harmonic filter. In the receive mode, the diodes are both off, and hence, there exists a low attenuation path between the antenna and receiver ports.

4.1.3 Harmonic Filter

The harmonic filter consists of C3532 to C3536, L3531 and L3532. This network forms a low-pass filter to attenuate harmonic energy of the transmitter to specifications level. The harmonic filter insertion loss should be less than 1.2dB.

4.1.4 Antenna Matching Network

A matching network which is made up of L3538 and C3537 is used to match the antenna's impedance to the harmonic filter. This will optimize the performance of the transmitter and receiver into an antenna.

4.1.5 Power Control Integrated Circuit (PCIC)

The transmitter uses the Power Control IC (PCIC), U3502 to control the power output of the radio by maintaining the radio current drain. The current to the final stage of the power module is supplied through R3519 (0.1ohms), which provides a voltage proportional to the current drain. This voltage is then fed back to the Automatic Level Control (ALC) within the PCIC to keep the whole loop stable.

The PCIC has internal digital to analog converters (DACs) which provide the reference voltage of the control loop. The voltage level is controlled by the microprocessor through the data line of the PCIC.

There are resistors and integrators within the PCIC, and external capacitors (C3562, C3563 and C3565) in controlling the transmitter rising and falling time. These are necessary in reducing the power splatter into adjacent channels.

U3503 and its associated circuitry acts as a temperature cut back circuitry. This circuitry provides the necessary voltage to the PCIC to cut the transmitter power when the radio temperature gets too high.

5.0 Receiver

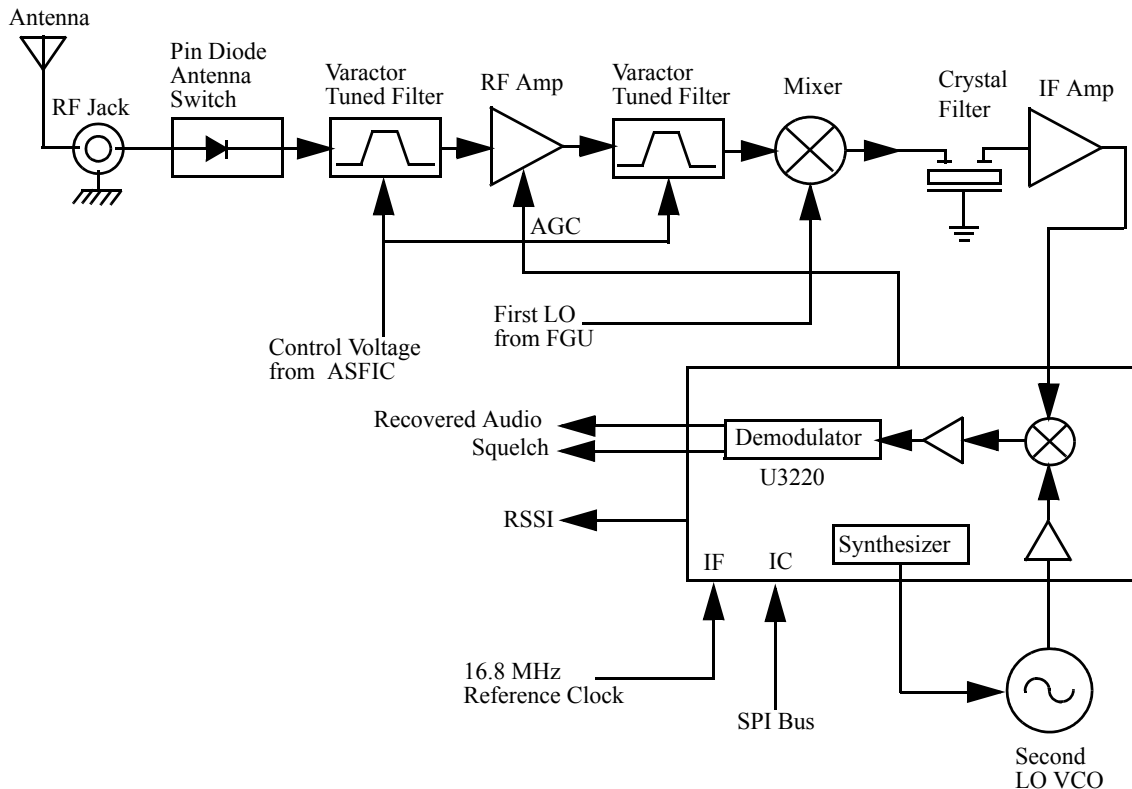

Figure 5-2: VHF Receiver Block Diagram

5.1 Receiver Front-End

(Refer to *VHF Receiver Front End Schematic Diagram* on page 5A-22, *VHF Receiver Back End Schematic Diagram* on page 5A-23, and *VHF Transmitter Schematic Diagram* on page 5A-26)

The RF signal is received by the antenna and applied to a low-pass filter. For VHF, the filter consists of L3531, L3532, C3532 to C3563. The filtered RF signal is passed through the antenna switch. The antenna switch circuit consists of two PIN diodes (D3521 and D3551) and a pi network (C3531, L3551 and C3550). The signal is then applied to a varactor tuned bandpass filter. The VHF bandpass filter comprises of L3301, L3303, C3301 to C3304 and D3301. The bandpass filter is tuned by applying a control voltage to the varactor diode (D3301) in the filter.

The bandpass filter is electronically tuned by the DACRx from IC404 which is controlled by the microprocessor. Depending on the carrier frequency, the DACRx will supply the tuned voltage to the varactor diodes in the filter. Wideband operation of the filter is achieved by shifting the bandpass filter across the band.

The output of the bandpass filter is coupled to the RF amplifier transistor Q3302 via C3306. After being amplified by the RF amplifier, the RF signal is further filtered by a second varactor tuned bandpass filter, consisting of L3305, L3306, C3311 to C3314 and D3302.

Both the pre and post-RF amplifier varactor tuned filters have similar responses. The 3 dB bandwidth of the filter is about 12 MHz. This enables the filters to be electronically controlled by using a single control voltage which is DACRx.

The output of the post-RF amplifier filter is connected to the passive double balanced mixer which consists of T3301, T3302 and CR3301. Matching of the filter to the mixer is provided by C3317, C3318 and L3308. After mixing with the first LO signal from the voltage controlled oscillator (VCO) using high side injection, the RF signal is down-converted to the 45.1 MHz IF signal.

The IF signal coming out of the mixer is transferred to the crystal filter (Y3200) through a resistor pad (R3321 - R3323) and a diplexer (C3320 and L3309). Matching to the input of the crystal filter is provided by C3200 and L3200. The crystal filter provides the necessary selectivity and intermodulation protection.

5.2 Receiver Back-End

(Refer to *VHF Receiver Back End Schematic Diagram* on page 5A-23)

The output of crystal filter Y3200 is matched to the input of IF amplifier transistor Q3200 by capacitor C3203. Voltage supply to the IF amplifier is taken from the receive 5 volts (R5). The gain controlled IF amplifier provides a maximum gain of about 10dB. The amplified IF signal is then coupled into U3220(pin 3) via L3202, C3207, and C3230 which provides the matching for the IF amplifier and U3220.

The IF signal applied to pin 3 of U3220 is amplified, down-converted, filtered, and demodulated, to produce the recovered audio at pin 27 of U3220. This IF IC is electronically programmable, and the amount of filtering (which is dependent on the radio channel spacing) is controlled by the microprocessor. Additional filtering, once externally provided by the conventional ceramic filters, is replaced by internal filters in the IF module (U3220).

The IF IC uses a type of direct conversion process, whereby the externally generated second LO frequency is divided by two in U3220 so that it is very close to the first IF frequency. The IF IC (U3220) synthesizes the second LO and phase-locks the VCO to track the first IF frequency. The second LO is designed to oscillate at twice the first IF frequency because of the divide-by-two function in the IF IC.

In the absence of an IF signal, the VCO will "search" for a frequency, or its frequency will vary close to twice the IF frequency. When an IF signal is received, the VCO will lock onto the IF signal. The second LO/VCO is a Colpitts oscillator built around transistor Q3270. The VCO has a varactor diode, D3270, to adjust the VCO frequency. The control signal for the varactor is derived from a loop filter consisting of C3278 to C3280, R3274 and R3275.

The IF IC (U3220) also performs several other functions. It provides a received signal-strength indicator (RSSI) and a squelch output. The RSSI is a dc voltage monitored by the microprocessor, and used as a peak indicator during the bench tuning of the receiver front-end varactor filter. The RSSI voltage is also used to control the automatic gain control (AGC) circuit at the front-end.

The demodulated signal on pin 27 of U3220 is also used for squelch control. The signal is routed to U404 (ASFIC) where squelch signal shaping and detection takes place. The demodulated audio signal is also routed to U404 for processing before going to the audio amplifier for amplification.

5.3 Automatic Gain Control Circuit

(Refer to *VHF Receiver Front End Schematic Diagram* on page 5A-22 and *VHF Receiver Back End Schematic Diagram* on page 5A-23)

The front end automatic gain control circuit provides automatic reduction of gain, of the front end RF amplifier via feedback. This action is necessary to prevent overloading of back end circuits. This is achieved by drawing some of the output power from the RF amplifier output. At high radio frequencies, capacitor C3327 provides the low impedance path to ground for this purpose. CR3302 is a PIN diode used for switching the path on or off. A certain amount of forward biasing current is needed to turn the PIN diode on. Transistor Q3301 provides this current.

Radio signal strength indicator, RSSI, a voltage signal, is used to drive Q3301 to saturation i.e. turned on. RSSI is produced by U3220 and is proportional to the gain of the RF amplifier and the input power to the radio.

Resistors R3304 and R3305 are voltage dividers designed to turn on Q3301 at certain RSSI levels. In order to turn on Q3301 the voltage across R3305 must be greater or equal to the voltage across R3324, plus the base-emitter voltage (V_{be}) present at Q3301. Capacitor C3209 is used to dampen any instability while the AGC is turning on. The current flowing into the collector of Q3301, a high current gain NPN transistor, will be drawn through the PIN diode to turn it on. Maximum current flowing through the PIN is limited by the resistors R3316, R3313, R3306 and R3324. C3326 is a feedback capacitor used to provide some stability to this high gain stage.

An additional gain control circuit is formed by Q3201 and its associated circuitry. Resistors R3206 and R3207 are voltage dividers designed to turn on Q3201 at a significantly higher RSSI level than the level required to turn on PIN diode control transistor Q3301. In order to turn on Q3201 the voltage across R3207 must be greater or equal to the voltage across R3208, plus the base-emitter voltage (V_{be}) present at Q3201. As current starts flowing into the collector of Q3201, it reduces the bias voltage at the base of IF amplifier transistor Q3200 and in turn, the gain of the IF amplifier. The gain can be controlled in a range of -30dB up to +10dB.

6.0 Frequency Generation Circuitry

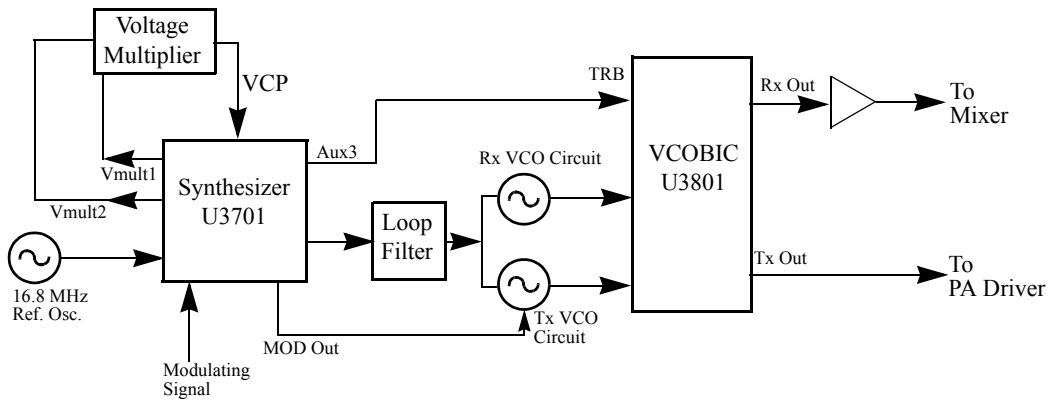

Figure 5-3: Frequency Generation Unit Block Diagram

The Frequency Generation Circuitry is composed of two main ICs, the Fractional-N synthesizer (U3701), and the VCO/Buffer IC (U3801). Designed in conjunction to maximize compatibility, the two ICs provide many of the functions that normally would require additional circuitry. The synthesizer block diagram illustrates the interconnect and support circuitry used in the region. Refer to the relevant schematics for the reference designators.

The synthesizer is powered by regulated 5V and 3.3V which come from U3711 and U3201 respectively. The synthesizer in turn generates a superfiltered 4.5V which powers U3801.

In addition to the VCO, the synthesizer must interface with the logic and ASFIC circuitry. Programming for the synthesizer is accomplished through the data, clock and chip select lines from the microprocessor. A 3.3V dc signal from synthesizer lock detect line indicates to the microprocessor that the synthesizer is locked.

Transmit modulation from the ASFIC is supplied to pin10 of U3701. Internally the audio is digitized by the Fractional-N and applied to the loop divider to provide the low-port modulation. The audio runs through an internal attenuator for modulation balancing purposes before going out to the VCO.

6.1 Synthesizer

(Refer to *VHF Synthesizer Schematic Diagram* on page 5A-24)

The Fractional-N Synthesizer uses a 16.8MHz crystal (Y3761) to provide a reference for the system. The LVFractN IC (U3701) further divides this to 2.1MHz, 2.225MHz, and 2.4MHz as reference frequencies. Together with C3761, C3762, C3763, R3761 and D3761, they build up the reference oscillator which is capable of 2.5ppm stability over temperatures of -30 to 85°C. It also provides 16.8MHz at pin 19 of U3701 to be used by ASFIC and LVZIF.

The loop filter which consist of C3721, C3722, R3721, R3722 and R3723 provides the necessary dc steering voltage for the VCO and determines the amount of noise and spur passing through.

In achieving fast locking for the synthesizer, an internal adapt charge pump provides higher current at pin 45 of U3701 to put synthesizer within the lock range. The required frequency is then locked by normal mode charge pump at pin 43.

Both the normal and adapt charge pumps get their supply from the capacitive voltage multiplier which is made up of C3701 to C3704 and triple diodes D3701, D3702. Two 3.3V square waves (180 deg out of phase) are first multiplied by four and then shifted, along with regulated 5V, to build up 13.5V at pin 47 of U3701.

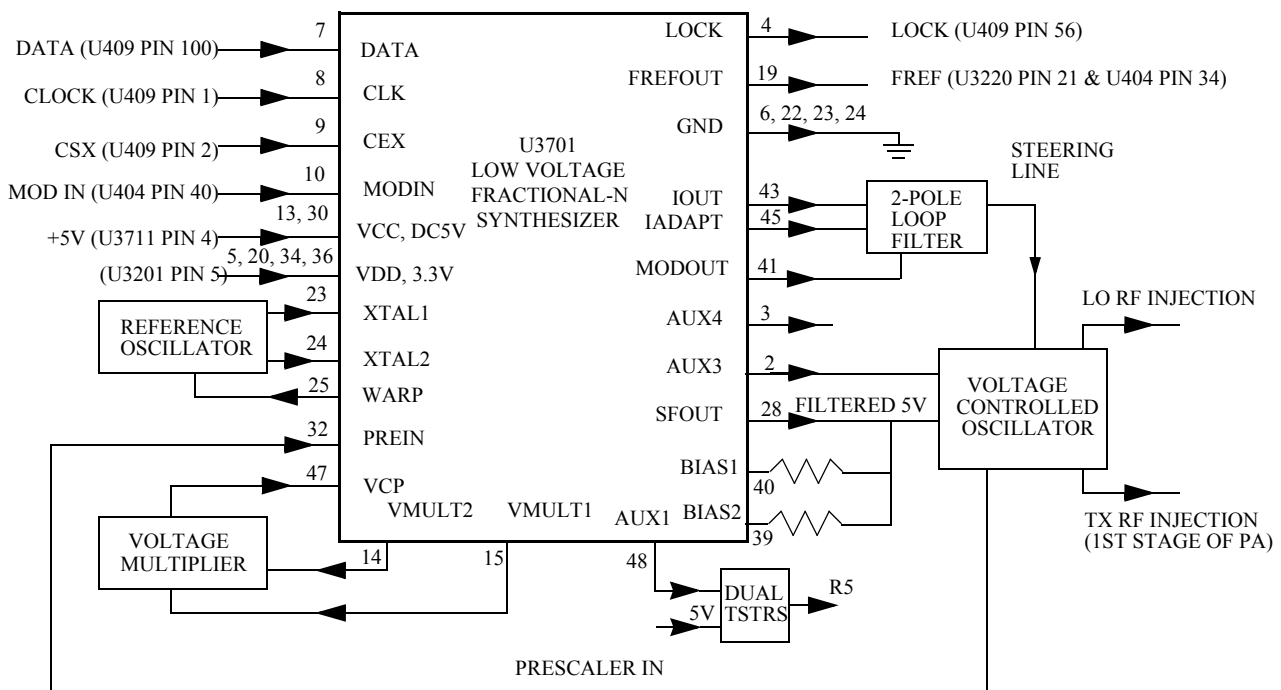

Figure 5-4: Synthesizer Block Diagram

6.2 VCO - Voltage Controlled Oscillator

(Refer to VHF Voltage Controlled Oscillator Schematic Diagram on page 5A-25)

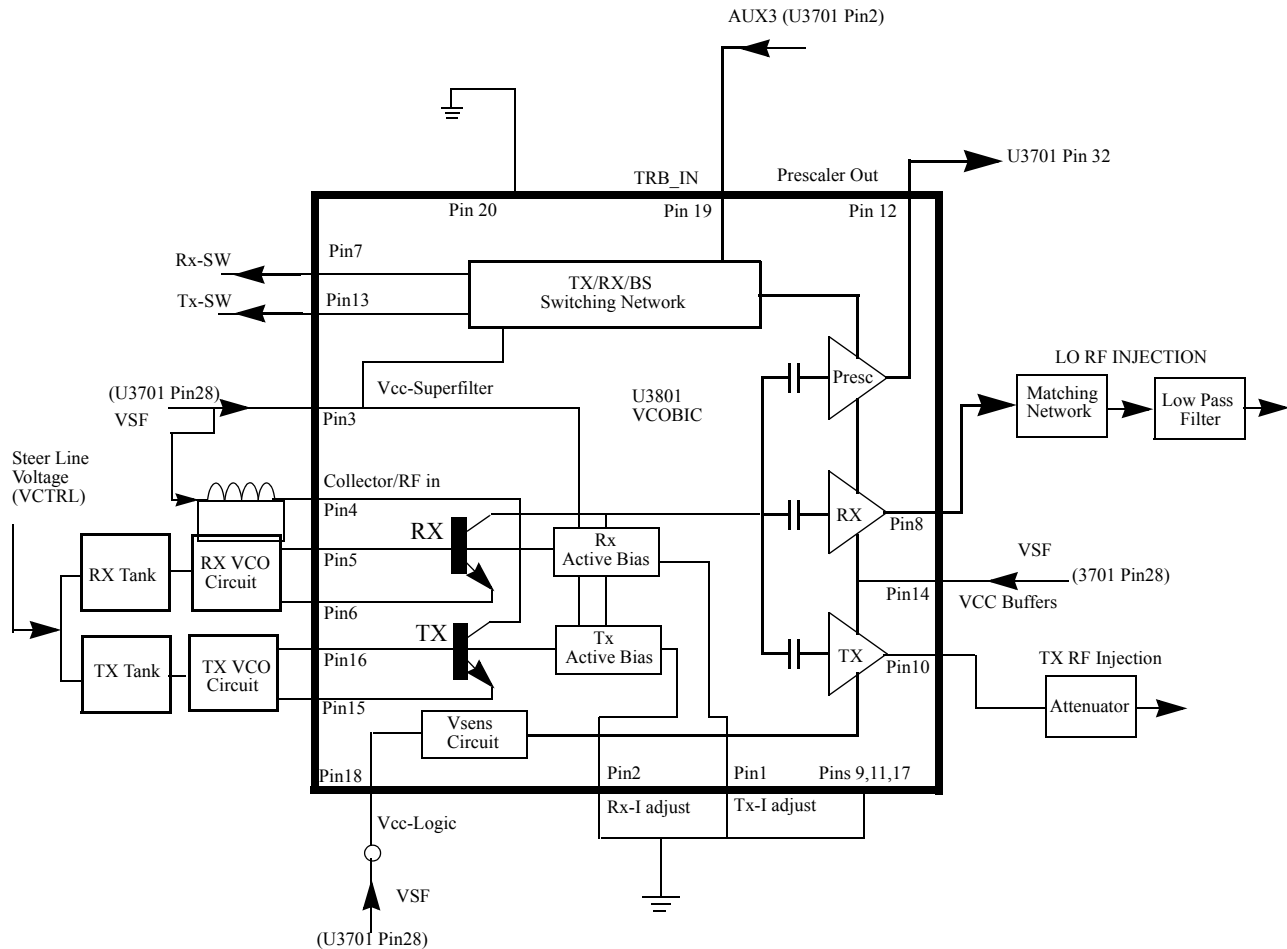

Figure 5-5: VCO Block Diagram

The VCOBIC (U3801) in conjunction with the Fractional-N synthesizer (U3701) generates RF in both the receive and the transmit modes of operation. The TRB line (U3801 pin 19) determines which oscillator and buffer will be enabled. A sample of the RF signal from the enabled oscillator is routed from U3801 pin 12, through a low pass filter, to the prescaler input (U3701 pin 32). After frequency comparison in the synthesizer, a resultant CONTROL VOLTAGE is received at the VCO. This voltage is a DC voltage typically between 3.5V and 9.5V when the PLL is locked on frequency.

The RF section of the VCOBIC(U3801) is operated at 4.54 V (VSF), while the control section of the VCOBIC and Fractional-N synthesizer (U3701) is operated at 3.3V. The operation logic is shown in Table 5-1.

Table 5-1: VCO Control Logic

Desired Mode	AUX 4	AUX 3	TRB
Tx	n.u.	High (@3.2V)	High (@3.2V)
Rx	n.u.	Low	Low
Battery Saver	n.u.	Hi-Z/Float (@1.6V)	Hi-Z/Float (@1.6V)

In the receive mode, U3801 pin 19 is low or grounded. This activates the receive VCO by enabling the receive oscillator and the receive buffer of U3801. The RF signal at U3801 pin 8 is run through a matching network. The resulting RF signal is the LO RF INJECTION and it is applied to the mixer at T3302.

During the transmit condition, when PTT is depressed, 3.2 volts is applied to U3801 pin 19. This activates the transmit VCO by enabling the transmit oscillator and the transmit buffer of U3801. The RF signal at U3801 pin 10 is injected into the input of the PA module (U3501 pin16). This RF signal is the TX RF INJECTION. Also in transmit mode, the audio signal to be frequency modulated onto the carrier is received through U3701 pin 41.

When a high impedance is applied to U3801 pin19, the VCO is operating in BATTERY SAVER mode. In this case, both the receive and transmit oscillators as well as the receive transmit and prescaler buffer are turned off.

7.0 Notes For All Schematics and Circuit Boards

* Component is frequency sensitive. Refer to the Electrical Parts List for value and usage.

1. Unless otherwise stated, resistances are in Ohms ($k = 1000$), and capacitances are in picofarads (pF) or microfarads (μF).
2. DC voltages are measured from point indicated to chassis ground using a Motorola DC multimeter or equivalent. Transmitter measurements should be made with a $1.2 \mu H$ choke in series with the voltage probe to prevent circuit loading.
3. Reference Designators are assigned in the following manner:
 - 400/500 Series = Controller
 - 600 Series = Keypad Board
 - 3200 Series = IF Circuitry
 - 3300 Series = Receiver
 - 3500 Series = Transmitter
 - 3700 and 3800 Series = Frequency Generation
4. Interconnect Tie Point Legend:
 - UNSWB+ = Unswitch Battery Voltage (7.5V)
 - SWB+ = Switch Battery Voltage (7.5V)
 - R5 = Receiver Five Volts
 - CLK = Clock
 - Vdda = Regulated 3.3 Volts (for analog)
 - Vddd = Regulated 3.3 Volts (for digital)
 - CSX = Chip Select Line (not for LVZIF)
 - SYN = Synthesizer
 - DACRX = Digital to Analog Voltage (For Receiver Front End Filter)
 - VSF = Voltage Super Filtered (5 volts)
 - VR = Voltage Regulator

6-LAYER CIRCUIT BOARD DETAIL VIEWING COPPER STEPS IN PROPER LAYER SEQUENCE

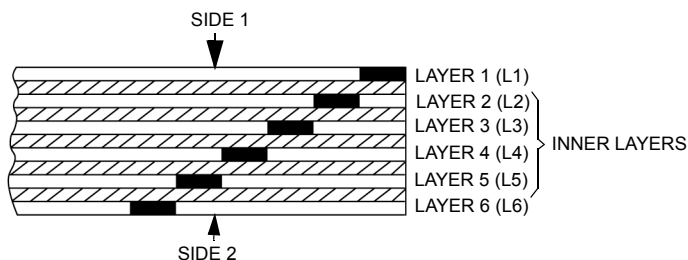

THIS PAGE INTENTIONALLY LEFT BLANK

8.0 Circuit Board/Schematic Diagrams and Parts List

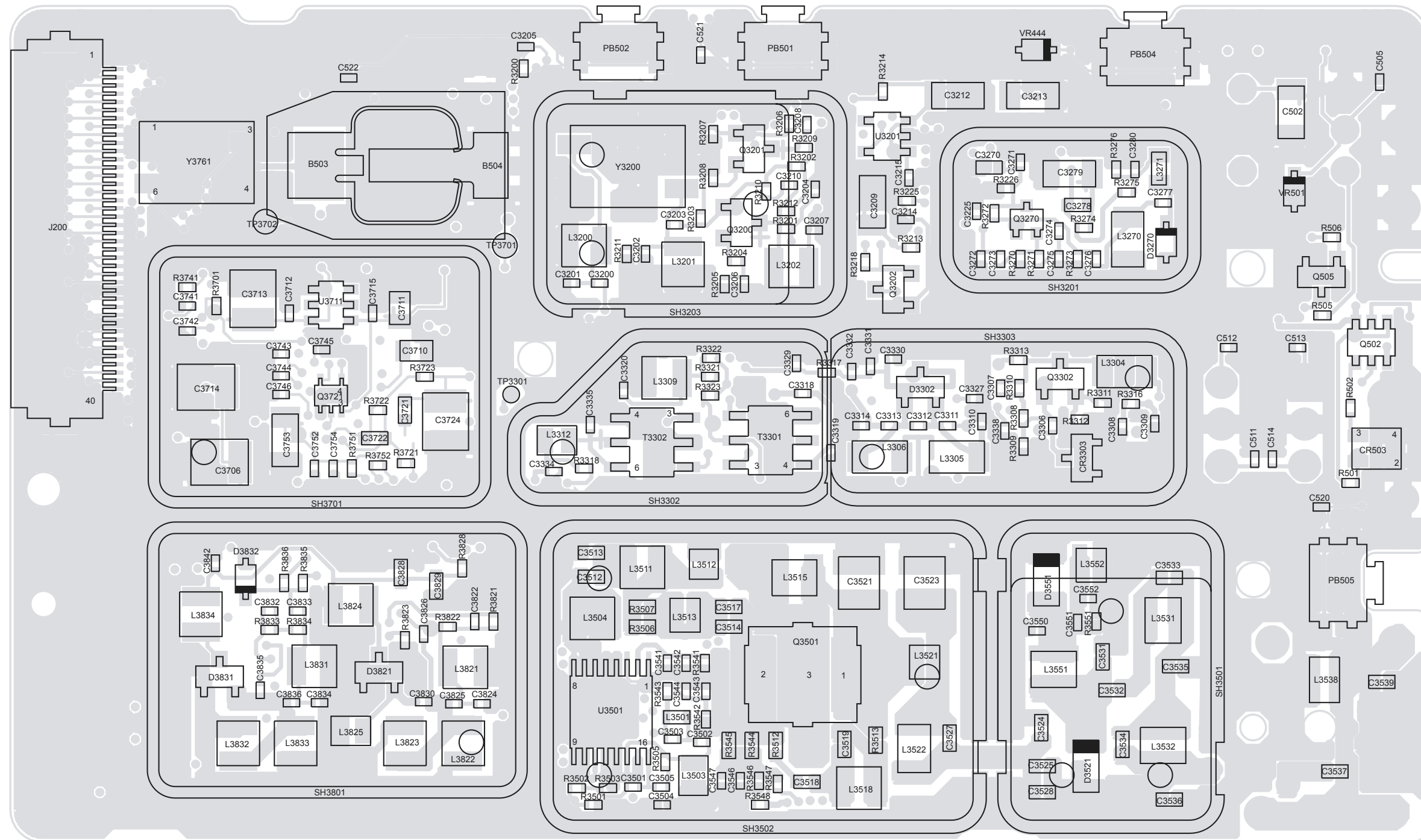

ZMY0130792-O

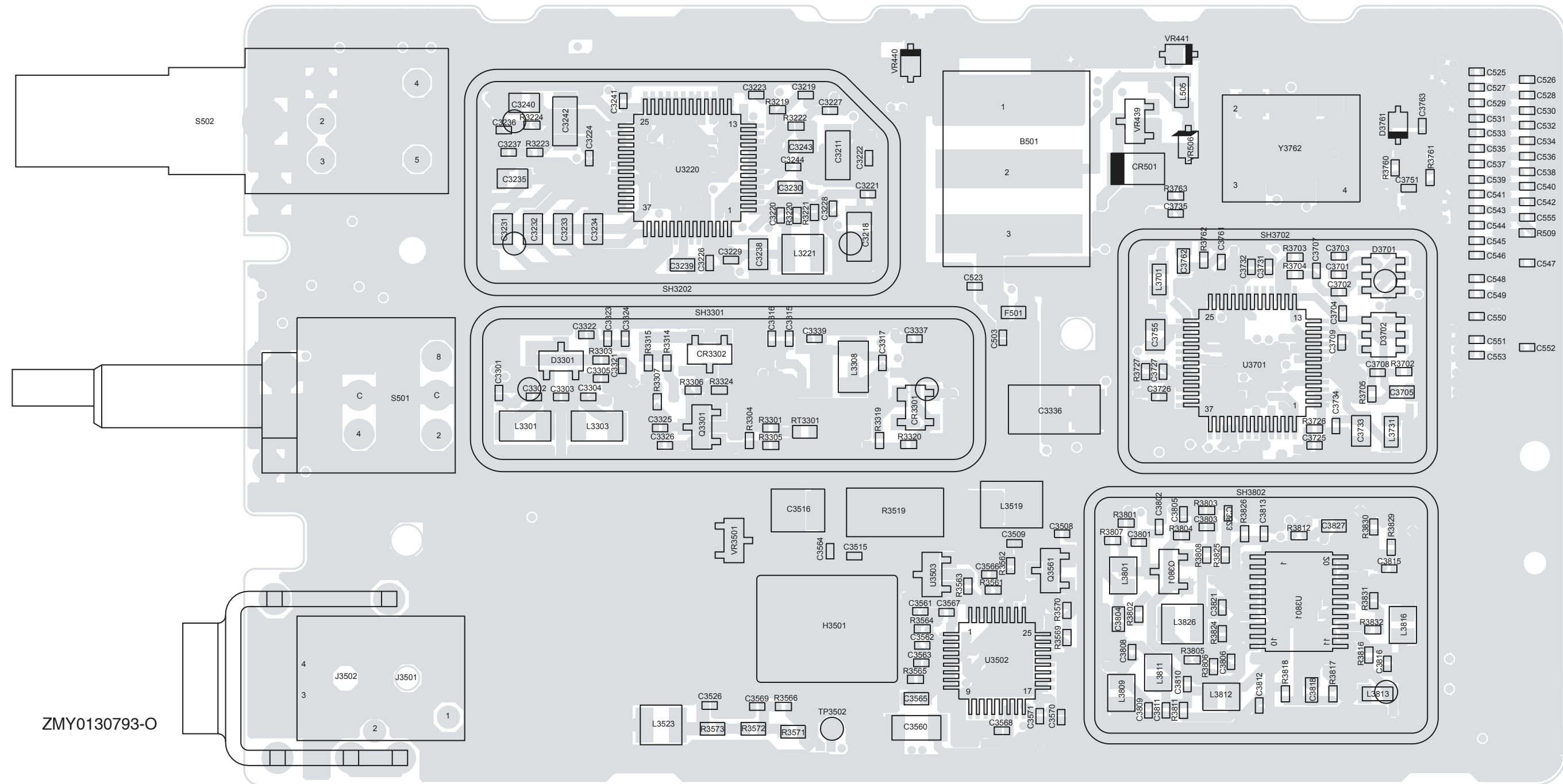

VHF (136-174MHz) Main Board Bottom Side
PCB No. 8404055G05/G06/G07

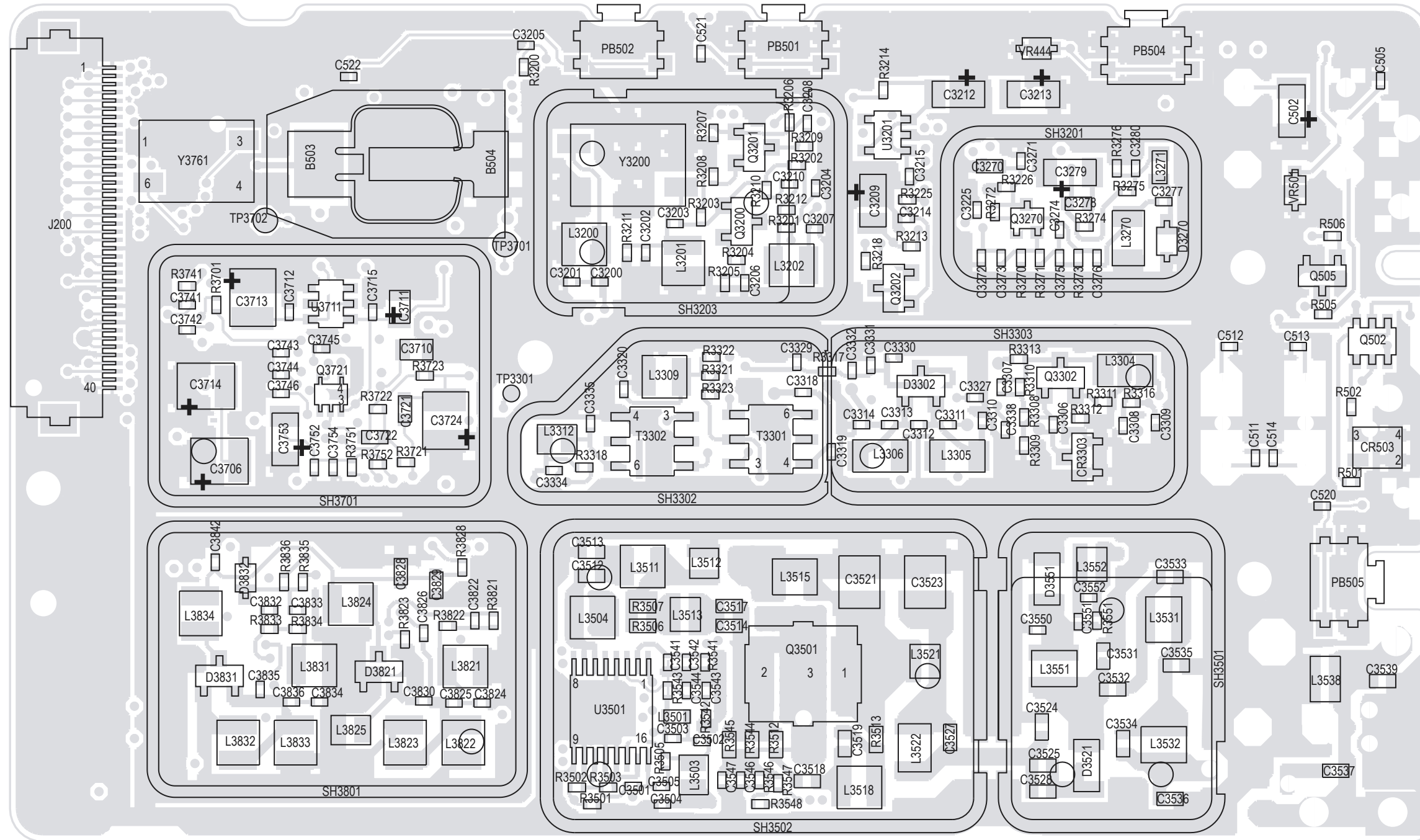

ZMY0130792-A

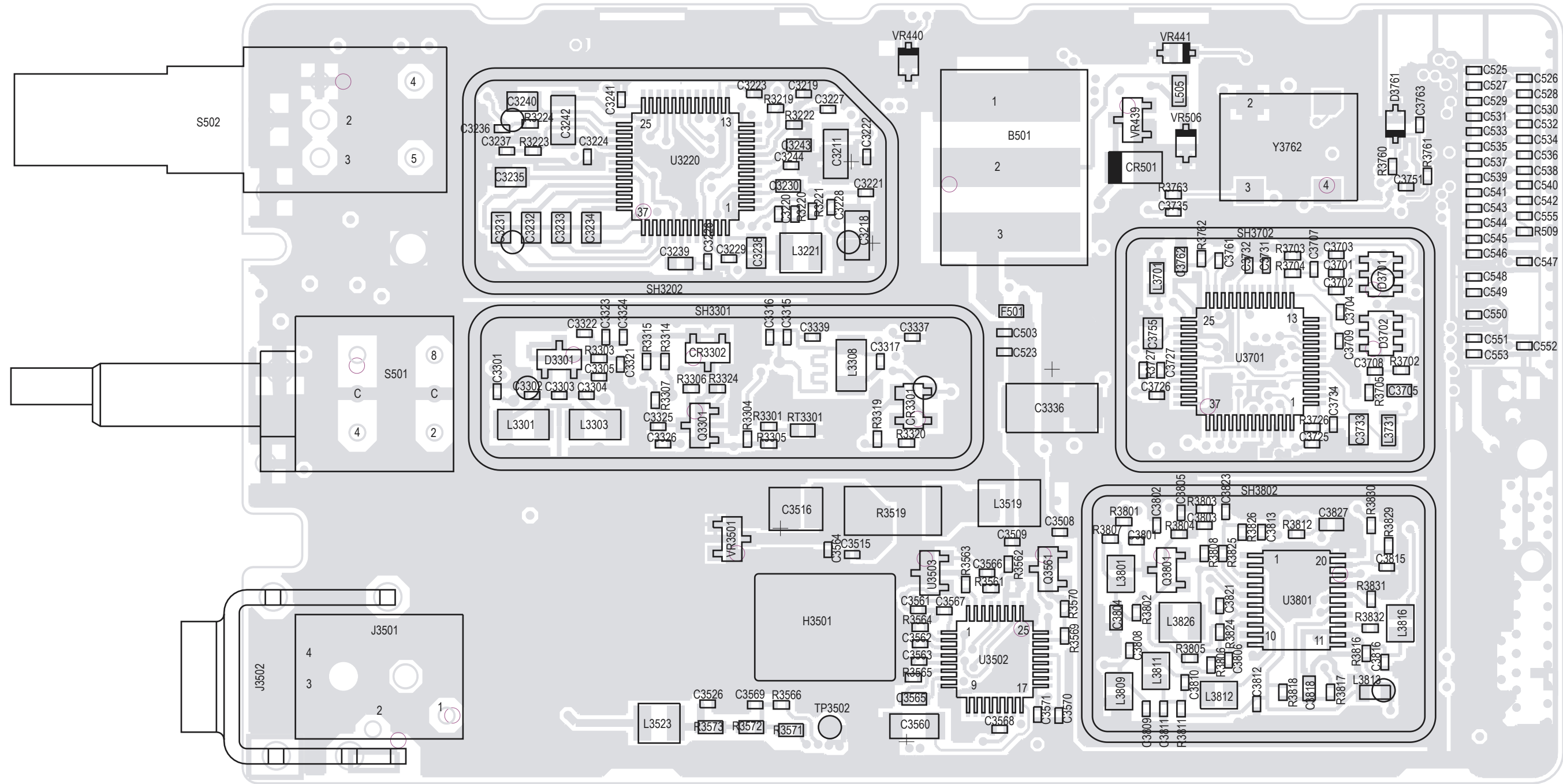

ZMY0130793-A

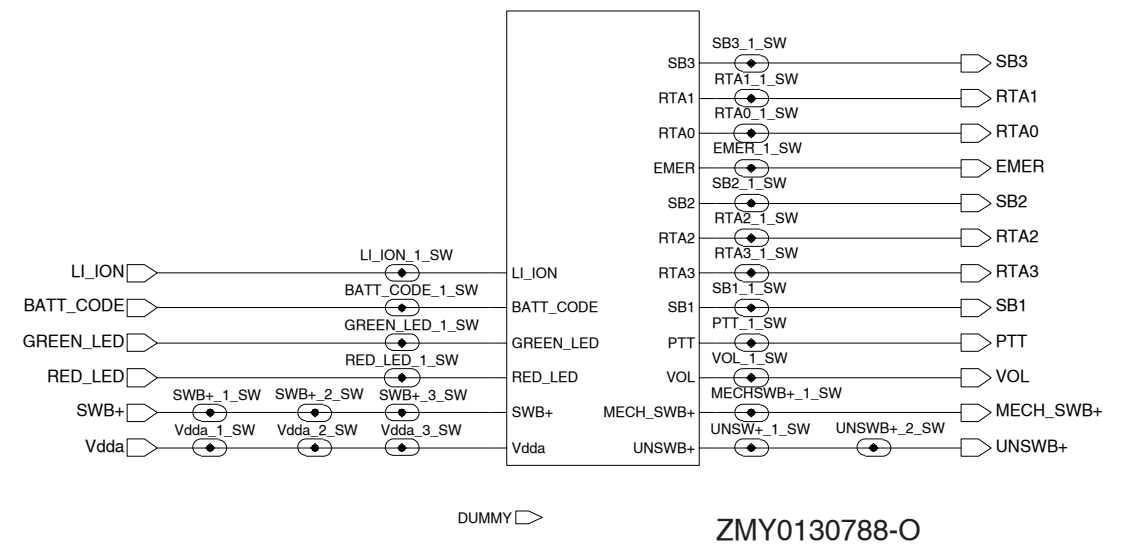
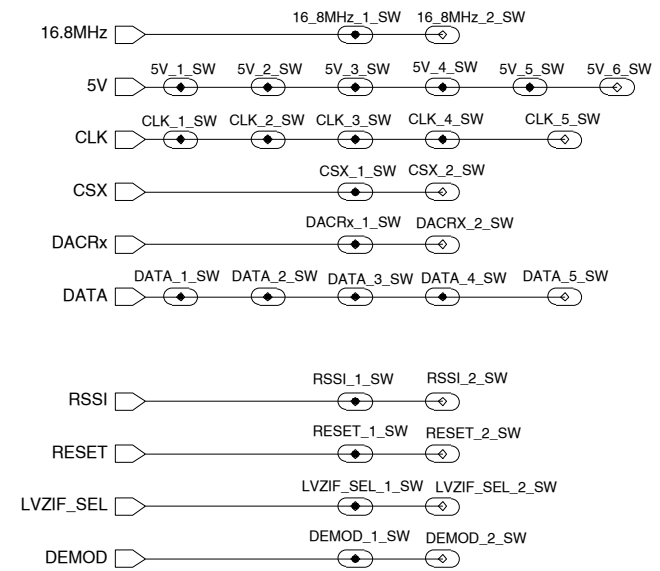
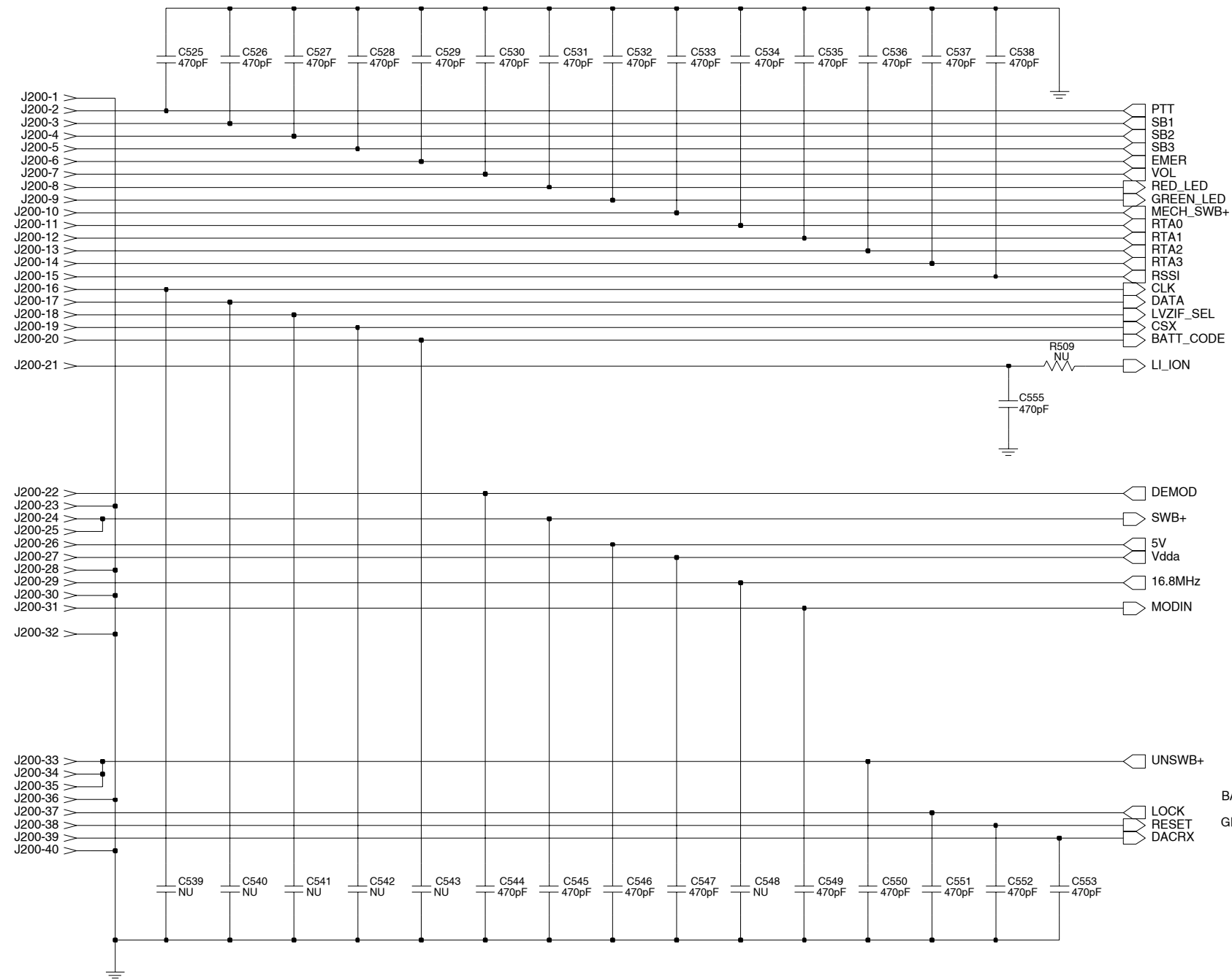

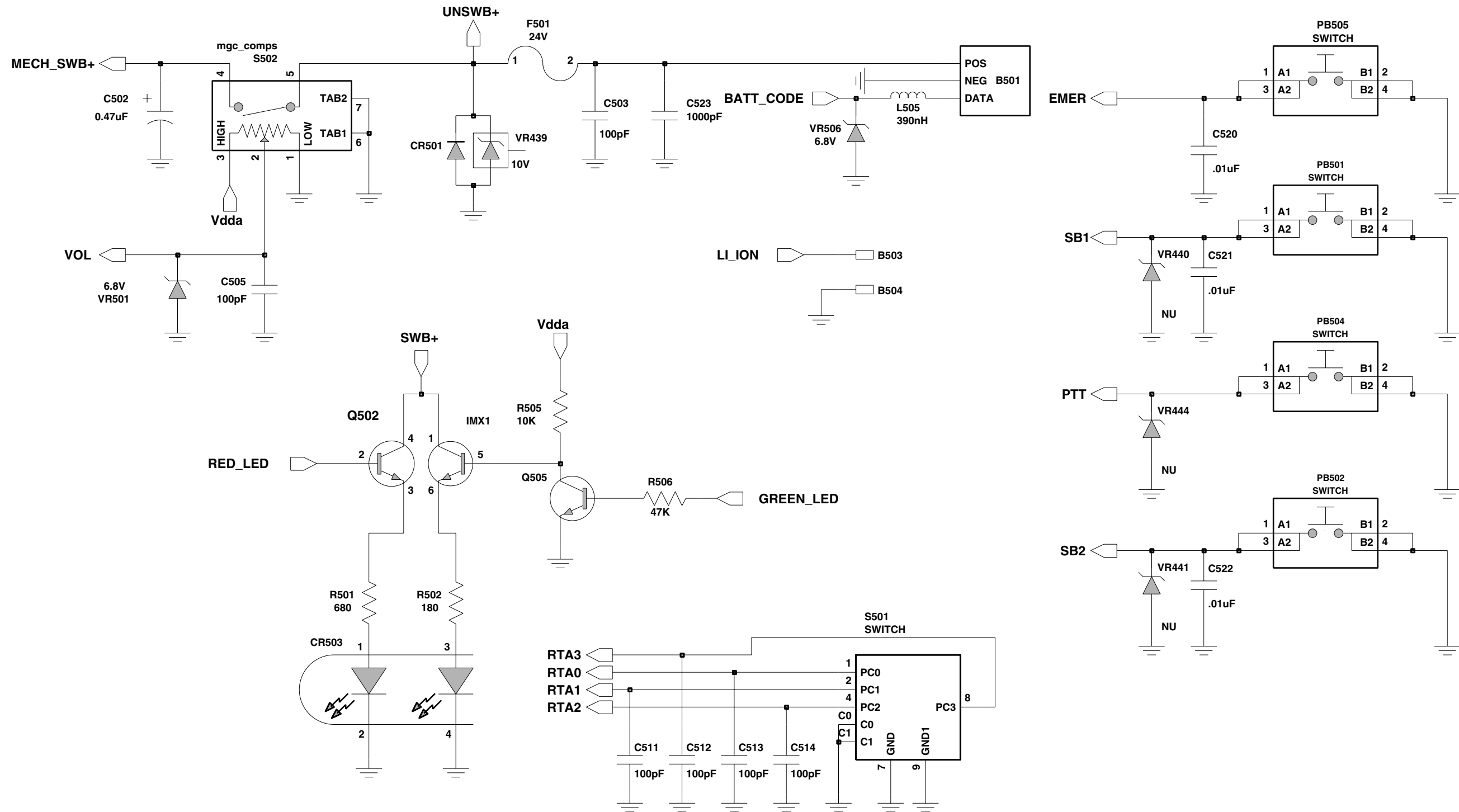

VHF Controls And Switches Schematic Diagram (sheet 2 of 2)

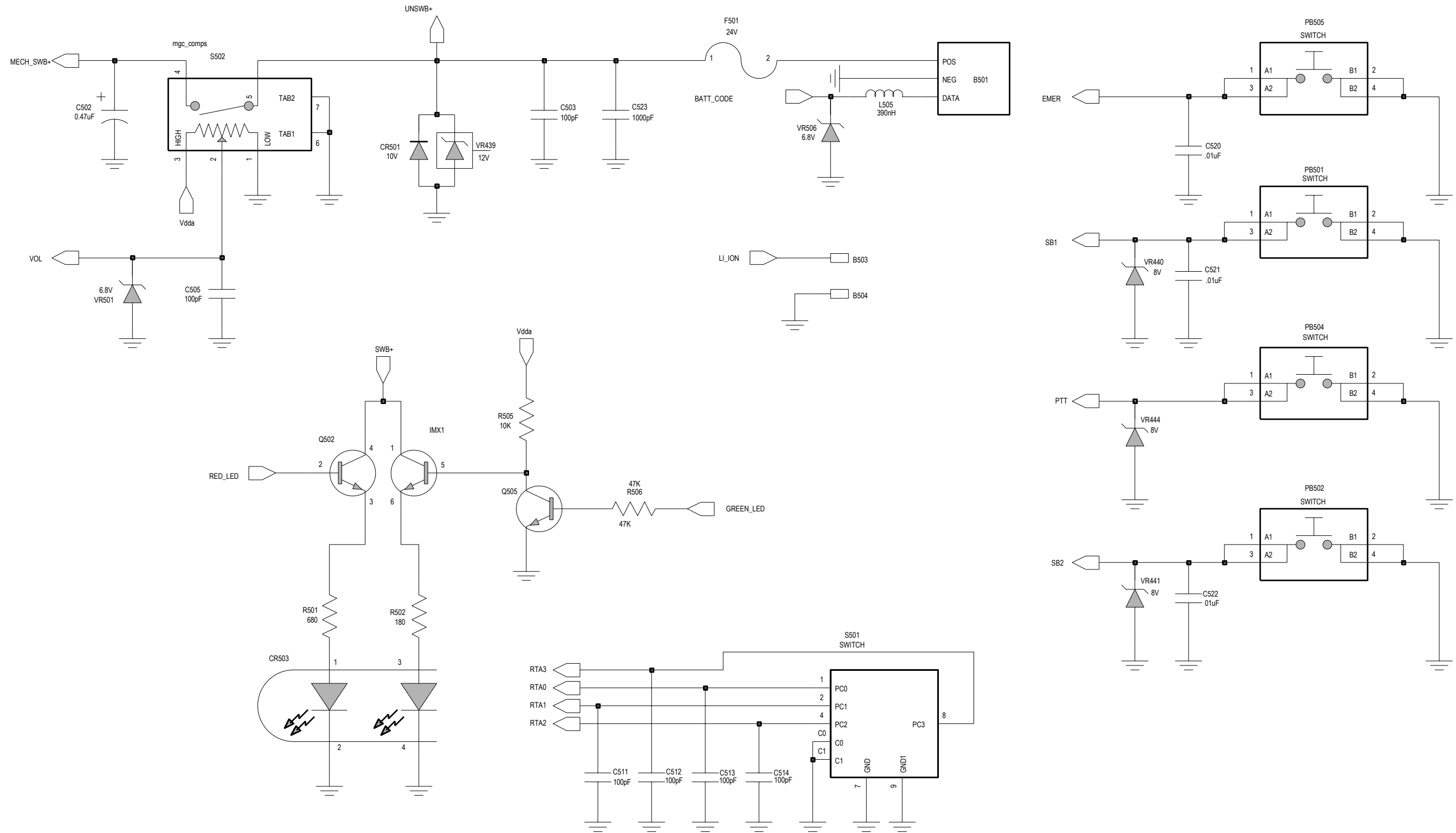

VHF Controls And Switches Schematic Diagram
 (sheet 2 of 2 for 8404055G09 PCB)

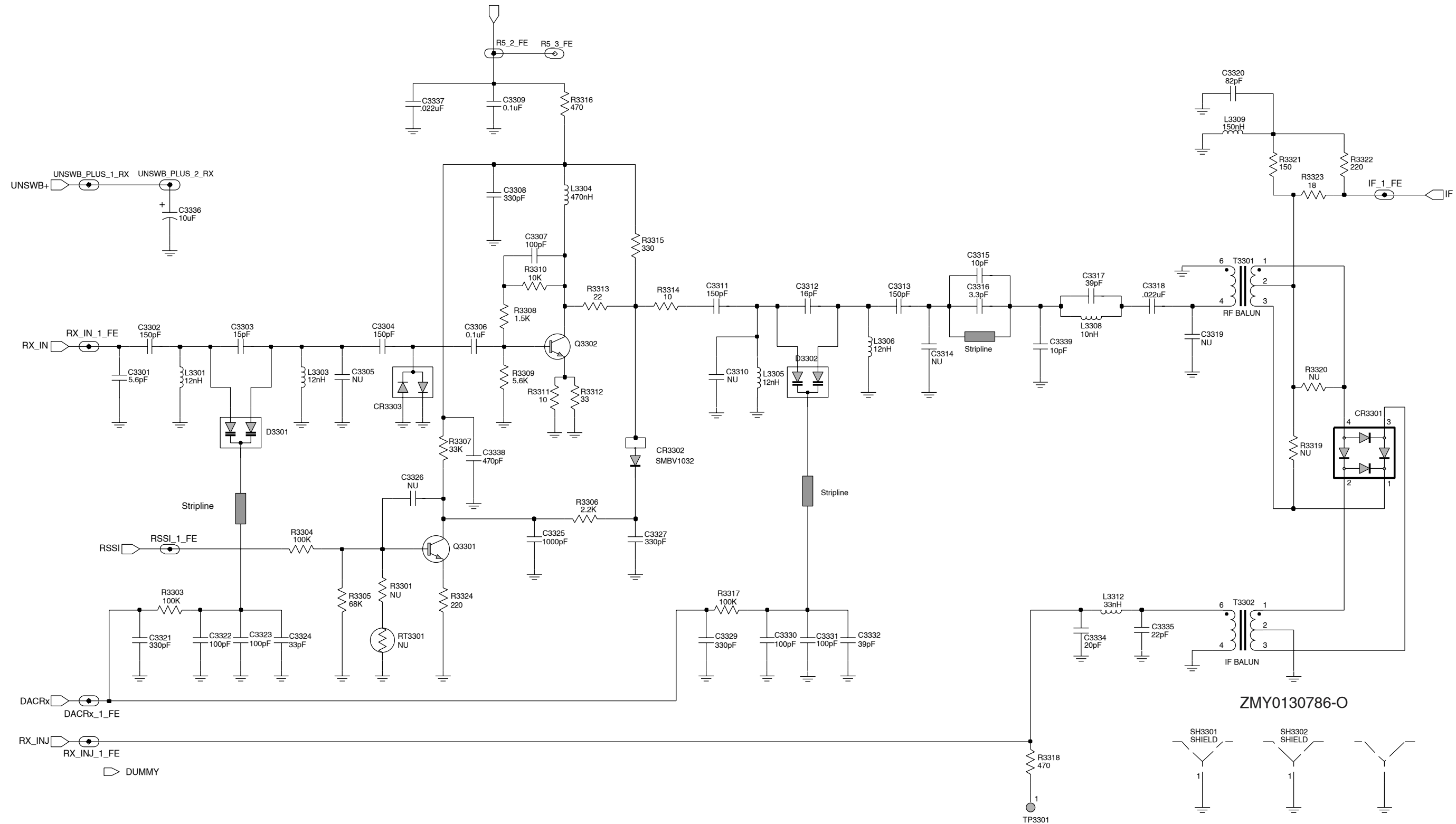

VHF Receiver Front End Schematic Diagram

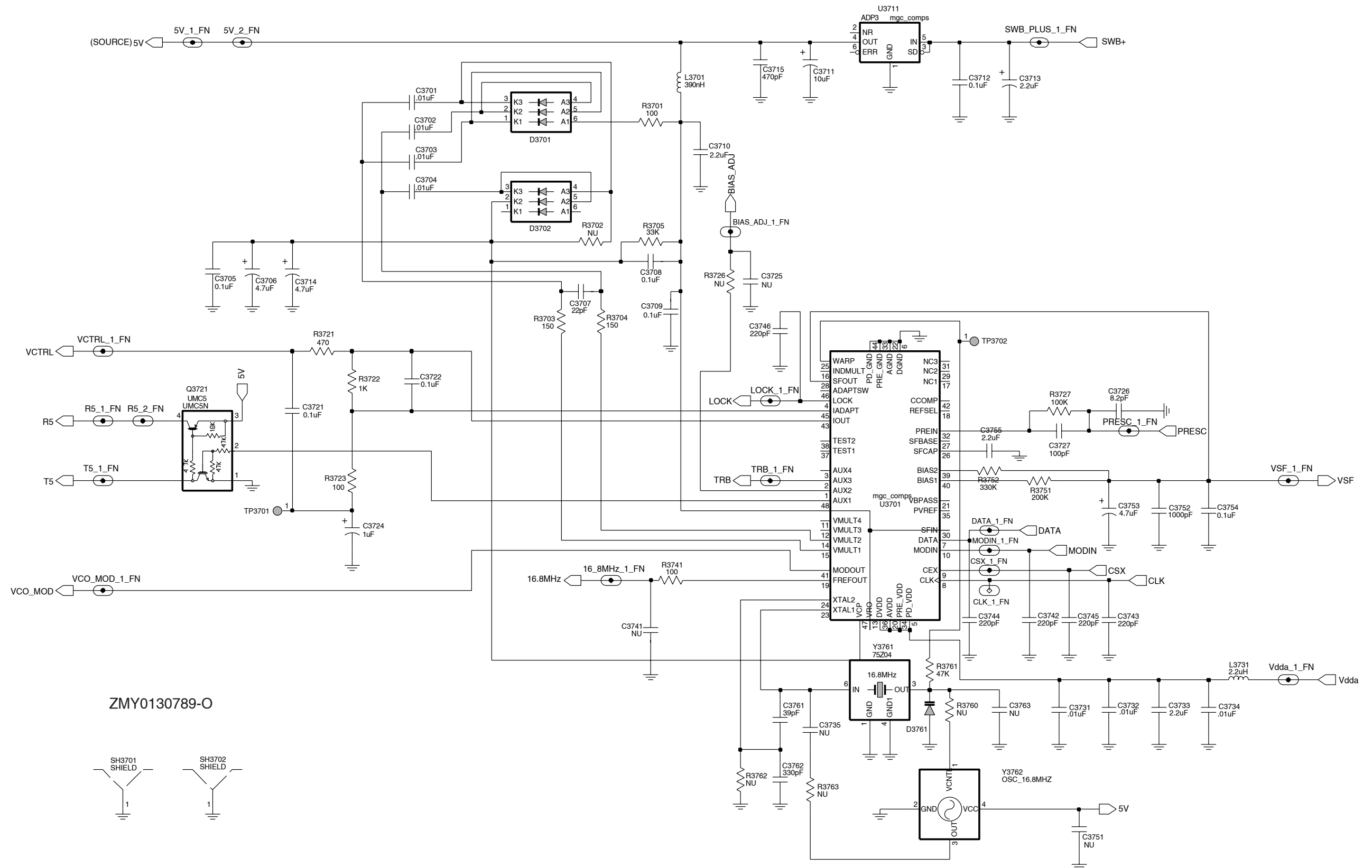

VHF Synthesizer Schematic Diagram

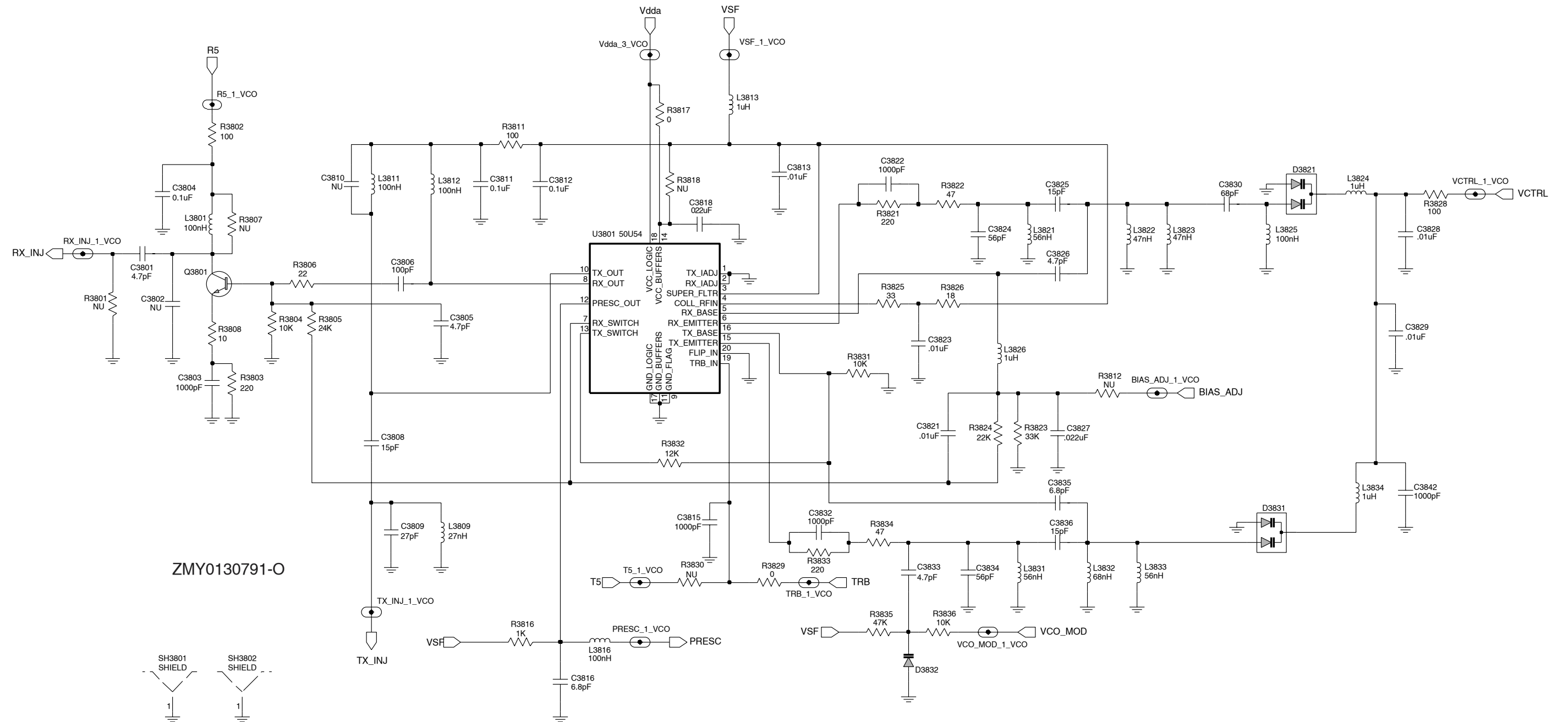

VHF Voltage Controlled Oscillator Schematic Diagram

VHF Radio Parts List (RF Board)

Circuit Ref	Motorola Part No.	Description
B501	0986237A02	Battery Contact Module
B501	0986237A02	Battery Contact Connector
B503	3980502Z01	Contact, Backup B+ (not used in GP328 Plus)
B504	3980501Z01	Contact, Backup B- (not used in GP328 Plus)
C3200	2113743N31	16.0 pF, 5%
C3201	NOT PLACED	
C3202	NOT PLACED	
C3203	2113743N50	100 pF, 5%
C3204	2113743L41	10000 pF, 10%
C3205	2113928N01	0.1 uF, 10%
C3206	2113743L41	10000 pF, 10%
C3207	2113743N10	2.2 pF, 0.25 pF
C3208	NOT PLACED	
C3209	2311049A07	1.0 uF, 10%
C3210	2113743L17	1000 pF, 10%
C3211	2311049A56	4.7 uF
C3212	2311049A07	1.0 uF, 10%
C3213	2311049A56	4.7 uF
C3214	2113928N01	0.1 uF, 10%
C3215	2113743N26	10.0 pF, 5%
C3218	2311049A56	4.7 uF
C3219	2113928N01	0.1 uF, 10%
C3220	2113743N26	10.0 pF, 5%
C3221	2113743L41	10000 pF, 10%
C3222	2113928N01	0.1 uF, 10%
C3223	2113928N01	0.1 uF, 10%
C3224	2113928N01	0.1 uF, 10%
C3225	2113928N01	0.1 uF, 10%
C3226	2113928N01	0.1 uF, 10%
C3227	2113743L41	10000 pF, 10%
C3228	2113743L41	10000 pF, 10%
C3229	2113743N50	100 pF, 5%
C3230	2113740F51	100 pF
C3231	2180478Z20	1.0 uF
C3232	2180478Z20	1.0 uF
C3233	2180478Z20	1.0 uF
C3234	2180478Z20	1.0 uF
C3235	2113743A23	0.220 uF, 10%
C3236	NOT PLACED	
C3237	NOT PLACED	
C3238	2113743A24	0.330 uF, 10%
C3239	2113743E07	0.022 uF
C3240	2113743A23	0.220 uF, 10%
C3241	2113743L19	1200 pF, 10%
C3242	2109720D14	0.1 uF
C3243	2113743E07	0.022 uF
C3244	2113743L41	10000 pF, 10%

Circuit Ref	Motorola Part No.	Description
C3270	2113743E07	0.022 uF
C3271	2113743L05	330 pF, 10%
C3272	2113743N18	4.7 pF, 0.25 pF
C3273	2113743N26	10.0 pF, 5%
C3274	2113743N38	33.0 pF, 5%
C3275	2113743N44	56.0 pF, 5%
C3276	2113743N42	47.0 pF, 5%
C3277	2113743N48	82.0 pF, 5%
C3278	2113743E07	0.022 uF
C3279	2311049A40	2.2 uF, 10%
C3280	2113743L41	10000 pF, 10%
C3301	2113743N20	5.6 pF, 0.5 pF
C3302	2113743N54	150 pF, 5%
C3303	2113743N30	15.0 pF, 5%
C3304	2113743N54	150 pF, 5%
C3305	NOT PLACED	
C3306	2113928N01	0.1 uF, 10%
C3307	2113743N50	100 pF, 5%
C3308	2113743L05	330 pF, 10%
C3309	2113928N01	0.1 uF, 10%
C3310	NOT PLACED	
C3311	2113743N54	150 pF, 5%
C3312	2113743N31	16.0 pF, 5%
C3313	2113743N54	150 pF, 5%
C3314	NOT PLACED	
C3315	2113743N26	10.0 pF, 5%
C3316	2113743N14	3.3 pF, 0.25 pF
C3317	2113743N40	39.0 pF, 5%
C3318	2113743M08	22000PF, +80% / -20%
C3319	NOT PLACED	
C3320	2113743N48	82.0 pF, 5%
C3321	2113743L05	330 pF, 10%
C3322	2113743N50	100 pF, 5%
C3323	2113743N50	100 pF, 5%
C3324	2113743N38	33.0 pF, 5%
C3325	2113743L17	1000 pF, 10%
C3326	NOT PLACED	
C3327	2113743L05	330 pF, 10%
C3329	2113743L05	330 pF, 10%
C3330	2113743N50	100 pF, 5%
C3331	2113743N50	100 pF, 5%
C3332	2113743N40	39.0 pF, 5%
C3334	2113743N33	20.0 pF, 5%
C3335	2113743N34	22.0 pF, 5%
C3336	2311049A18	10 uF, 10%
C3337	2113743M08	22000PF, +80% / -20%
C3338	2113743L09	470 pF, 10%
C3339	2113743N26	10.0 pF, 5%
C3501	2113743L05	330 pF, 10%
C3502	2113743N38	33.0 pF, 5%
C3503	2113743N38	33.0 pF, 5%

Circuit Ref	Motorola Part No.	Description
C3504	2113743M08	22000PF, +80% / -20%
C3505	2113743N38	33.0 pF, 5%
C3508	2113743M08	22000PF, +80% / -20%
C3509	2113743L05	330 pF, 10%
C3512	2113740F43	47 pF
C3513	2113740F38	30 pF
C3514	2113740F47	68 pF
C3515	2113743L29	3300 pF, 10%
C3516	2311049A08	1 uF
C3517	2113740F47	68 pF
C3518	NOT PLACED	
C3519	NOT PLACED	
C3521	2111078B51	220 uF
C3523	2111078B44	120 uF
C3524	2113740F34	20 pF
C3525	2113740F27	10 pF
C3526	2113743M08	22000PF, +80% / -20%
C3527	NOT PLACED	
C3528	2113740F27	10 pF
C3531	2113740F34	20 pF
C3532	2113740F47	68 pF
C3533	2113740F24	7.5 pF
C3534	2113740F19	4.7 pF
C3535	2113740F37	27 pF
C3536	2113740F31	15 pF
C3537	2113740F33	18 pF
C3539	2113740F29	12 pF
C3541	2113743M08	22000PF, +80% / -20%
C3542	2113743L05	330 pF, 10%
C3543	2113743M08	22000PF, +80% / -20%
C3544	2113743L05	330 pF, 10%
C3546	2113743L05	330 pF, 10%
C3547	2113743M08	22000PF, +80% / -20%
C3550	2113743N23	7.5 pF, 0.5 pF
C3551	2113743N46	68.0 pF, 5%
C3552	2113743N44	56.0 pF, 5%
C3560	2311049A07	1.0 uF, 10%
C3561	2113743M08	22000PF, +80% / -20%
C3562	2113743L29	3301 pF, 10%
C3563	2113743L29	3302 pF, 10%
C3564	2113743L01	220 pF, 10%
C3565	2113743E07	0.022 uF
C3566	2113743N50	100 pF, 5%
C3567	2113743L05	330 pF, 10%
C3568	2113743L29	3303 pF, 10%
C3569	2113743M08	22000PF, +80% / -20%
C3570	2113743L05	330 pF, 10%
C3571	2113743L09	470 pF, 10%
C3701	2113743L41	10000 pF, 10%
C3702	2113743L41	10000 pF, 10%
C3703	2113743L41	10000 pF, 10%

Circuit Ref	Motorola Part No.	Description
C3704	2113743L41	10000 pF, 10%
C3705	2113743E20	0.10 uF, 10%
C3706	2311049J11	4.7 uF, 10%
C3707	2113743N34	22.0 pF, 5%
C3708	2113928N01	0.1 uF, 10%
C3709	2113928N01	0.1 uF, 10%
C3710	2104993J02	2.2 uF
C3711	2311049A69	10.0 uF, 20%
C3712	2113928N01	0.1 uF, 10%
C3713	2311049A09	2.2 uF, 10%
C3714	2311049J11	4.7 uF, 10%
C3715	2113743L09	470 pF, 10%
C3721	2113743E20	0.10 uF, 10%
C3722	2113743E20	0.10 uF, 10%
C3724	2311049A08	1 uF
C3725	NOT PLACED	
C3726	2113743N24	8.2 pF, 0.5 pF
C3727	2113743N50	100 pF, 5%
C3731	2113743L41	10000 pF, 10%
C3732	2113743L41	10000 pF, 10%
C3733	2104993J02	2.2 uF
C3734	2113743L41	10000 pF, 10%
C3735	NOT PLACED	
C3741	NOT PLACED	
C3742	2113743L01	220 pF, 10%
C3743	2113743L01	220 pF, 10%
C3744	2113743L01	220 pF, 10%
C3745	2113743L01	220 pF, 10%
C3746	2113743L01	220 pF, 10%
C3751	NOT PLACED	
C3752	2113743L17	1000 pF, 10%
C3753	2311049A56	4.7 uF
C3754	2113928N01	0.1 uF, 10%
C3755	2104993J02	2.2 uF
C3761	2113743N40	39.0 pF, 5%
C3762	2113740F63	330 pF, 5%
C3763	NOT PLACED	
C3801	2113743N18	4.7 pF, 0.25 pF
C3802	NOT PLACED	
C3803	2113743L17	1000 pF, 10%
C3804	2113743E20	0.10 uF, 10%
C3805	2113743N18	4.7 pF, 0.25 pF
C3806	2113743N50	100 pF, 5%
C3808	2113743N30	15.0 pF, 5%
C3809	2113743N36	27.0 pF, 5%
C3810	NOT PLACED	
C3811	2113928N01	0.1 uF, 10%
C3812	2113928N01	0.1 uF, 10%
C3813	2113743L41	10000 pF, 10%
C3815	2113743L17	1000 pF, 10%
C3816	2113743N22	6.8 pF, 0.5 pF

Circuit Ref	Motorola Part No.	Description
C3818	2113743E07	0.022 uF
C3821	2113743L41	10000 pF, 10%
C3822	2113743L17	1000 pF, 10%
C3823	2113743L41	10000 pF, 10%
C3824	2113743N44	56.0 pF, 5%
C3825	2113743N30	15.0 pF, 5%
C3826	2113743N18	4.7 pF, 0.25 pF
C3827	2113743E07	0.022 uF
C3828	2185895Z01	0.01 uF
C3829	2185895Z01	0.01 uF
C3830	2113743N46	68.0 pF, 5%
C3832	2113743L17	1000 pF, 10%
C3833	2113743N18	4.7 pF, 0.25 pF
C3834	2113743N44	56.0 pF, 5%
C3835	2113743N22	6.8 pF, 0.5 pF
C3836	2113743N30	15.0 pF, 5%
C3842	2113743L17	1000 pF, 10%
C502	2311049A05	0.47 uF, 10%
C503	2113743N50	100 pF, 5%
C505	2113743N50	100 pF, 5%
C511	2113743N50	100 pF, 5%
C512	2113743N50	100 pF, 5%
C513	2113743N50	100 pF, 5%
C514	2113743N50	100 pF, 5%
C520	2113743L41	10000 pF, 10%
C521	2113743L41	10000 pF, 10%
C522	2113743L41	10000 pF, 10%
C523	2113743L17	1000 pF, 10%
C525	2113743L09	470 pF, 10%
C526	2113743L09	470 pF, 10%
C527	2113743L09	470 pF, 10%
C528	2113743L09	470 pF, 10%
C529	2113743L09	470 pF, 10%
C530	2113743L09	470 pF, 10%
C531	2113743L09	470 pF, 10%
C532	2113743L09	470 pF, 10%
C533	2113743L09	470 pF, 10%
C534	2113743L09	470 pF, 10%
C535	2113743L09	470 pF, 10%
C536	2113743L09	470 pF, 10%
C537	2113743L09	470 pF, 10%
C538	2113743L09	470 pF, 10%
C539	NOT PLACED	
C540	NOT PLACED	
C541	NOT PLACED	
C542	NOT PLACED	
C543	NOT PLACED	
C544	2113743L09	470 pF, 10%
C545	2113743L09	470 pF, 10%
C546	2113743L09	470 pF, 10%
C547	2113743L09	470 pF, 10%

Circuit Ref	Motorola Part No.	Description
C548	NOT PLACED	
C549	2113743L09	470 pF, 10%
C550	2113743L09	470 pF, 10%
C551	2113743L09	470 pF, 10%
C552	2113743L09	470 pF, 10%
C553	2113743L09	470 pF, 10%
C555	2113743L09	470 pF, 10%
CR3301	4802245J42	Ring Quad Diode
CR3302	4805129M96	Dual Bond Diode
CR3303	4880154K03	Dual Diode MMBD353
CR501	4880107R01	Rectifier
CR503	4805729G49	Red / Yellow Diode
D3270	4862824C01	Varactor Diode
D3301	4802081B58	Dual Diode
D3302	4802081B58	Dual Diode
D3521	4880973Z02	PIN Diode
D3551	4880973Z02	PIN Diode
D3701	4802233J09	Triple Diode
D3702	4802233J09	Triple Diode
D3761	4862824C03	Varactor Diode
D3821	4805649Q13	Varactor Diode
D3831	4805649Q13	Varactor Diode
D3832	4862824C01	Varactor Diode
F501	6580542Z01	Fuse 3A
H3501	2680499Z01	Heat Spreader
J200	0905505Y04	Conn ZIF Horizontal
J3501	0985613Z01	RF Jack
J3502	0280519Z02	Antenna Nut (Ref: 0280519Z04)
L3200	2462587N68	1000 nH, 5%
L3201	NOT PLACED	
L3202	2462587N68	1000 nH, 5%
L3221	2462587N68	1000 nH, 5%
L3270	2462587T15	100 nH, 5%
L3271	2462587Q20	2200 nH, 20%
L3301	2462587T35	12 nH, 5%
L3303	2462587T35	12 nH, 5%
L3304	2462587T23	470 nH, 5%
L3305	2462587T35	12 nH, 5%
L3306	2462587T35	12 nH, 5%
L3308	2462587T34	10 nH, 5%
L3309	2462587N55	150 nH, 5%
L3312	2462587V28	33 nH, 5%
L3501	2413926H09	5.6 nH, 0.3 nH
L3503	2462587V32	68 nH, 5%
L3504	2462587N51	68 nH, 5%
L3511	2462587N44	18 nH, 5%
L3512	2479990B01	11.03 nH
L3513	2479990A02	7.66 nH
L3515	2479990C03	13.85 nH
L3518	NOT PLACED	

Circuit Ref	Motorola Part No.	Description
L3519	2484657R01	Inductor Bead Chip
L3521	2479990A02	7.66 nH
L3522	2479990E01	23.75 nH
L3523	2462587N68	1000 nH, 5%
L3531	2479990N01	43.67 nH
L3532	2479990N01	43.67 nH
L3538	2479990M01	30.54 nH
L3551	2479990N01	43.67 nH
L3552	2479990A02	7.66 nH
L3701	2462587Q42	390 nH, 10%
L3731	2462587Q20	2200 nH, 20%
L3801	2462587V34	100 nH, 5%
L3809	2462587V27	27 nH, 5%
L3811	2462587V34	100 nH, 5%
L3812	2462587V34	100 nH, 5%
L3813	2462587Q47	1000 nH, 10%
L3816	2462587V34	100 nH, 5%
L3821	2462587N50	56 nH, 5%
L3822	2462587N49	47 nH, 5%
L3823	2462587N49	47 nH, 5%
L3824	2462587N68	1000 nH, 5%
L3825	2462587V34	100 nH, 5%
L3826	2462587N68	1000 nH, 5%
L3831	2462587N50	56 nH, 5%
L3832	2462587N51	68 nH, 5%
L3833	2462587N50	56 nH, 5%
L3834	2462587N68	1000 nH, 5%
L505	2462587Q42	390 nH, 10%
PB501	4070354A01	Light Touch Switch
PB502	4070354A01	Light Touch Switch
PB504	4070354A01	Light Touch Switch
PB505	4070354A01	Light Touch Switch
Q3200	4813827A07	Transistor NPN MMBR941
Q3201	4880214G02	Transistor MMBT3904
Q3202	4880214G02	Transistor MMBT3904
Q3270	4805218N63	RF Transistor BFQ67W
Q3301	4880214G02	Transistor MMBT3904
Q3302	4813827A07	Transistor NPN MMBR941
Q3501	4813828A08	Transistor 8W 175MHz
Q3561	4813824A17	XSTR PNP 40V
Q3721	4809939C05	Transistor Dual NPN / PNP
Q3801	4813827A07	Transistor NPN MMBR941
Q502	5180159R01	Dual Transistor NPN
Q505	4880214G02	Transistor MMBT3904
R3200	0662057M54	150, 5%
R3201	0662057M82	2200, 5%
R3202	0662057M90	4700, 5%
R3203	0662057M98	10 k, 5%
R3204	0662057M26	10, 5%
R3205	0662057M74	1000, 5%
R3206	0662057N23	100 k, 5%

Circuit Ref	Motorola Part No.	Description
R3207	0662057N13	39 k, 5%
R3208	0662057M50	100, 5%
R3209	0662057M74	1000, 5%
R3210	0662057M82	2200, 5%
R3211	0662057M82	2200, 5%
R3212	0662057M90	4700, 5%
R3213	0662057M82	2200, 5%
R3214	0662057M34	22, 5%
R3218	NOT PLACED	
R3219	0662057M50	100, 5%
R3220	0662057M90	4700, 5%
R3221	0662057M50	100, 5%
R3222	NOT PLACED	
R3223	NOT PLACED	
R3224	0662057M26	10, 5%
R3225	0662057M74	1000, 5%
R3226	0662057M26	10, 5%
R3270	0662057M74	1000, 5%
R3271	0662057M42	47, 5%
R3272	0662057N15	47 k, 5%
R3273	0662057N15	47 k, 5%
R3274	0662057M83	2400, 5%
R3275	0662057M74	1000, 5%
R3276	0662057N30	200 k, 5%
R3301	NOT PLACED	
R3303	0662057N23	100 k, 5%
R3304	0662057N23	100 k, 5%
R3305	0662057N19	68 k, 5%
R3306	0662057M82	2200, 5%
R3307	0662057N11	33 k, 5%
R3308	0662057M78	1500, 5%
R3309	0662057M92	5600, 5%
R3310	0662057M98	10 k, 5%
R3311	0662057M26	10, 5%
R3312	0662057M38	33, 5%
R3313	0662057M34	22, 5%
R3314	0662057M26	10, 5%
R3315	0662057M62	330, 5%
R3316	0662057M66	470, 5%
R3317	0662057N23	100 k, 5%
R3318	0662057M66	470, 5%
R3319	NOT PLACED	
R3320	NOT PLACED	
R3321	0662057M54	150, 5%
R3322	0662057M58	220, 5%
R3323	0662057M32	18, 5%
R3324	0662057M58	220, 5%
R3501	0662057M61	300, 5%
R3502	0662057M32	18, 5%
R3503	0662057M61	300, 5%
R3505	0662057M62	330, 5%

Circuit Ref	Motorola Part No.	Description
R3506	0662057B62	3.9, 5%
R3507	0662057B62	3.9, 5%
R3512	NOT PLACED	
R3513	NOT PLACED	
R3519	0680539Z01	Power Metal Strip Resistor
R3541	0662057N13	39 k, 5%
R3542	0662057M92	5600, 5%
R3543	0662057M50	100, 5%
R3544	0662057A25	100, 5%
R3545	0662057A25	100, 5%
R3546	0662057N01	12 k, 5%
R3547	0662057N11	33 k, 5%
R3548	0662057N07	22 k, 5%
R3551	0662057M40	39, 5%
R3561	0662057N01	12 k, 5%
R3562	0662057N11	33 k, 5%
R3563	0662057N33	270 k, 5%
R3564	0662057N35	330 k, 5%
R3565	NOT PLACED	
R3566	NOT PLACED	
R3569	0662057M92	5600, 5%
R3570	0662057M98	10 k, 5%
R3571	0662057A27	120, 5%
R3572	0662057A27	120, 5%
R3573	0662057A27	120, 5%
R3701	0662057M50	100, 5%
R3702	NOT PLACED	
R3703	0662057M54	150, 5%
R3704	0662057M54	150, 5%
R3705	0662057N11	33 k, 5%
R3721	0662057M66	470, 5%
R3722	0662057M74	1000, 5%
R3723	0662057M50	100, 5%
R3726	NOT PLACED	
R3727	0662057N23	100 k, 5%
R3741	0662057M50	100, 5%
R3751	0662057N30	200 k, 5%
R3752	0662057N35	330 k, 5%
R3760	NOT PLACED	
R3761	0662057N15	47 k, 5%
R3762	NOT PLACED	
R3763	NOT PLACED	
R3801	NOT PLACED	
R3802	0662057M50	100, 5%
R3803	0662057M58	220, 5%
R3804	0662057M98	10 k, 5%
R3805	0662057N08	24 k, 5%
R3806	0662057M34	22, 5%
R3807	NOT PLACED	
R3808	0662057M26	10, 5%
R3811	0662057M50	100, 5%

Circuit Ref	Motorola Part No.	Description
R3812	NOT PLACED	
R3816	0662057M74	1000, 5%
R3817	0662057M01	0, 5%
R3818	NOT PLACED	
R3821	0662057M58	220, 5%
R3822	0662057M42	47, 5%
R3823	0662057N11	33 k, 5%
R3824	0662057N07	22 k, 5%
R3825	0662057M38	33, 5%
R3826	0662057M32	18, 5%
R3828	0662057M50	100, 5%
R3829	0662057M01	0, 5%
R3830	NOT PLACED	
R3831	0662057M98	10 k, 5%
R3832	0662057N01	12 k, 5%
R3833	0662057M58	220, 5%
R3834	0662057M42	47, 5%
R3835	0662057N15	47 k, 5%
R3836	0662057M98	10 k, 5%
R501	0662057M70	680, 5%
R502	0662057M56	180, 5%
R505	0662057M98	10 k, 5%
R506	0662057N15	47 k, 5%
R509	0662057M01	0, 5% (not used in GP328 Plus)
RT3301	NOT PLACED	
S501	4080710Z01	Channel Switch (Ref: 4080710Z09)
	4080710Z05	Channel Switch (used in PMUD1892_ only) (Ref: 4080710Z12)
S502	1880619Z02	Potentiometer (Volume)
SH3201	2602023X08	Shield Diplexer
SH3202	2686081B02	Shield, for GSM Placement
SH3203	2686081B03	Shield, for GSM Placement
SH3301	2686081B01	Shield, for GSM Placement
SH3302	2686081B05	Shield, for GSM Placement
SH3303	2686081B06	Shield, for GSM Placement
SH3501	2686081B03	Shield, for GSM Placement
SH3502	2686081B04	Shield, for GSM Placement
SH3701	2680511Z01	Shield, Synthesizer
SH3702	2680511Z01	Shield, Synthesizer
SH3801	2680513Z01	Shield, VCO Top
SH3802	2680514Z01	Shield, VCO Bottom / LVZIF
T3301	2580541Z02	Balun Transformer
T3302	2580541Z02	Balun Transformer
TP3301	NOT PLACED	
TP3502	NOT PLACED	
TP3701	NOT PLACED	
TP3702	NOT PLACED	
U3201	5102463J58	3.3V Regulator

Circuit Ref	Motorola Part No.	Description
U3220	5109632D83	LVZIF
U3501	5185130C65	LDMOS Driver
U3502	5185765B26	PCIC
U3503	5185963A15	Temperature Sensor IC
U3701	5185963A27	LVFRACN
U3711	5105739X05	5V Regulator
U3801	5105750U54	VCO Buffer
VR3501	4880140L17	12V Zener Diode
VR439	4880140L17	12V Zener Diode
VR440	NOT PLACED	
VR441	NOT PLACED	
VR444	NOT PLACED	
VR501	4802245J73	6.8V Zener Diode
VR506	4802245J73	6.8V Zener Diode
Y3200	9186153B01	X'tal Filter
Y3761	**4805875Z04	Crystal 16.8 MHz
Y3762	NOT PLACED	
	8404055G05	RF PCB
	8404055G06	RF PCB
	8404055G07	RF PCB
	8404055G09	RF PCB

* Motorola Depot Servicing only

** Not Serviceable

THIS PAGE INTENTIONALLY LEFT BLANK

9.0 Troubleshooting Charts

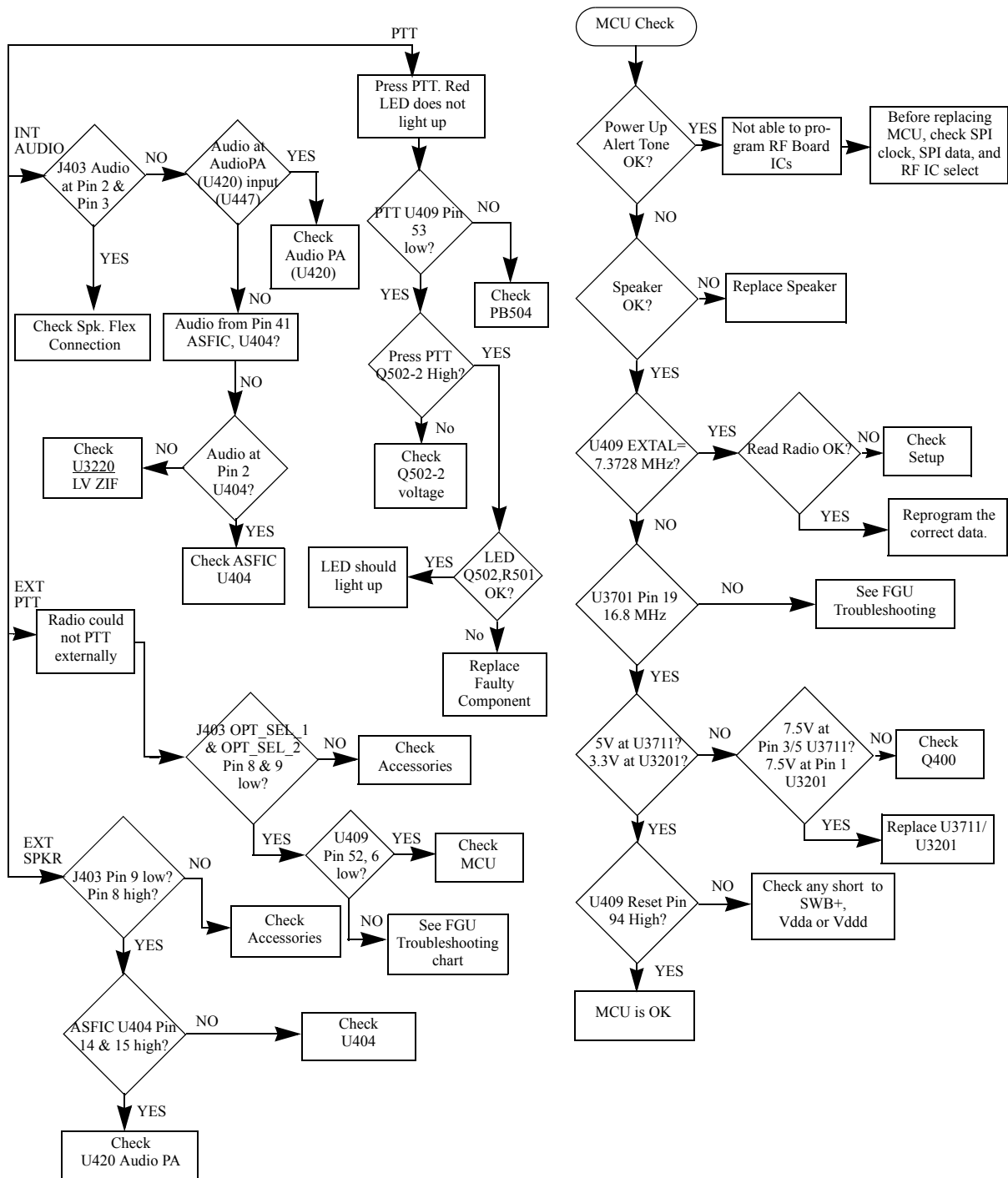

Troubleshooting Flow Chart for Controller

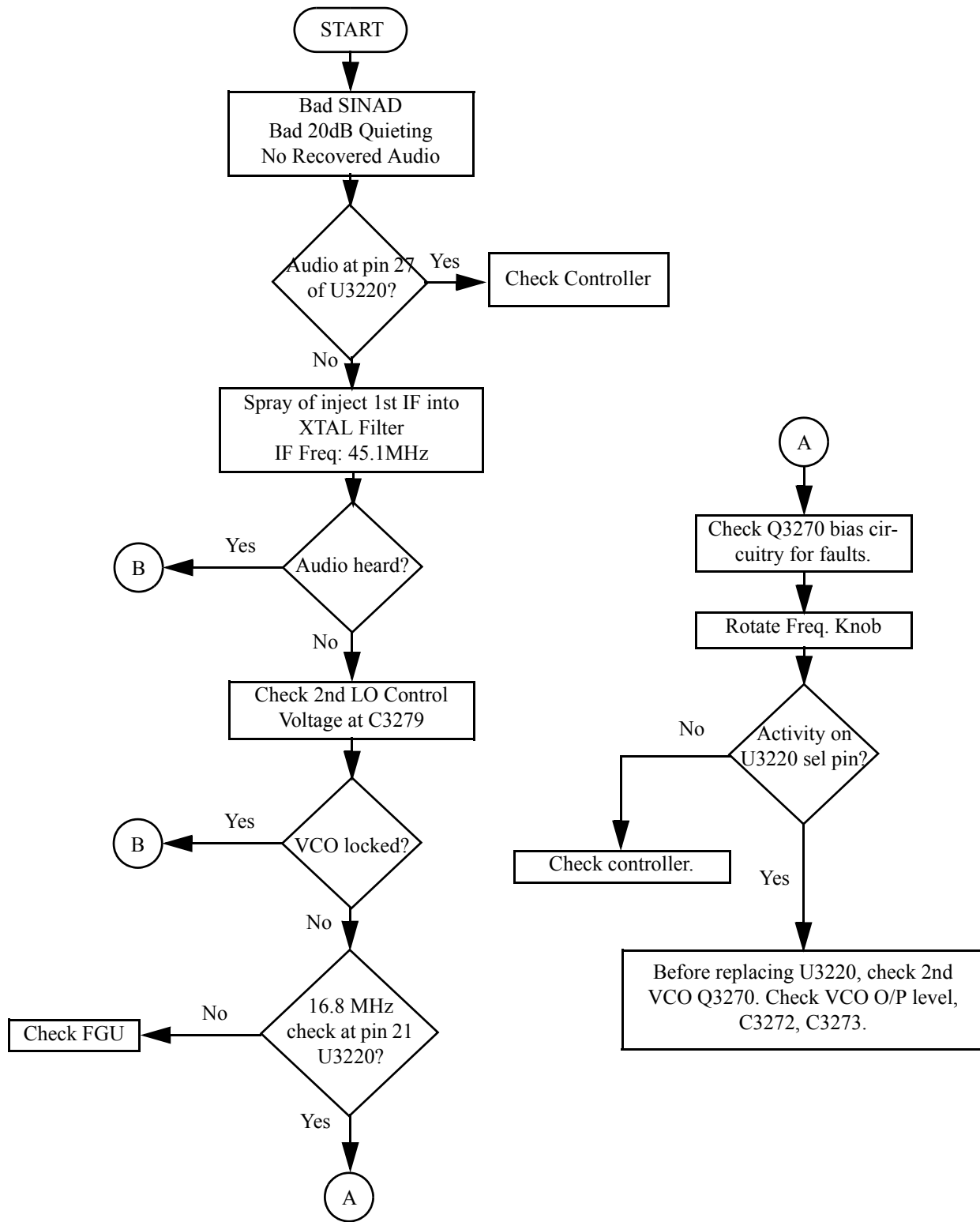

Troubleshooting Flow Chart for Receiver (Sheet 1 of 2)

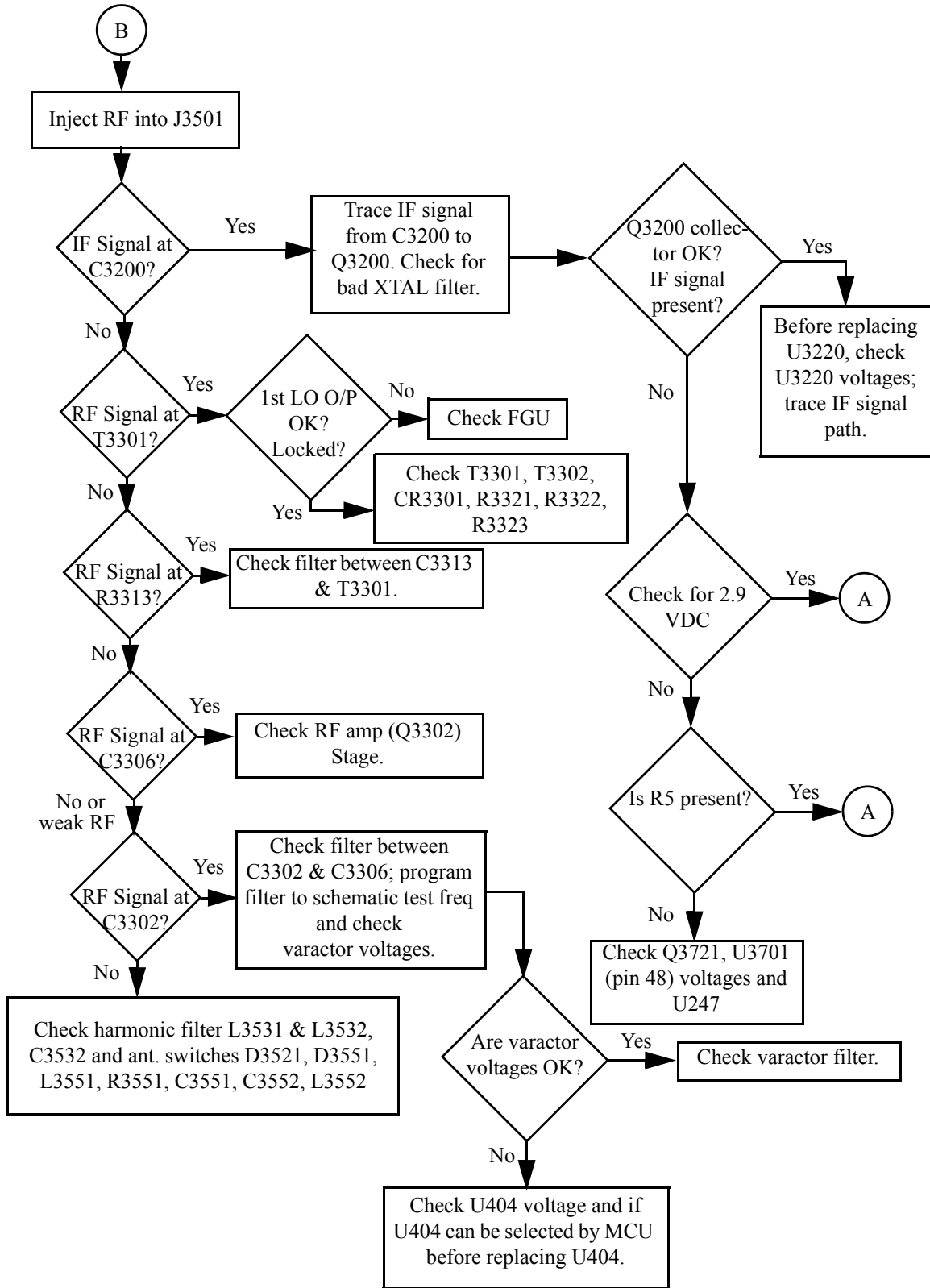

Troubleshooting Flow Chart for Receiver (Sheet 2 of 2)

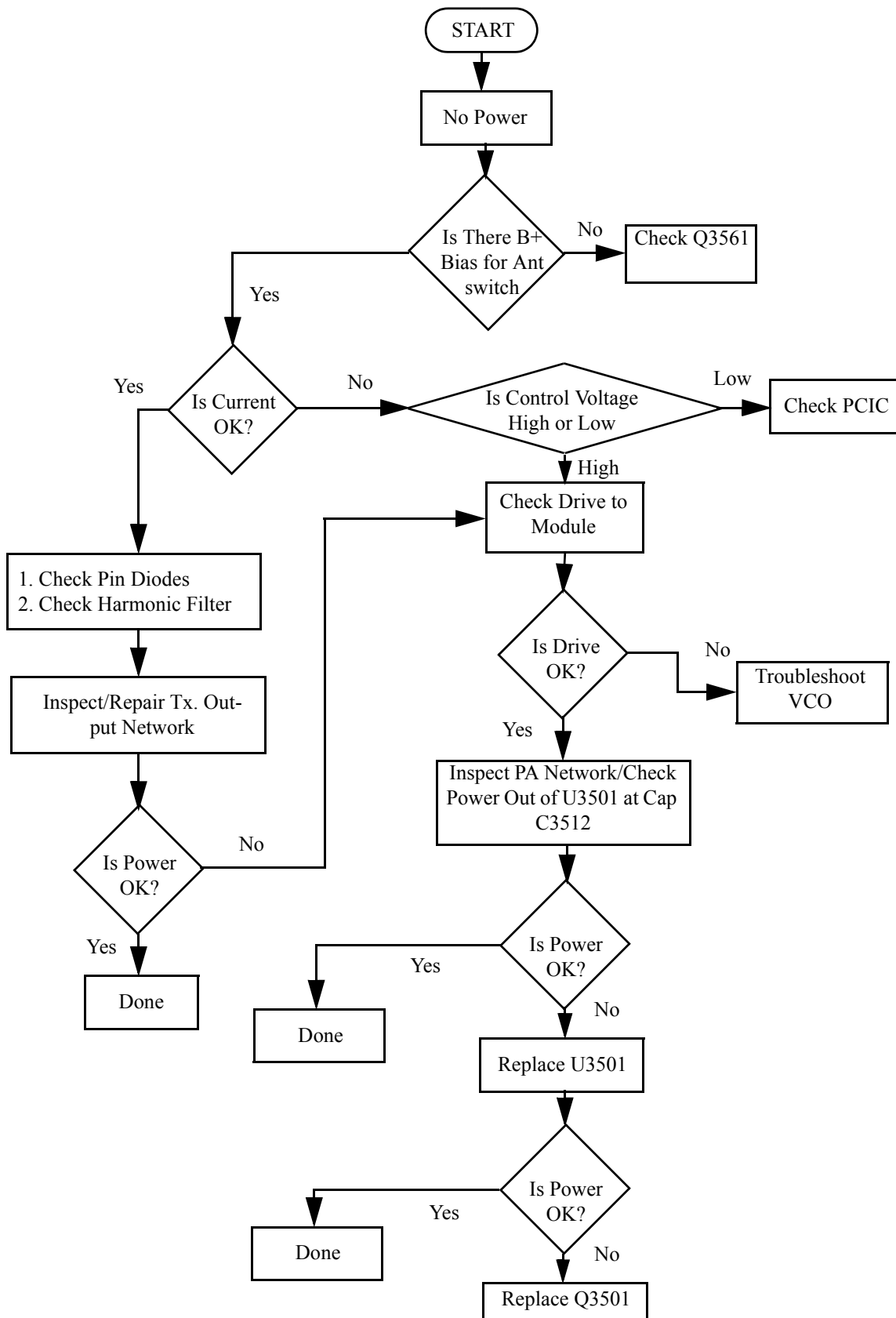

Troubleshooting Flow Chart for Transmitter

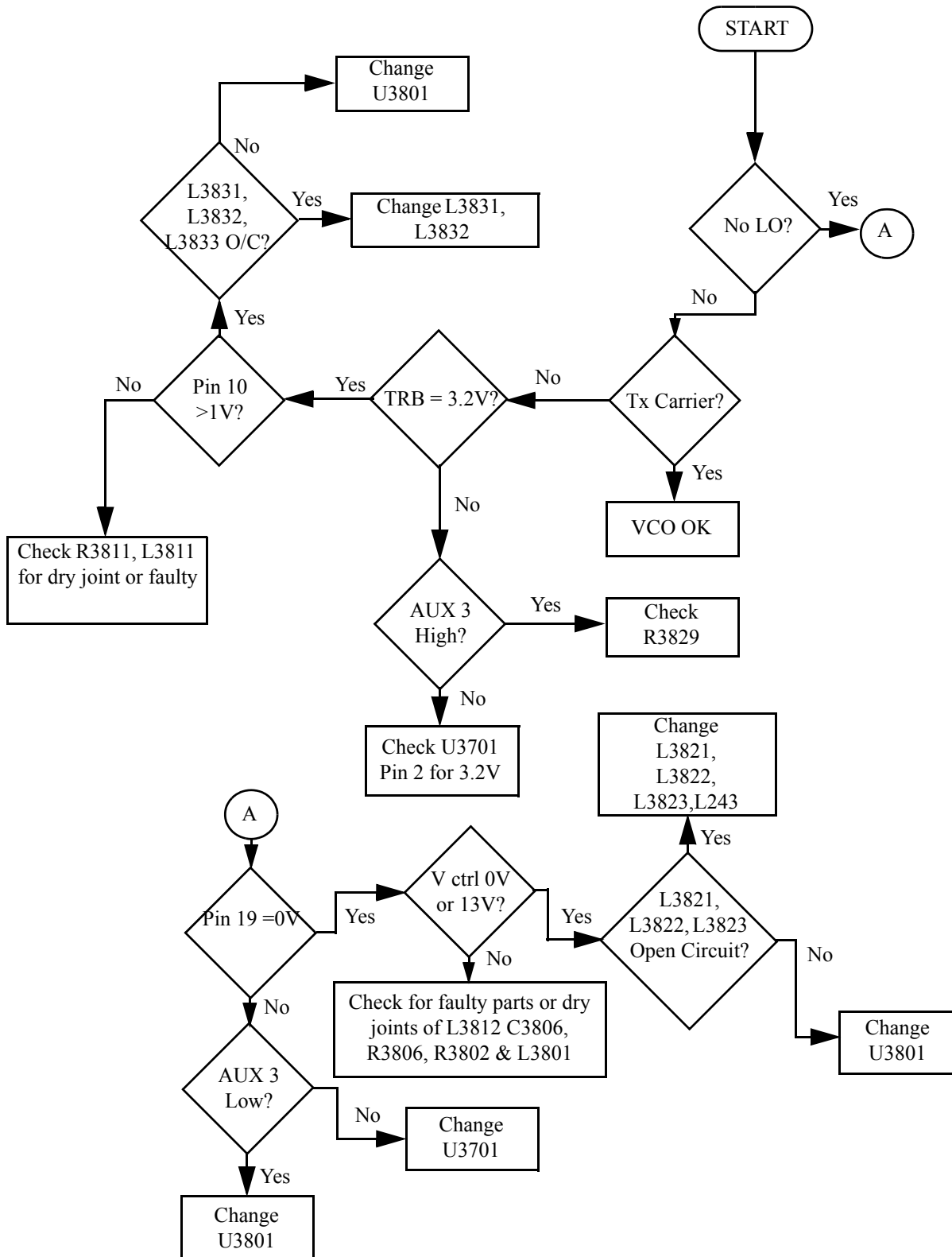

Troubleshooting Flow Chart for VCO

Section 5B

MODEL CHART AND TEST SPECIFICATIONS (403-470 MHZ)

1.0 Model Chart

GP Series, UHF Band 1, 403-470 MHz					
Model				Description	
			AZH38RDC9AA2		GP328 Plus 403-470 MHz 4W 4 CH
			AZH38RDC9AA3		GP328 Plus 403-470 MHz 4W 16 CH
			AZH38RDH9AA6		GP338 Plus 403-470 MHz 4W 128 CH
			AZH38RDH9DU6		GP338 XLS 403-470 MHz 4W 160 CH
				Item	Description
X				PMUE2048_	GP328 Plus Super Tanapa 403-470 MHz 4W 4CH
	X			PMUE1699_	GP328 Plus Super Tanapa 403-470 MHz 4W 16CH
		X		PMUE1700_	GP338 Plus Super Tanapa 403-470 MHz 4W 128CH
			X	PMUE1876_	GP338 XLS Super Tanapa 403-470 MHz 4W 160CH
X				PMUE2050_	GP328 Plus Tanapa 403-470 MHz 4W 4CH
	X			PMUE1703_	GP328 Plus Tanapa 403-470 MHz 4W 16CH
		X		PMUE1704_	GP338 Plus Tanapa 403-470 MHz 4W 128CH
			X	PMUE1878_	GP338 XLS Tanapa 403-470 MHz 4W 160CH
X				PMHE4026_	GP328 Plus B/C Kit 403-470 MHz 4W 4CH
	X			JMHE4001_	GP328 Plus B/C Kit 403-470 MHz 4W 16CH
		X		PMHE4010_	GP338 Plus B/C Kit 403-470 MHz 4W 128CH
			X	PMHE4020_	GP338 XLS B/C Kit 403-470 MHz 4W 160CH
X				PMHE4024_	GP328 Plus Front Housing Kit 4CH
	X			PMHE4000_	GP328 Plus Front Housing Kit 16CH
		X		PMHE4001_	GP338 Plus Front Housing Kit 128CH
			X	PMHE4018_	GP338 XLS Front Housing Kit 160CH
X	X	X	X	NAE6483_	Monopole (Whip) antenna (403-520 MHz)
X	X	X	X	PMAE4002_	UHF 9 cm antenna (403-433 MHz) Stubby
X	X	X	X	PMAE4003_	UHF 9 cm antenna (430-470 MHz)
X	X			6804022G48	GP328 Plus User Guide
		X		6804112J64	GP338 Plus User Guide
			X	6804114J01	GP338 XLS User Guide

x = Indicates one of each is required.

2.0 Specifications (for GP328 Plus)

General

	UHF	
Frequency:	403-470 MHz	
Channel Capacity:	GP328 Plus : 4/16 Channels	
Power Supply:	7.5 Volts \pm 20%	
Dimensions with Standard High Capacity Lithium Battery:	101.5mm x 55.5mm x 30.5mm	
Dimensions with Ultra High Capacity Lithium Battery:	101mm x 55.5mm x 35.5mm	
Weight: with Standard High Capacity Lithium Battery:	250 g	
Weight: with Ultra High Capacity Lithium Battery:	270 g	
Average Battery Life @ (5-5-90 Duty Cycle) Standard High Capacity Lithium Battery: Ultra High Capacity Lithium Battery:	Low Power	High Power
	>10 hrs	>7 hrs
	>14 hrs	>10 hrs
Sealing:	Meets MIL-STD-810-C, D & E and IPX4	
Shock:	Meets MIL-STD-810-C,D & E and TIA/EIA 603	
Vibration:	Meets MIL-STD-810-C,D & E and TIA/EIA 603	
Dust:	Meets MIL-STD-810-C,D & E and IP5X	
Humidity:	Meets MIL-STD-810-C,D & E and TIA/EIA 603	
FCC ID	AZ489FT4844	

Transmitter

	UHF	
RF Output Li Ion @ 7.5V:	Low 1W	High 4W
Frequency	403-470 MHz	
Channel Spacing	12.5/20/25 kHz	
Freq. Stability (-30°C to +60°C)	0.00025%	
Spurs/Harmonics:	-36 dBm < 1 GHz -30 dBm > 1 GHz	
Audio Response: (from 6 dB/oct. Pre-Emphasis, 300 to 3000Hz)	+1, -3 dB	
Audio Distortion: @ 1000 Hz, 60% Rated Max. Dev.	<5%	
FM Noise:	-40 dB	

Receiver

	UHF 12.5kHz	UHF 20/25kHz
Frequency:	403-470MHz	403-470MHz
Sensitivity 12dB EIA SINAD:	0.35 μ V	0.35 μ V
Adjacent Channel Selectivity ETS	-60 dB	-70 dB
Intermodulation ETS	-65 dB	-65 dB
Freq. Stability (-30°C to +60°C):	0.00025%	0.00025%
Spur Rejection:	-70 dB	-70 dB
Image Rejection:	-70 dB	-70 dB
Audio Output @ <5% Distortion	500 mW	500 mW

All specifications are subject to change without notice.

3.0 Specifications (for GP338 Plus/GP338 XLS)

General

	UHF	
Frequency:	403-470 MHz	
Channel Capacity:	GP338 Plus 128 Channels/GP338 XLS 160 Channels	
Power Supply:	7.5 Volts ±20%	
Dimensions with Standard High Capacity Lithium Battery:	101.5mm x 55.5mm x 33.0mm	
	with Ultra High Capacity Lithium Battery: 101mm x 55.5mm x 38.0mm	
Weight: with Standard High Capacity Lithium Battery:	265 g	
	with Ultra High Capacity Lithium Battery: 285 g	
Average Battery Life @ (5-5-90 Duty Cycle) Standard High Capacity Lithium Battery: Ultra High Capacity Lithium Battery:	Low Power	High Power
	>10 hrs	>7 hrs
	>14 hrs	>10 hrs
Sealing:	Meets MIL-STD-810-C,D & E and IPX4	
Shock:	Meets MIL-STD-810-C,D & E and TIA/EIA 603	
Vibration:	Meets MIL-STD-810-C,D & E and TIA/EIA 603	
Dust:	Meets MIL-STD-810-C,D & E and IP5X	
Humidity:	Meets MIL-STD-810-C,D & E and TIA/EIA 603	
FCC ID	AZ489FT4844	

Transmitter

	UHF	
RF Output Li Ion @ 7.5V:	Low 1W	High 4W
Frequency	403-470 MHz	
Channel Spacing	12.5/20/25 kHz	
Freq. Stability (-30°C to +60°C)	0.00025%	
Spurs/Harmonics:	-36 dBm < 1 GHz -30 dBm > 1 GHz	
Audio Response: (from 6 dB/oct. Pre-Emphasis, 300 to 3000Hz)	+1, -3 dB	
Audio Distortion: @ 1000 Hz, 60% Rated Max. Dev.	<5%	
FM Noise:	-40 dB	

Receiver

	UHF 12.5kHz	UHF 20/ 25kHz
Frequency:	403-470MHz	403-470MHz
Sensitivity 12dB EIA SINAD:	0.35 µV	0.35 µV
Adjacent Channel Selectivity ETS	-60 dB	-70 dB
Intermodulation ETS	-65 dB	-65 dB
Freq. Stability (-30°C to +60°C):	0.00025%	0.00025%
Spur Rejection:	-70 dB	-70 dB
Image Rejection:	-70 dB	-70 dB
Audio Output @ <5% Distortion	500 mW	500 mW

All specifications are subject to change without notice.

4.0 Transmitter

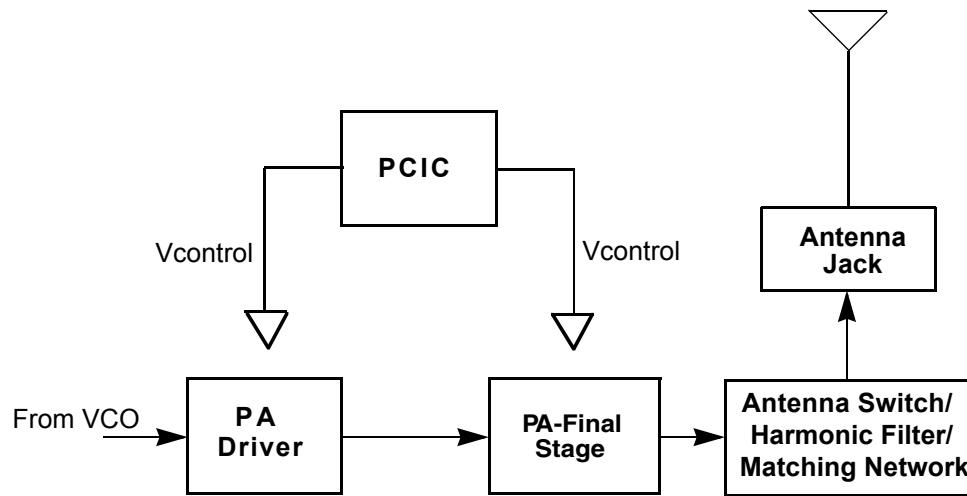

Figure 5-1: Transmitter Block Diagram

4.1 General

(Refer to Figure 5-1)

The UHF transmitter contains five basic circuits:

1. Power Amplifier
2. Antenna Switch
3. Harmonic Filter
4. Antenna Matching Network
5. Power Control Integrated Circuit (PCIC).

4.1.1 Power Amplifier

The power amplifier consists of two devices:

1. 9Z67 LDMOS driver IC (U101) and
2. PRF1507 LDMOS PA (Q110).

The 9Z67 LDMOS driver IC contains a 2 stage amplification with a supply voltage of 7.3V.

This RF power amplifier is capable of supplying an output power of 0.3W (pin 6 and 7) with an input signal of 2mW (3dBm) (pin16). The current drain would typically be 160mA while operating in the frequency range of 403-470MHz.

The PRF1507 LDMOS PA is capable of supplying an output power of 7W with an input signal of 0.3W. The current drain would typically be 1300mA while operating in the frequency range of 403-470MHz. The power output can be varied by changing the biasing voltage.

4.1.2 Antenna Switch

The antenna switch circuit consists of two PIN diodes (CR101 and CR102), a pi network (C107, L104 and C106), and two current limiting resistors (R101, R170). In the transmit mode, B+ at PCIC (U102) pin 23 will go low and turn on Q111 where a B+ bias is applied to the antenna switch circuit to bias the diodes "on". The shunt diode (CR102) shorts out the receiver port, and the pi network, which operates as a quarter wave transmission line, transforms the low impedance of the shunt diode to a high impedance at the input of the harmonic filter. In the receive mode, the diodes are both off, and hence, there exists a low attenuation path between the antenna and receiver ports.

4.1.3 Harmonic Filter

The harmonic filter consists of C104, L102, C103, L101 and C102. The design of the harmonic filter for UHF is that of a modified Zolotarev design. It has been optimized for efficiency of the power module. This type of filter has the advantage that it can give a greater attenuation in the stop-band for a given ripple level. The harmonic filter insertion loss is typically less than 1.2dB.

4.1.4 Antenna Matching Network

A matching network which is made up of L116 is used to match the antenna's impedance to the harmonic filter. This will optimize the performance of the transmitter and receiver into an antenna.

4.1.5 Power Control Integrated Circuit (PCIC)

The transmitter uses the Power Control IC (PCIC), U102 to regulate the power output of the radio. The current to the final stage of the power module is supplied through R101, which provides a voltage proportional to the current drain. This voltage is then fed back to the Automatic Level Control (ALC) within the PCIC to regulate the output power of the transmitter.

The PCIC has internal digital to analog converters (DACs) which provide the reference voltage of the control loop. The reference voltage level is programmable through the SPI line of the PCIC.

There are resistors and integrators within the PCIC, and external capacitors (C133, C134 and C135) in controlling the transmitter rising and falling time. These are necessary in reducing the power splatter into adjacent channels.

CR105 and its associated components are part of the temperature cut back circuitry. It senses the printed circuit board temperature around the transmitter circuits and output a DC voltage to the PCIC. If the DC voltage produced exceeds the set threshold in the PCIC, the transmitter output power will be reduced so as to reduce the transmitter temperature.

5.0 Receiver

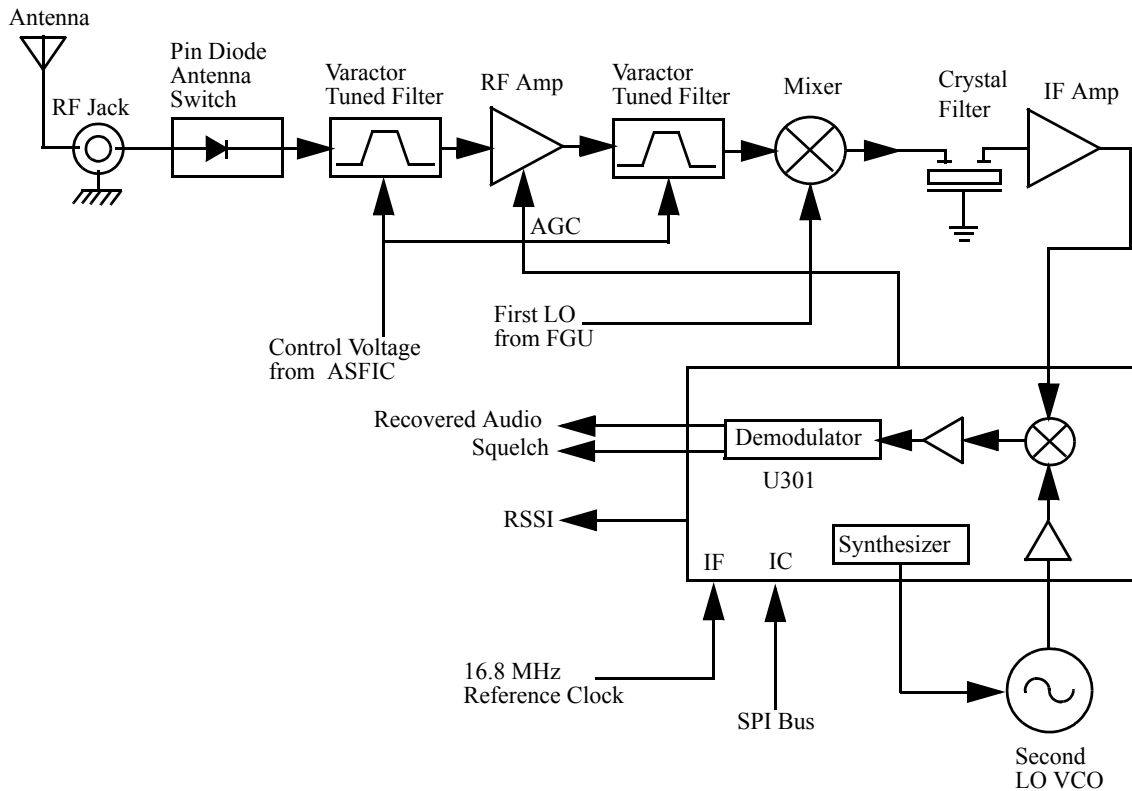

Figure 5-2: UHF Receiver Block Diagram

5.1 Receiver Front-End

(Refer to *UHF Receiver Front End Schematic Diagram* on page 5B-21 and *UHF Transmitter Schematic Diagram* on page 5B-25)

The RF signal is received by the antenna and applied to a low-pass filter. For UHF, the filter consists of L101, L102, C102, C103, C104. The filtered RF signal is passed through the antenna switch. The antenna switch circuit consists of two PIN diodes (CR101 and CR102) and a pi network (C106, L104 and C107). The signal is then applied to a varactor tuned bandpass filter. The UHF bandpass filter comprises of L301, L302, C302, C303, C304, CR301 and CR302. The bandpass filter is tuned by applying a control voltage to the varactor diodes (CR301 and CR302) in the filter.

The bandpass filter is electronically tuned by the DACRx from IC404 which is controlled by the microprocessor. Depending on the carrier frequency, the DACRx will supply the tuned voltage to the varactor diodes in the filter. Wideband operation of the filter is achieved by shifting the bandpass filter across the band.

The output of the bandpass filter is coupled to the RF amplifier transistor Q301 via C307. After being amplified by the RF amplifier, the RF signal is further filtered by a second varactor tuned bandpass filter, consisting of L306, L307, C313, C317, CR304 and CR305.

Both the pre and post-RF amplifier varactor tuned filters have similar responses. The 3 dB bandwidth of the filter is about 50 MHz. This enables the filters to be electronically controlled by using a single control voltage which is DACRx.

The output of the post-RF amplifier filter which is connected to the passive double balanced mixer consists of T301, T302 and CR306. Matching of the filter to the mixer is provided by C381. After mixing with the first LO signal from the voltage controlled oscillator (VCO) using low side injection, the RF signal is down-converted to the 45.1 MHz IF signal.

The IF signal coming out of the mixer is transferred to the crystal filter (FL301) through a resistor pad and a diplexer (C322 and L310). Matching to the input of the crystal filter is provided by C324 and L311. The crystal filter provides the necessary selectivity and intermodulation protection.

5.2 Receiver Back-End

(Refer to *UHF Receiver Back End Schematic Diagram* on page 5B-22)

The output of crystal filter FL301 is matched to the input of IF amplifier transistor Q302 by components R352 and C325. Voltage supply to the IF amplifier is taken from the receive 5 volts (R5). The IF amplifier provides a gain of about 7dB. The amplified IF signal is then coupled into U301 (pin 3) via C330, C338 and L330 which provides the matching for the IF amplifier and U301.

The IF signal applied to pin 3 of U301 is amplified, down-converted, filtered, and demodulated, to produce the recovered audio at pin 27 of U301. This IF IC is electronically programmable, and the amount of filtering (which is dependent on the radio channel spacing) is controlled by the microprocessor. Additional filtering, once externally provided by the conventional ceramic filters, is replaced by internal filters in the IF module (U301).

The IF IC uses a type of direct conversion process, whereby the externally generated second LO frequency is divided by two in U301 so that it is very close to the first IF frequency. The IF IC (U301) synthesizes the second LO and phase-locks the VCO to track the first IF frequency. The second LO is designed to oscillate at twice the first IF frequency because of the divide-by-two function in the IF IC.

In the absence of an IF signal, the VCO will “search” for a frequency, or its frequency will vary close to twice the IF frequency. When an IF signal is received, the VCO will lock onto the IF signal. The second LO/VCO is a Colpitts oscillator built around transistor Q320. The VCO has a varactor diode, CR310, to adjust the VCO frequency. The control signal for the varactor is derived from a loop filter consisting of C362, C363, C364, R320 and R321.

The IF IC (U301) also performs several other functions. It provides a received signal-strength indicator (RSSI) and a squelch output. The RSSI is a dc voltage monitored by the microprocessor, and used as a peak indicator during the bench tuning of the receiver front-end varactor filter. The RSSI voltage is also used to control the automatic gain control (AGC) circuit at the front-end.

The demodulated signal on pin 27 of U301 is also used for squelch control. The signal is routed to U404 (ASFIC) where squelch signal shaping and detection takes place. The demodulated audio signal is also routed to U404 for processing before going to the audio amplifier for amplification.

5.3 Automatic Gain Control Circuit

(Refer to *UHF Receiver Front End Schematic Diagram* on page 5B-21)

The front end automatic gain control circuit is to provide automatic gain reduction of the front end RF amplifier via feedback. This action is necessary to prevent overloading of back end circuits. This is achieved by drawing some of the output power from the RF amplifier's output. At high radio frequencies, capacitor C331 provides the low impedance path to ground for this purpose. CR308 is a PIN diode used for switching the path on or off. A certain amount of forward biasing current is needed to turn the PIN diode on. Transistor Q315 provides this current where upon saturation, current will flow via R347, PIN diode, collector and emitter of Q315 and R319 before going to ground. Q315 is an NPN transistor used for switching here. Maximum current flowing through the PIN is mainly limited by the resistor R319.

Radio signal strength indicator, RSSI, a voltage signal, is used to drive Q315 to saturation hence turning it on. RSSI is produced by U301 and is proportional to the gain of the RF amplifier and the input RF signal power to the radio.

Resistor network at the input to the base of Q315 is scaled to turn on Q315, hence activating the AGC, at certain RSSI levels. In order to turn on Q315, the voltage across the transistor's base to ground must be greater or equal to the voltage across R319, plus the base-emitter voltage (V_{be}) present at Q315. The resistor network with thermistor RT300 is capable of providing temperature compensation to the AGC circuit, as RSSI generated by U301 is lower at cold temperatures compared to normal operation at room temperature. Resistor R300 and capacitor C397 form an R-C network used to dampen any transient instability while the AGC is turning on.

6.0 Frequency Generation Circuitry

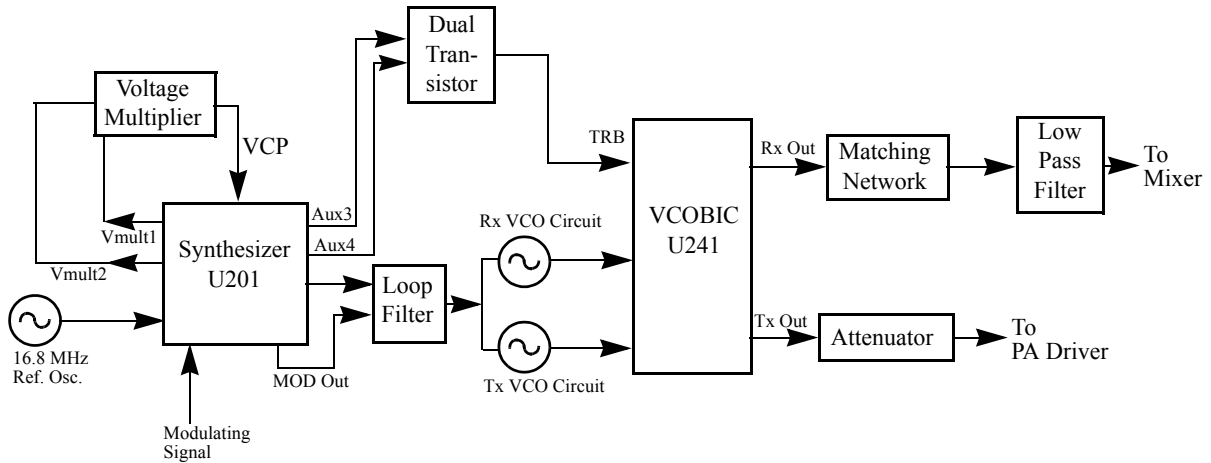

Figure 5-3: Frequency Generation Unit Block Diagram

The Frequency Generation Circuitry is composed of two main ICs, the Fractional-N synthesizer (U201), and the VCO/Buffer IC (U241). Designed in conjunction to maximize compatibility, the two ICs provide many of the functions that normally would require additional circuitry. The synthesizer block diagram illustrates the interconnect and support circuitry used in the region. Refer to the relevant schematics for the reference designators.

The synthesizer is powered by regulated 5V and 3.3V which come from U247 and U248 respectively. The synthesizer in turn generates a superfiltered 4.5V which powers U241.

In addition to the VCO, the synthesizer must interface with the logic and ASFIC circuitry.

Programming for the synthesizer is accomplished through the data, clock and chip select lines from the microprocessor. A 3.3V dc signal from synthesizer lock detect line indicates to the microprocessor that the synthesizer is locked.

Transmit modulation from the ASFIC is supplied to pin10 of U201. Internally the audio is digitized by the Fractional-N and applied to the loop divider to provide the low-port modulation. The audio runs through an internal attenuator for modulation balancing purposes before going out to the VCO.

6.1 Synthesizer

(Refer to *UHF Synthesizer Schematic Diagram* on page 5B-23)

The Fractional-N Synthesizer uses a 16.8MHz crystal (FL201) to provide a reference for the system. The LVFractN IC (U201) further divides this to 2.1MHz, 2.225MHz, and 2.4MHz as reference frequencies. Together with C206, C207, C208, R204 and CR203, they build up the reference oscillator which is capable of 2.5ppm stability over temperatures of -30 to 85°C. It also provides 16.8MHz at pin 19 of U201 to be used by ASFIC and LVZIF.

The loop filter which consist of C231, C232, C233, R231, R232 and R233 provides the necessary dc steering voltage for the VCO and determines the amount of noise and spur passing through.

In achieving fast locking for the synthesizer, an internal adapt charge pump provides higher current at pin 45 of U201 to put synthesizer within the lock range. The required frequency is then locked by normal mode charge pump at pin 43.

Both the normal and adapt charge pumps get their supply from the capacitive voltage multiplier which is made up of C258, C259, C228, triple diode CR201 and level shifters U210 and U211. Two 3.3V square waves (180 deg out of phase) are first shifted to 5V, then along with regulated 5V, put through arrays of diodes and capacitors to build up 13.3V at pin 47 of U201.

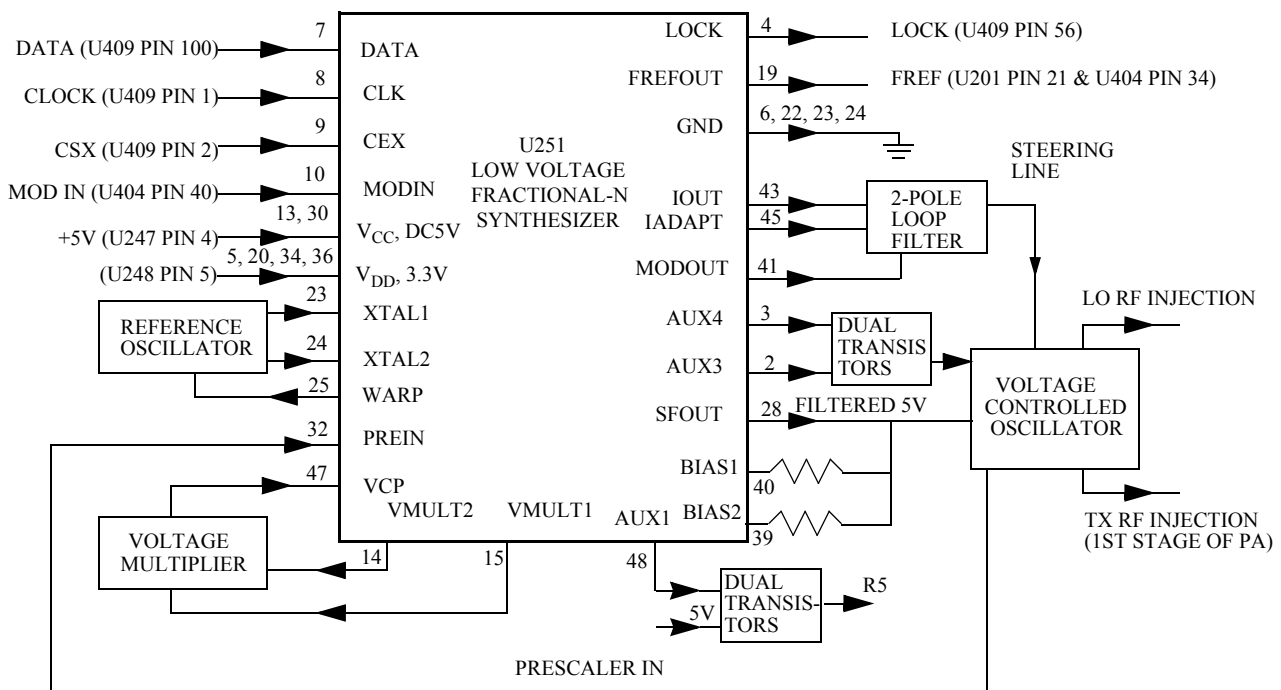

Figure 5-4: Synthesizer Block Diagram

6.2 VCO - Voltage Controlled Oscillator

(Refer to *UHF Voltage Controlled Oscillator Schematic Diagram* on page 5B-24)

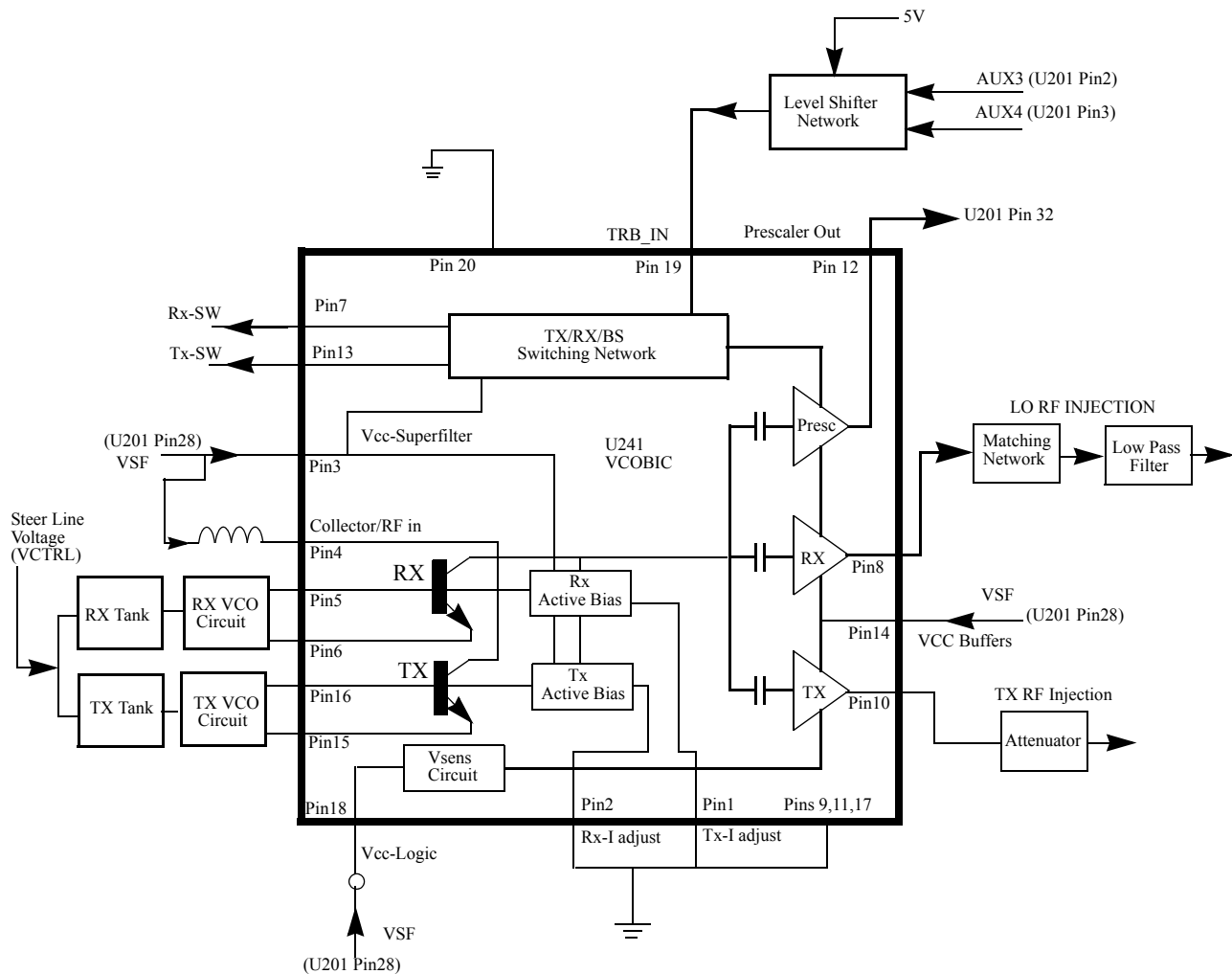

Figure 5-5: VCO Block Diagram

The VCOBIC (U241) in conjunction with the Fractional-N synthesizer (U201) generates RF in both the receive and the transmit modes of operation. The TRB line (U241 pin 19) determines which oscillator and buffer will be enabled. A sample of the RF signal from the enabled oscillator is routed from U241 pin 12, through a low pass filter, to the prescaler input (U201 pin 32). After frequency comparison in the synthesizer, a resultant CONTROL VOLTAGE is received at the VCO. This voltage is a DC voltage between 3.5V and 9.5V when the PLL is locked on frequency.

The VCOBIC(U241) is operated at 4.54 V (VSF) and Fractional-N synthesizer (U201) at 3.3V. This difference in operating voltage requires a level shifter consisting of Q260 and Q261 on the TRB line. The operation logic is shown in Table 5-1.

Table 5-1: Level Shifter Logic

Desired Mode	AUX 4	AUX 3	TRB
Tx	Low	High (@3.2V)	High (@4.8V)
Rx	High	Low	Low
Battery Saver	Low	Low	Hi-Z/Float (@2.5V)

In the receive mode, U241 pin 19 is low or grounded. This activates the receive VCO by enabling the receive oscillator and the receive buffer of U241. The RF signal at U241 pin 8 is run through a matching network. The resulting RF signal is the LO RF INJECTION and it is applied to the mixer at T302 (refer to *UHF Receiver Front End Schematic Diagram* on page 5B-21).

During the transmit condition, when PTT is depressed, five volts is applied to U241 pin 19. This activates the transmit VCO by enabling the transmit oscillator and the transmit buffer of U241. The RF signal at U241 pin 10 is injected into the input of the PA module (U101 pin16). This RF signal is the TX RF INJECTION. Also in transmit mode, the audio signal to be frequency modulated onto the carrier is received through the U201 pin 41.

When a high impedance is applied to U241 pin19, the VCO is operating in BATTERY SAVER mode. In this case, both the receive and transmit oscillators as well as the receive transmit and prescaler buffer are turned off.

7.0 Notes For All Schematics and Circuit Boards

* Component is frequency sensitive. Refer to the Electrical Parts List for value and usage.

1. Unless otherwise stated, resistances are in Ohms ($k = 1000$), and capacitances are in picofarads (pF) or microfarads (μF).
2. DC voltages are measured from point indicated to chassis ground using a Motorola DC multimeter or equivalent. Transmitter measurements should be made with a $1.2 \mu H$ choke in series with the voltage probe to prevent circuit loading.
3. Reference Designators are assigned in the following manner:

100 Series	=	Transmitter
200 Series	=	Frequency Generation
300 Series	=	Receiver
400/500 Series	=	Controller
600 Series	=	Keypad Board
4. Interconnect Tie Point Legend:

UNSWB+	=	Unswitch Battery Voltage (7.5V)
SWB+	=	Switch Battery Voltage (7.5V)
R5	=	Receiver Five Volts
CLK	=	Clock
Vdda	=	Regulated 3.3 Volts (for analog)
Vddd	=	Regulated 3.3 Volts (for digital)
CSX	=	Chip Select Line (not for LVZIF)
SYN	=	Synthesizer
DACRX	=	Digital to Analog Voltage (For Receiver Front End Filter)
VSF	=	Voltage Super Filtered (5 volts)
VR	=	Voltage Regulator

6-LAYER CIRCUIT BOARD DETAIL VIEWING COPPER STEPS IN PROPER LAYER SEQUENCE

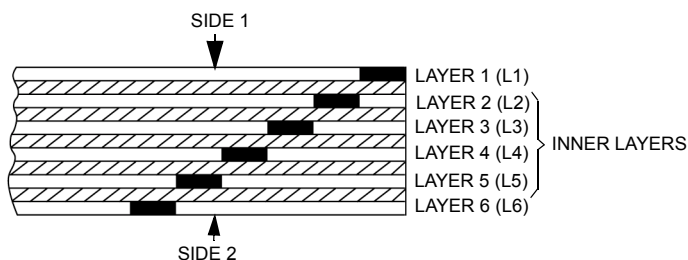

THIS PAGE INTENTIONALLY LEFT BLANK

8.0 Circuit Board/Schematic Diagrams and Parts List

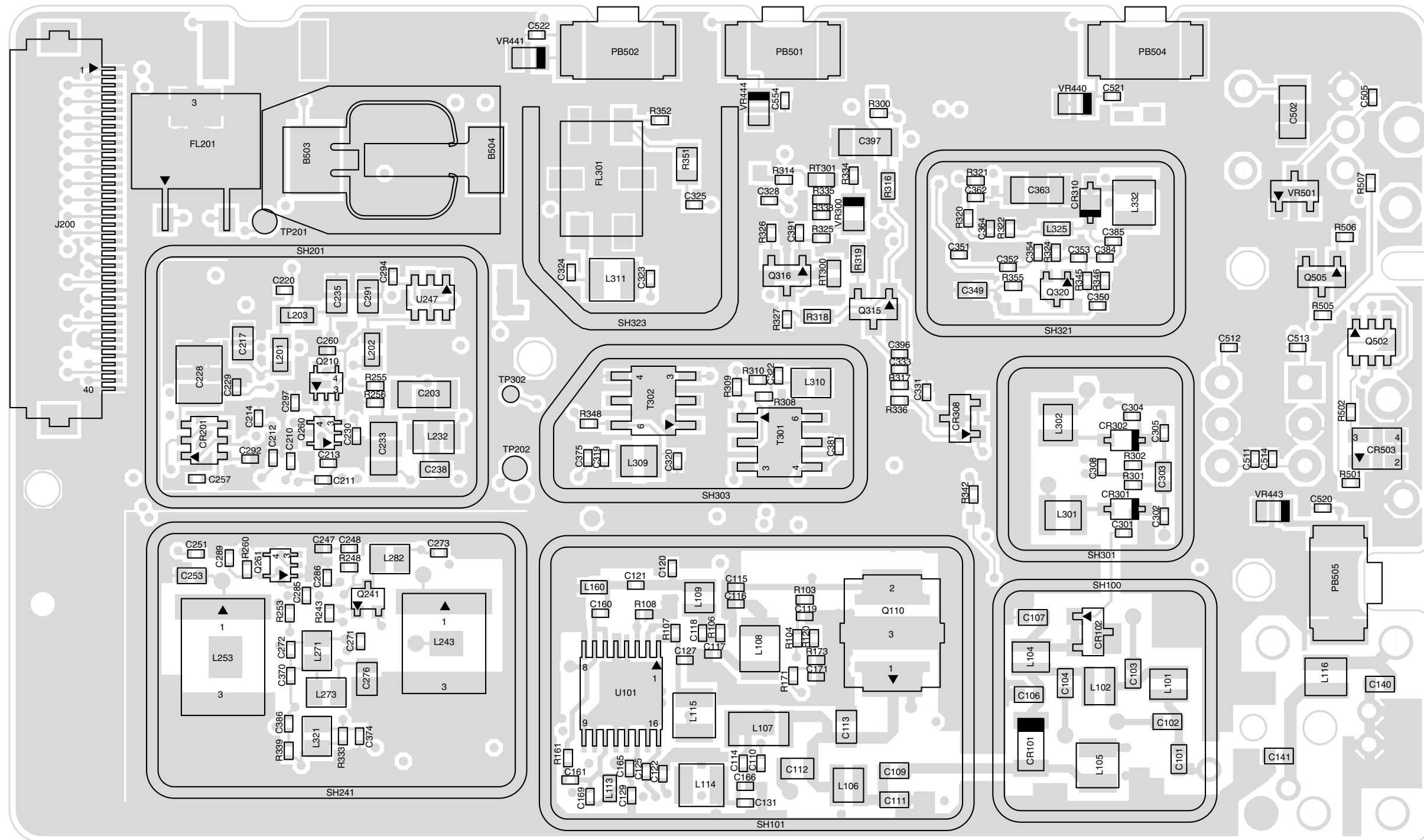

UHF (403-470MHz) Main Board Top Side PCB No. 8404077G05/G06/G07

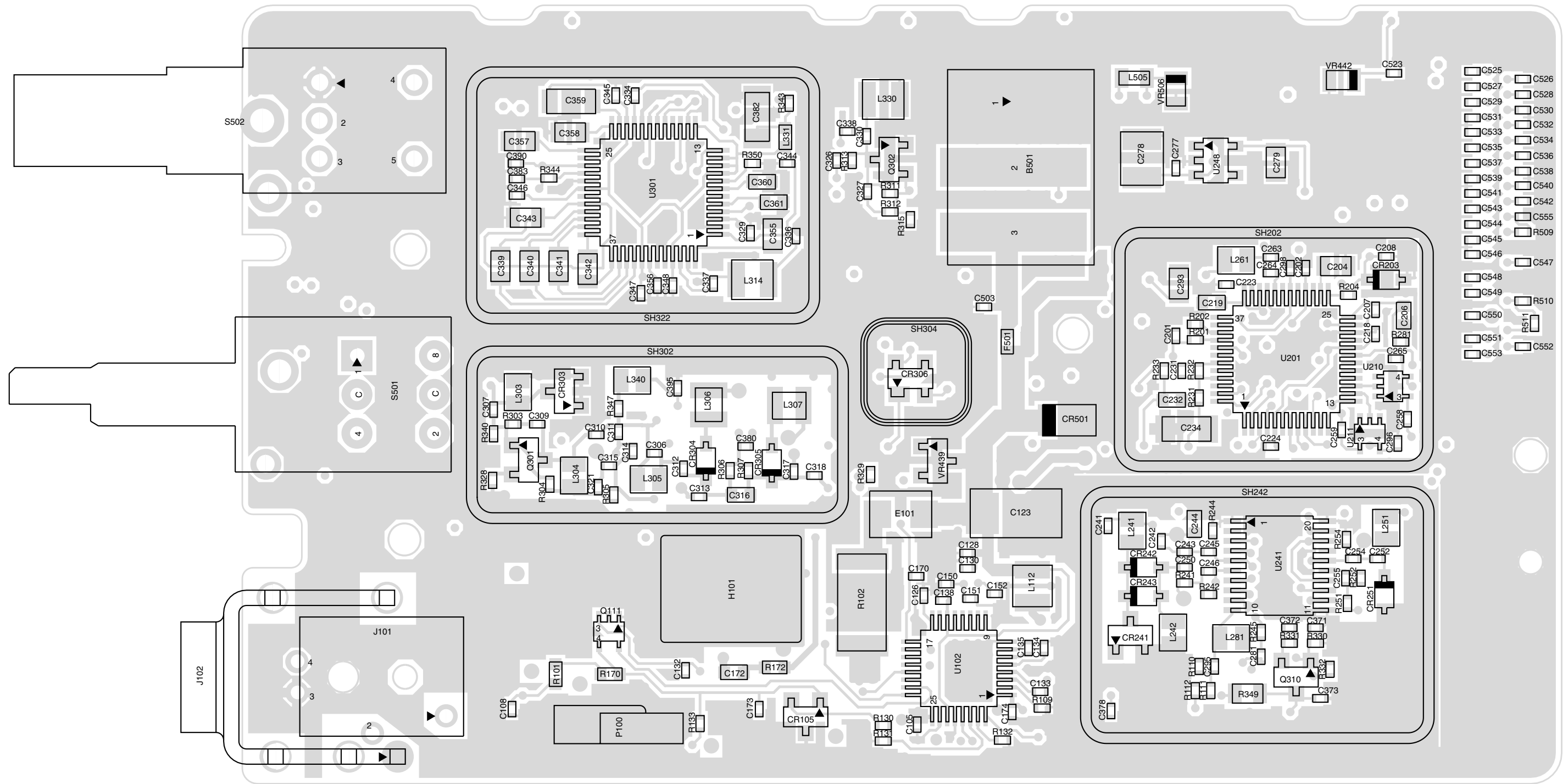

**UHF (403-470MHz) Main Board Bottom Side
PCB No. 8404077G05/G06/G07**

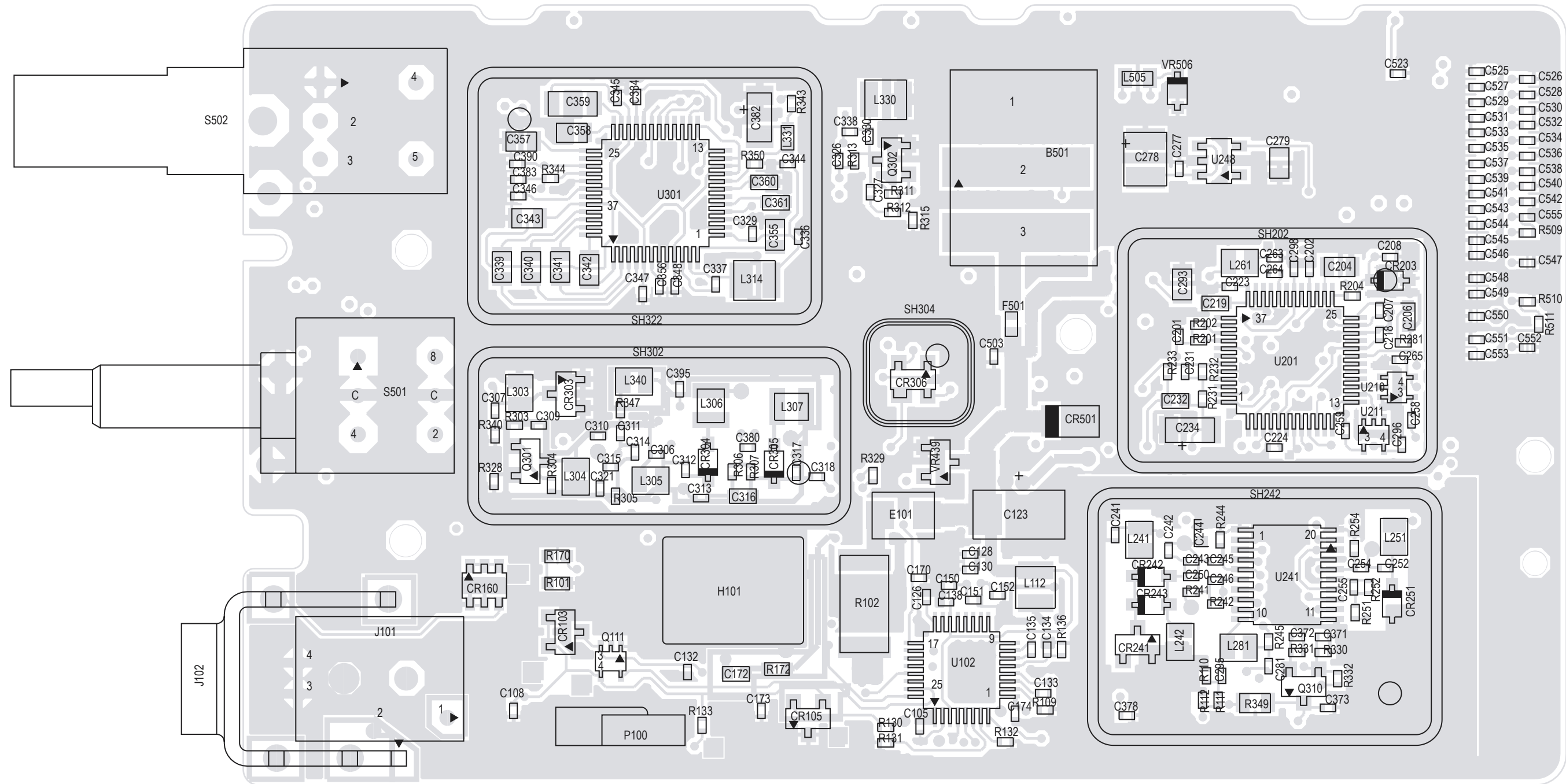

ZMY0131017-O

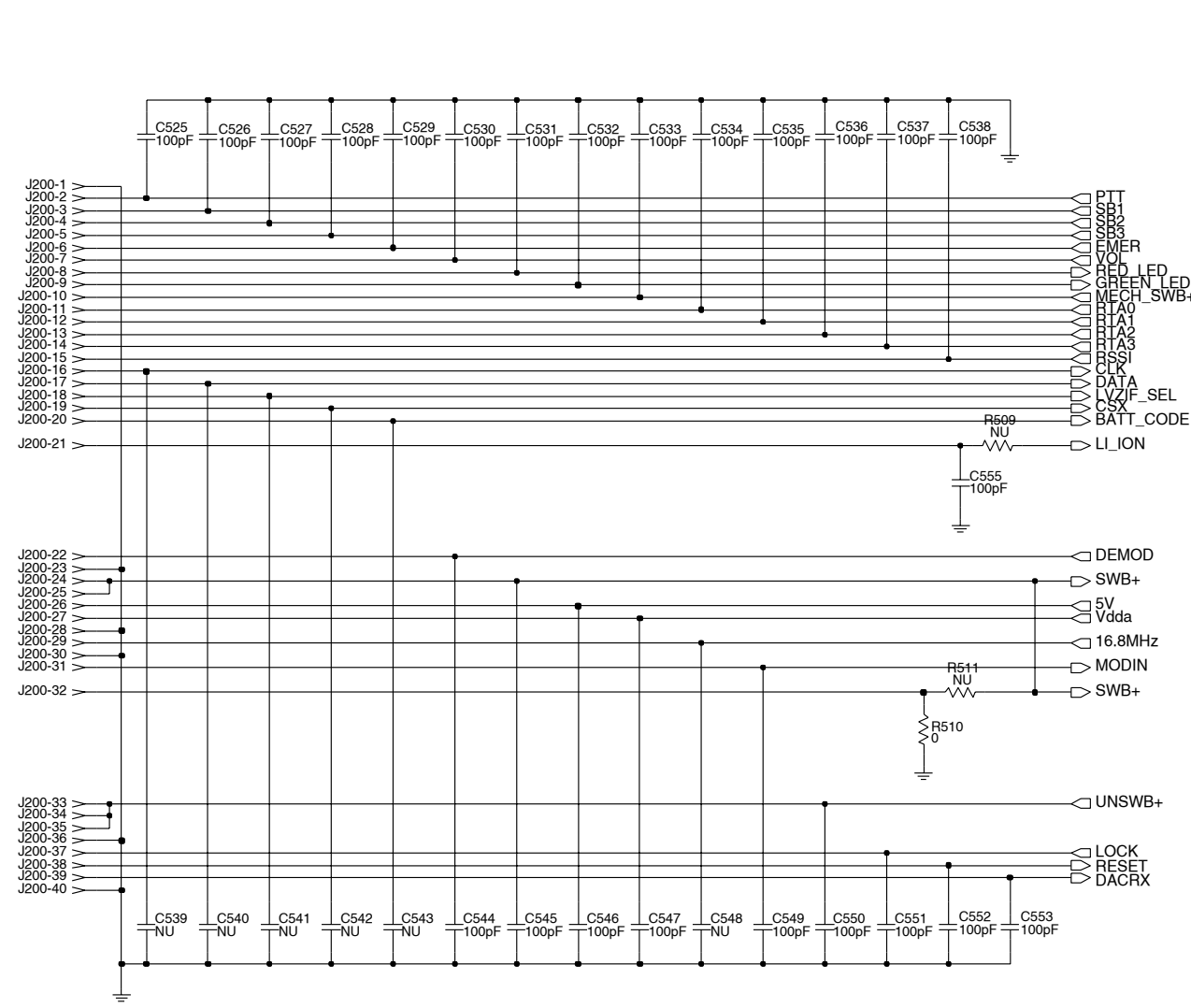

ZMY0130796-A

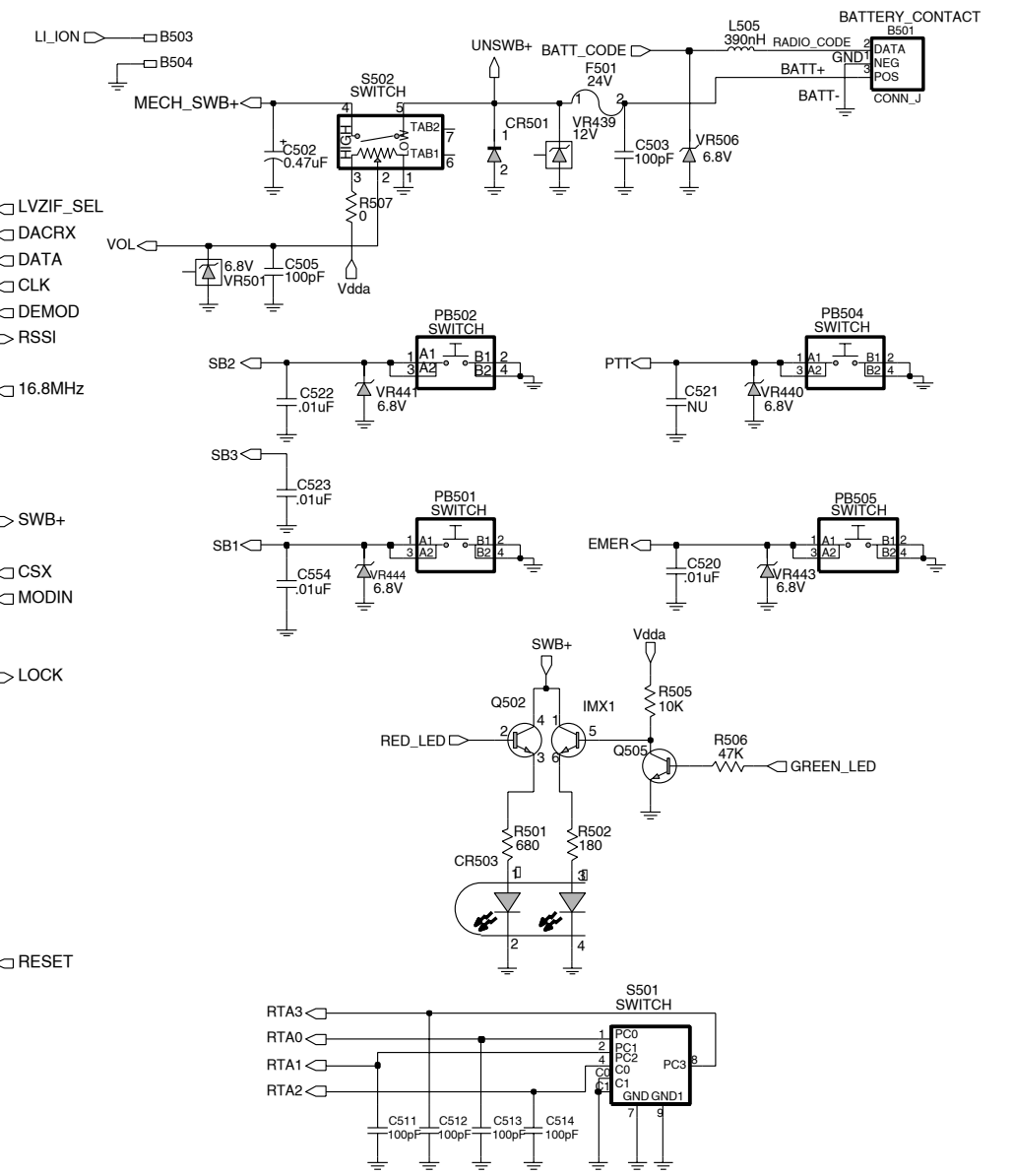
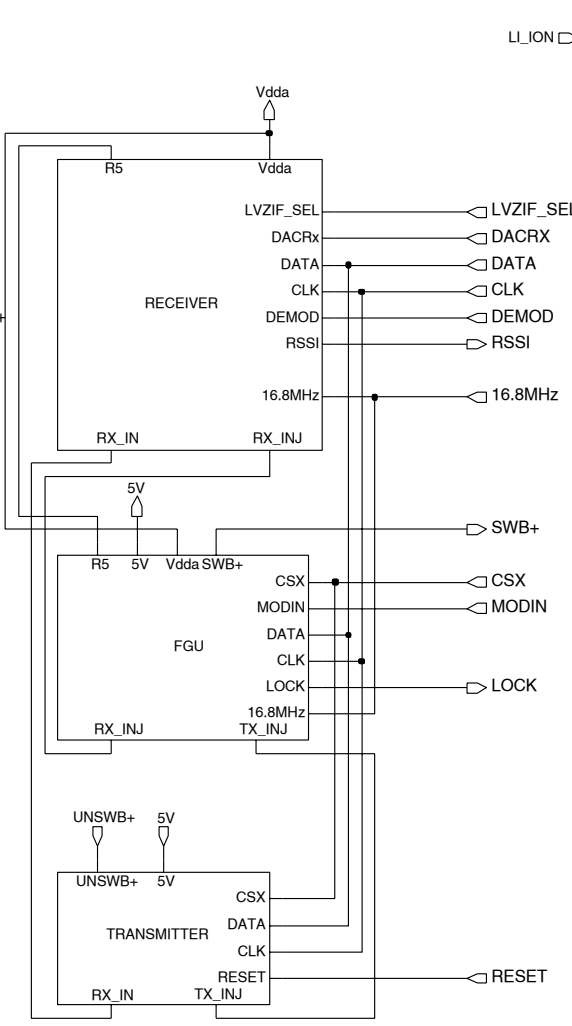

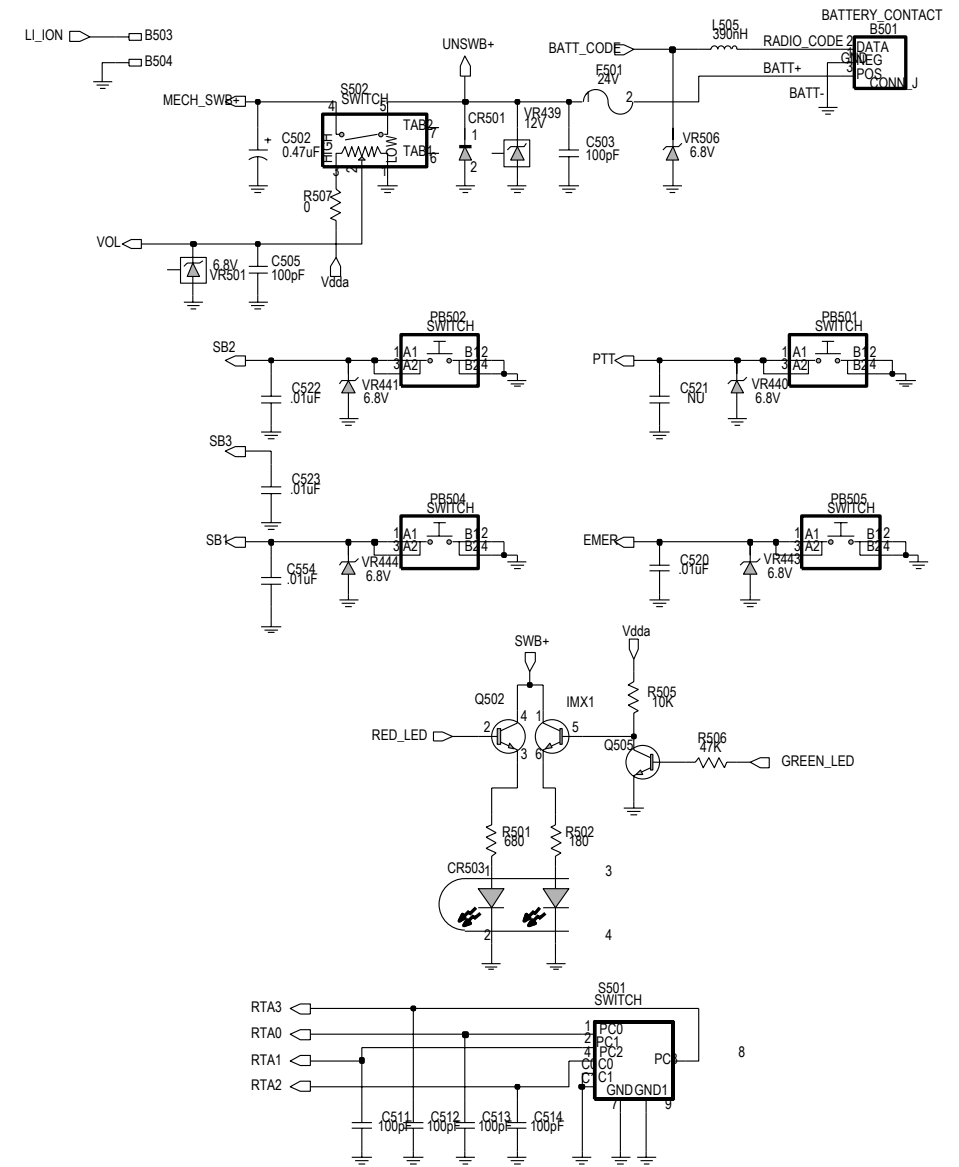
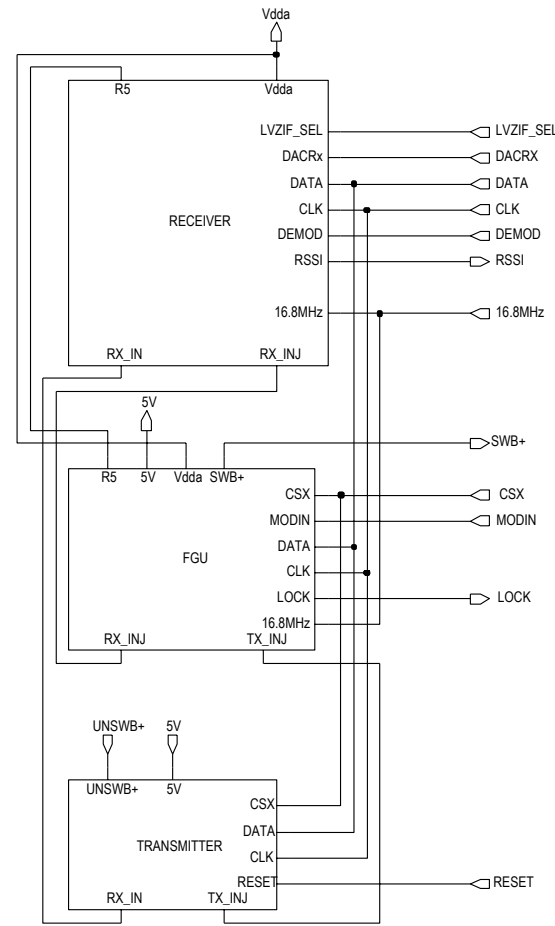
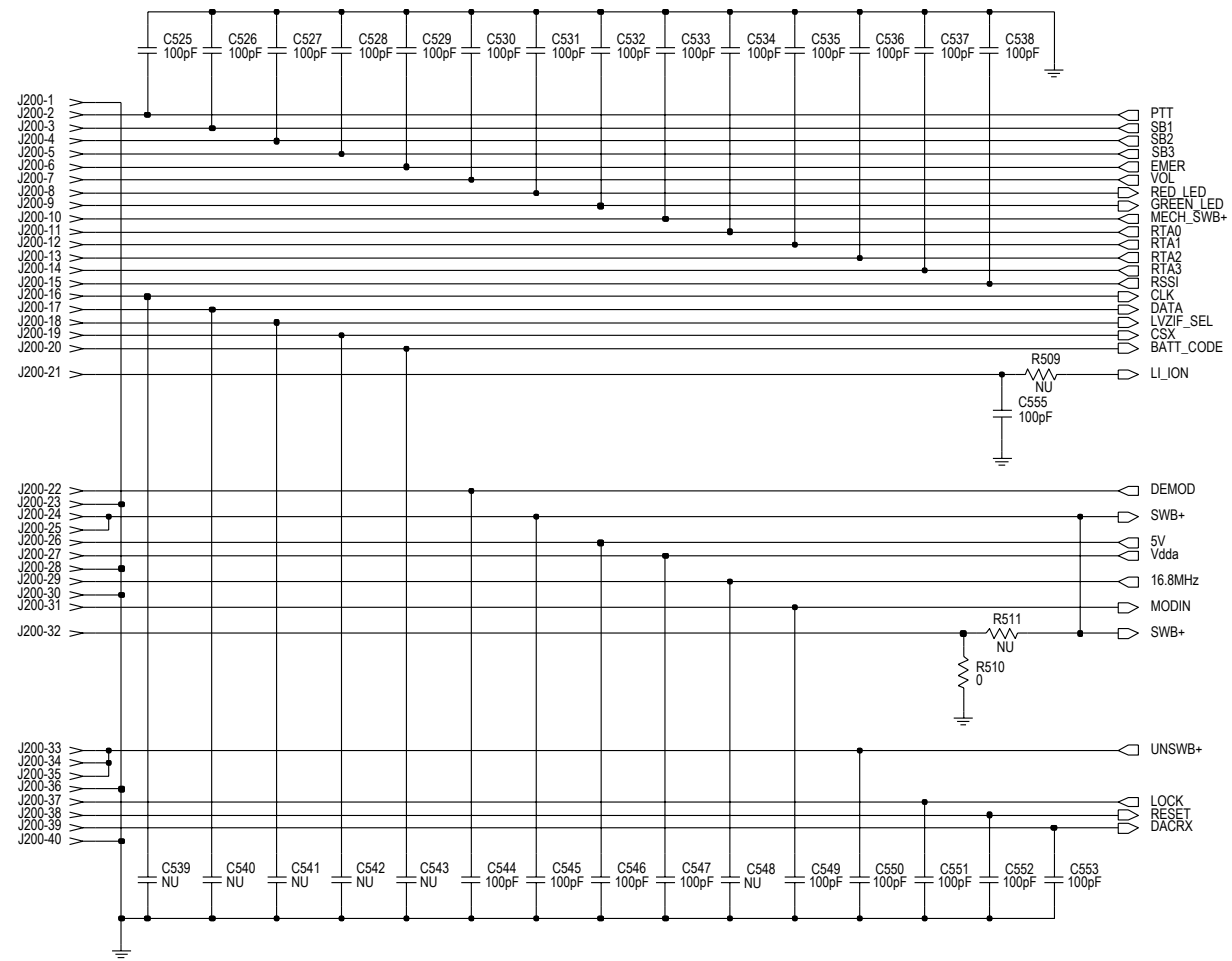

ZMY0130796-B

UHF Controls And Switches Schematic Diagram
(sheet 2 of 2 for 8404077G09 PCB)

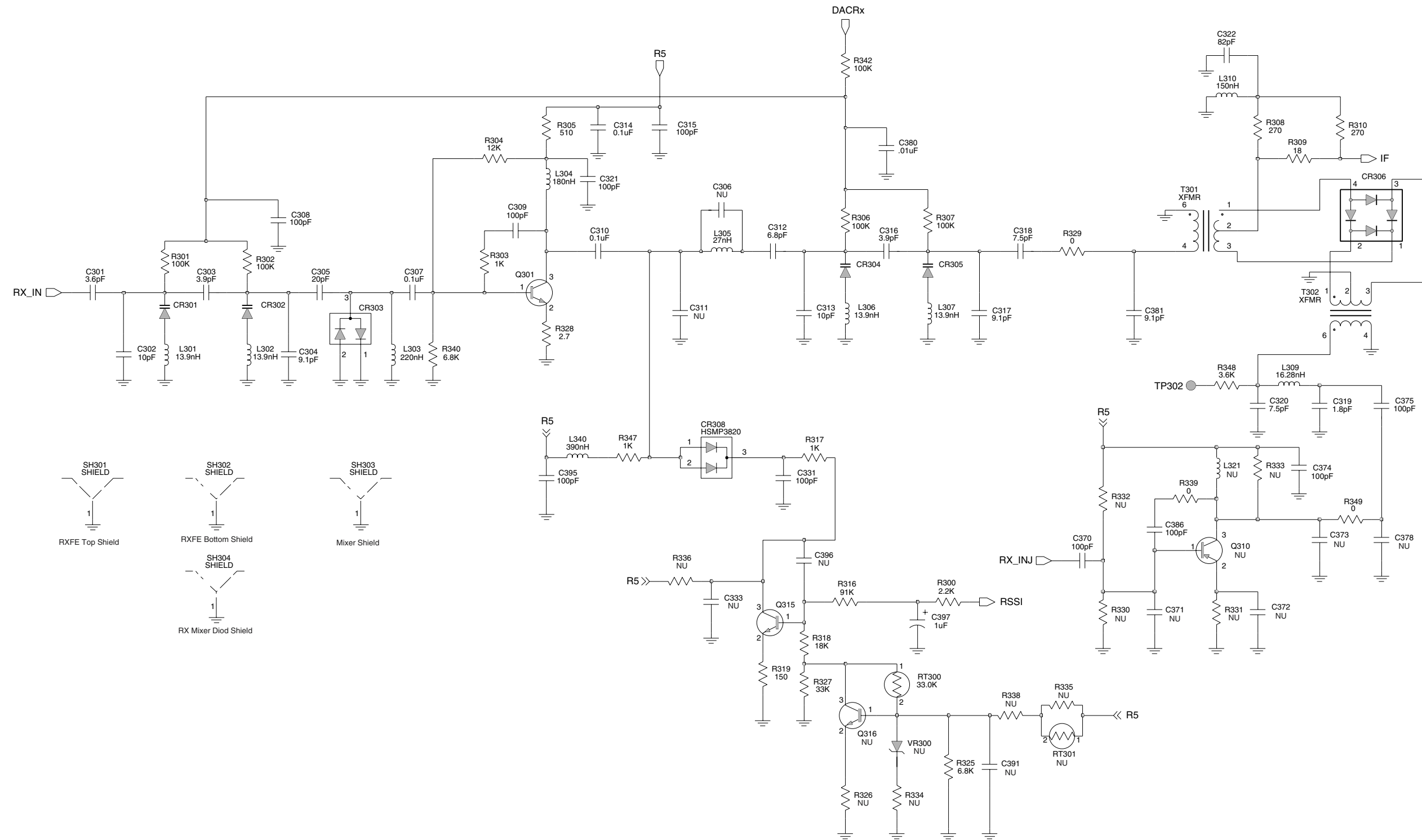

UHF Receiver Front End Schematic Diagram



UHF Receiver Back End Schematic Diagram

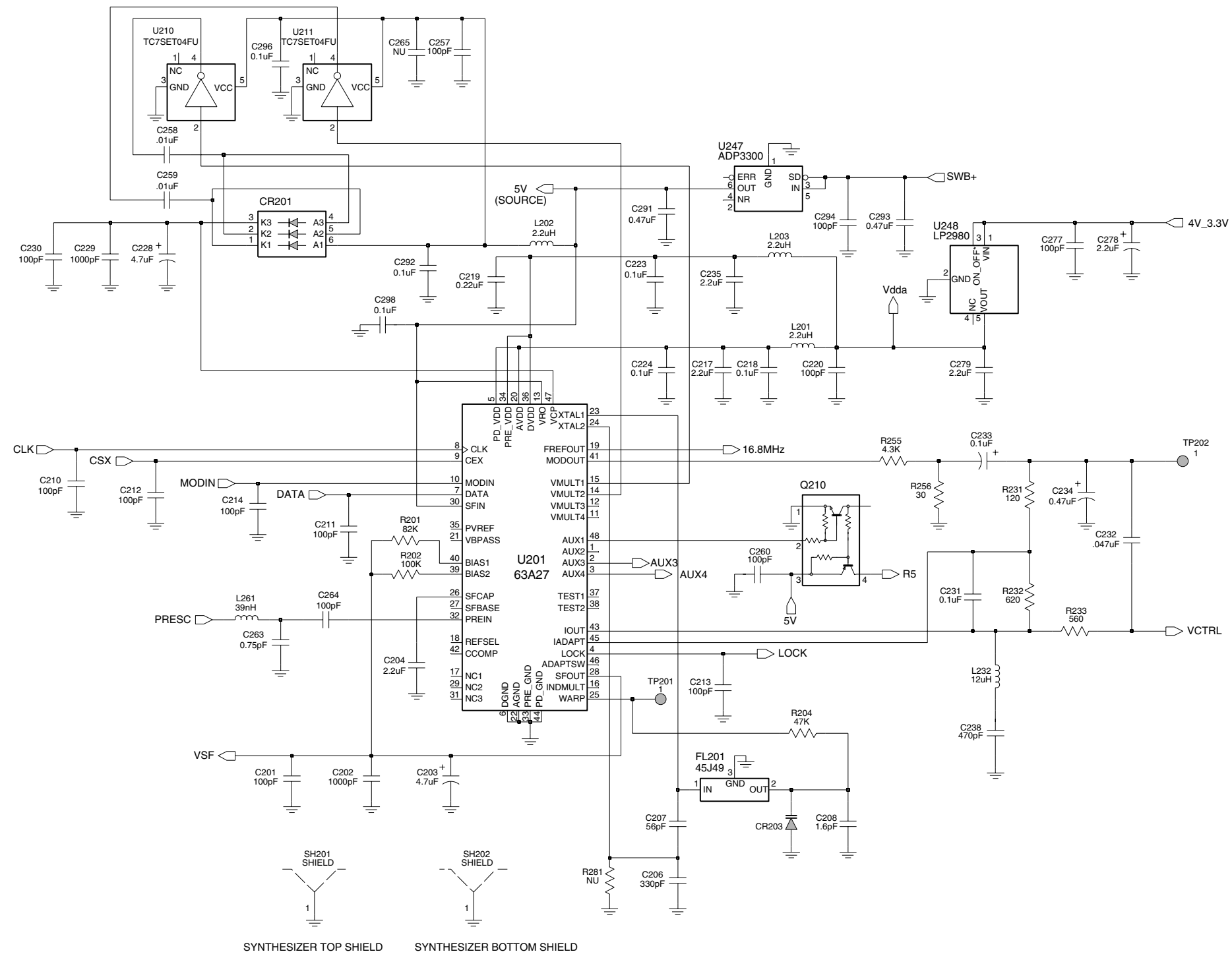

UHF Synthesizer Schematic Diagram

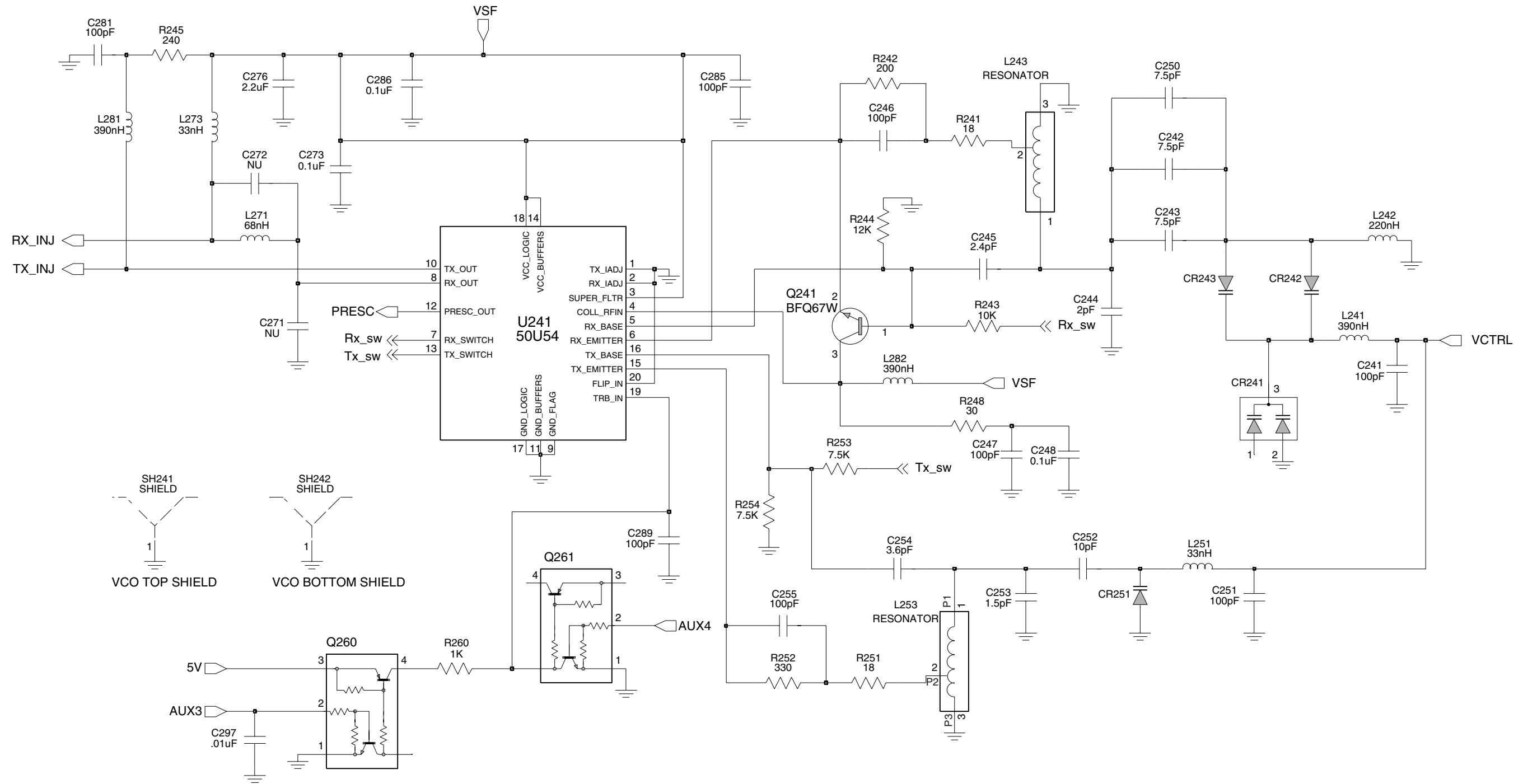

UHF Voltage Controlled Oscillator Schematic Diagram

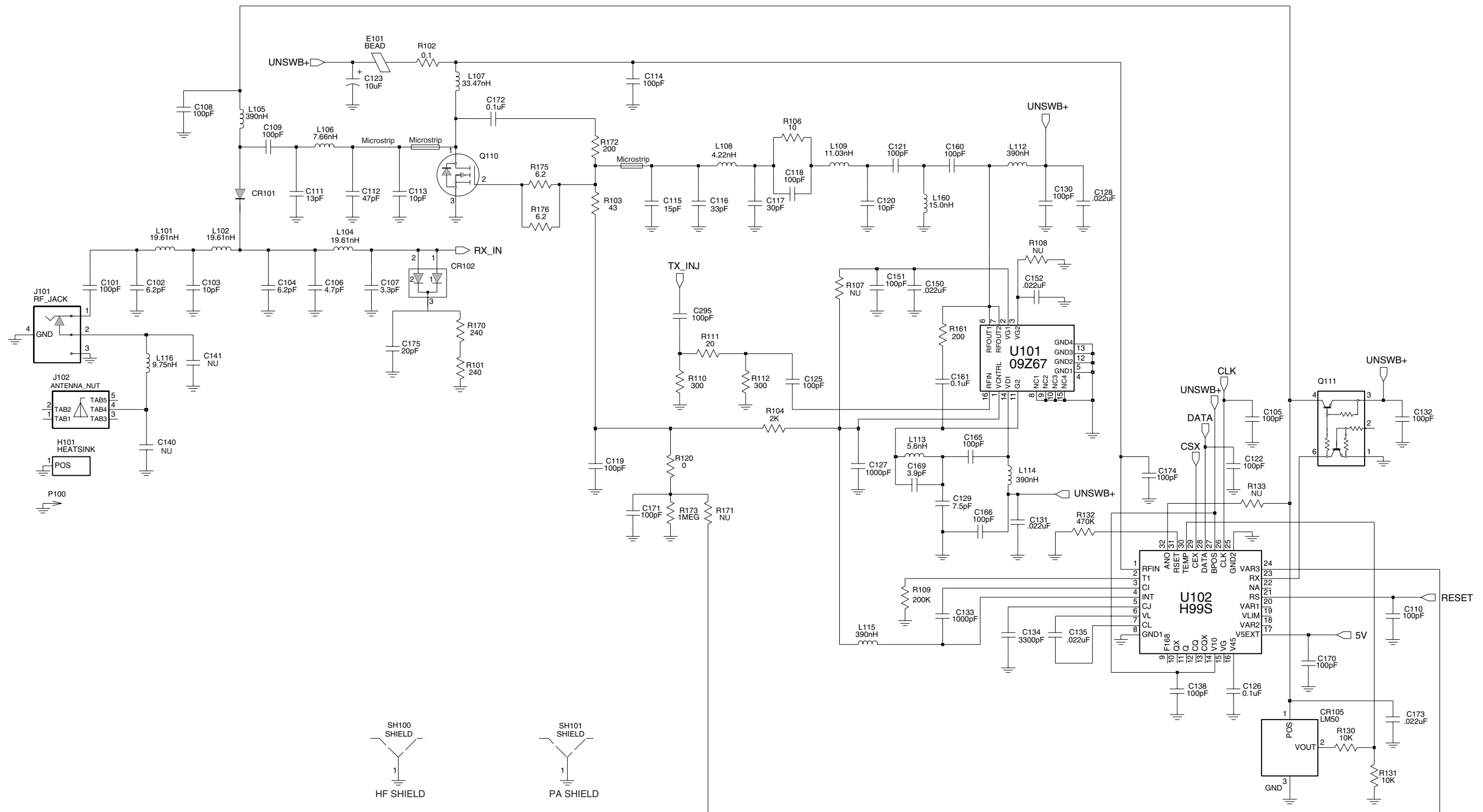

UHF Transmitter Schematic Diagram

UHF Band 1 Radio Parts List (RF Board)

Circuit Ref	Motorola Part No.	Description
B501	0986237A02	Battery Contact Connector
B503	3980502Z01	Contact, Backup B+ (not used in GP328 Plus)
B504	3980501Z01	Contact, Backup B- (not used in GP338 Plus)
C101	2113740F51	100
C102	2113740F22	6.2
C103	2113740F27	10.0
C104	2113740F22	6.2
C105	2113743N50	100.0 pF, 5%
C106	2113740F19	4.7 pF
C107	2113740F15	3.3
C108	2113743N50	100.0 pF, 5%
C109	2113740F51	100
C110	2113743N50	100.0 pF, 5%
C111	2113740F31	15 pF
C112	2180605Z32	47 pF
C113	2180605Z16	10 pF
C114	2113743N50	100.0 pF, 5%
C115	2113743N35	24 pF, 5%
C116	2113743N35	24 pF, 5%
C117	2113743N34	22.0 pF, 5%
C118	2113743N50	100.0 pF, 5%
C119	2113743N50	100.0 pF, 5%
C120	2113743N27	11.0 pF, 5%
C121	2113743N50	100.0 pF, 5%
C122	2113743N50	100.0 pF, 5%
C123	2311049A18	10 uF, 10%
C125	2113743N50	100.0 pF, 5%
C126	2113743M24	100000 pF, +80% / -20%
C127	2113743L17	1000 pF, 10%
C128	2113743M08	22000 pF, +80% / -20%
C129	2113743N23	7.5 pF, 0.5 pF
C130	2113743N50	100.0 pF, 5%
C131	2113743M08	22000 pF, +80% / -20%
C132	2113743N50	100.0 pF, 5%
C133	2113743L17	1000 pF, 10%
C134	2113743L29	3300 pF, 10%
C135	2113743M08	22000 pF, +80% / -20%
C138	2113743N50	100.0 pF, 5%
C140	0662057A67	5600, 5%
C141	NOT PLACED	
C150	2113743M08	22000 pF, +80% / -20%
C151	2113743N50	100.0 pF, 5%
C152	2113743M08	22000 pF, +80% / -20%
C160	2113743N50	100.0 pF, 5%
C161	2113743M24	100000 pF, +80% / -20%

Circuit Ref	Motorola Part No.	Description
C165	2113743N50	100.0 pF, 5%
C166	2113743N50	100.0 pF, 5%
C169	2113743N20	5.6 pF, 0.5 pF
C170	2113743N50	100.0 pF, 5%
C171	2113743N50	100.0 pF, 5%
C172	2113740F51	100
C173	2113743M08	22000 pF, +80% / -20%
C174	2113743N50	100.0 pF, 5%
C175	2113740F51	100
C201	2113743N50	100.0 pF, 5%
C202	2113743L17	1000 pF, 10%
C203	2311049A56	4.7 uF
C204	2104993J02	2.2 uF
C206	2113740F63	330, 5%
C207	2113743N40	39.0 pF, 5%
C208	NOT PLACED	
C210	2113743N50	100.0 pF, 5%
C211	2113743N50	100.0 pF, 5%
C212	2113743N50	100.0 pF, 5%
C213	2113743N50	100.0 pF, 5%
C214	2113743N50	100.0 pF, 5%
C217	2104993J02	2.2 uF
C218	2113743M24	100000 pF, +80% / -20%
C219	2113743K16	0.220 uF, +80% / -20%
C220	2113743N50	100.0 pF, 5%
C223	2113743M24	100000 pF, +80% / -20%
C224	2113743M24	100000 pF, +80% / -20%
C228	2311049J11	4.7 uF, 10%
C229	2113743L17	1000 pF, 10%
C230	2113743N50	100.0 pF, 5%
C231	2113743M24	100000 pF, +80% / -20%
C232	2113743E12	0.047 uF, 10%
C233	2311049A01	0.1
C234	2311049A05	0.47 uF, 10%
C235	2104993J02	2.2 uF
C238	2113741F17	470
C241	2113743N50	100.0 pF, 5%
C242	2113743N23	7.5 pF, 0.5 pF
C243	2113743N23	7.5 pF, 0.5 pF
C244	2113740F10	2.0
C245	2113743N11	2.4 pF, 0.25 pF
C246	2113743N50	100.0 pF, 5%
C247	2113743N50	100.0 pF, 5%
C248	2113743M24	100000 pF, +80% / -20%
C250	2113743N23	7.5 pF, 0.5 pF
C251	2113743N50	100.0 pF, 5%
C252	2113743N26	10.0 pF, 5%
C253	2113740F09	1.8
C254	2113743N15	3.6 pF, 0.25 pF
C255	2113743N50	100.0 pF, 5%
C257	2113743N50	100.0 pF, 5%

Circuit Ref	Motorola Part No.	Description
C258	2113743L41	10000 pF, 10%
C259	2113743L41	10000 pF, 10%
C260	2113743N50	100.0 pF, 5%
C263	2113743N02	0.75 pF, 0.25 pF
C264	2113743N50	100.0 pF, 5%
C265	NOT PLACED	
C271	NOT PLACED	
C272	NOT PLACED	
C273	2113743M24	100000 pF, +80% / -20%
C276	2104993J02	2.2 uF
C277	2113743N50	100.0 pF, 5%
C278	2311049A09	2.2 uF, 10%
C279	2104993J02	2.2 uF
C281	2113743N50	100.0 pF, 5%
C285	2113743N50	100.0 pF, 5%
C286	2113743M24	100000 pF, +80% / -20%
C289	2113743N50	100.0 pF, 5%
C291	2311049A69	10.0 uF, 20%
C292	2113743M24	100000 pF, +80% / -20%
C293	2113743A27	0.470 uF, 10%
C294	2113743N50	100.0 pF, 5%
C295	2113743N50	100.0 pF, 5%
C296	2113743M24	100000 pF, +80% / -20%
C297	2113743L41	10000 pF, 10%
C298	2113743M24	100000 pF, +80% / -20%
C301	2113743N15	3.6 pF, 0.25 pF
C302	2113743N26	10.0 pF, 5%
C303	2113740L08	3.9 pF, 0.1 pF
C304	2113743N26	10.0 pF, 5%
C305	2113743N33	20.0 pF, 5%
C306	NOT PLACED	
C307	2113743M24	100000 pF, +80% / -20%
C308	2113743N50	100.0 pF, 5%
C309	2113743N50	100.0 pF, 5%
C310	2113743M24	100000 pF, +80% / -20%
C311	NOT PLACED	
C312	2113743N25	9.1 pF, 0.5 pF
C313	2113743N26	10.0 pF, 5%
C314	2113743M24	100000 pF, +80% / -20%
C315	2113743N50	100.0 pF, 5%
C316	2113740L08	3.9 pF, 0.1 pF
C317	2113743N25	9.1 pF, 0.5 pF
C318	2113743N23	7.5 pF, 0.5 pF
C319	2113743N69	1.8 pF, 0.25 pF
C320	2113743N23	7.5 pF, 0.5 pF
C321	2113743N50	100.0 pF, 5%
C322	2113743N48	82.0 pF, 5%
C323	2113743N54	150.0 pF, 5%
C324	2113743N33	20.0 pF, 5%
C325	2113743L41	10000 pF, 10%
C326	2113743L41	10000 pF, 10%

Circuit Ref	Motorola Part No.	Description
C327	2113743N50	100.0 pF, 5%
C328	2113743M24	100000 pF, +80% / -20%
C329	2113743M24	100000 pF, +80% / -20%
C330	2113743N26	10.0 pF, 5%
C331	2113743N50	100.0 pF, 5%
C333	NOT PLACED	
C334	2113743M08	22000 pF, +80% / -20%
C336	2113743M24	100000 pF, +80% / -20%
C337	2113743N50	100.0 pF, 5%
C338	2113743N30	15.0 pF, 5%
C339	2180478Z20	1.0 uF
C340	2180478Z20	1.0 uF
C341	2180478Z20	1.0 uF
C342	2180478Z20	1.0 uF
C343	2113743A23	0.220 uF, 10%
C344	2113743M24	100000 pF, +80% / -20%
C345	2113743M24	100000 pF, +80% / -20%
C346	2113743M24	100000 pF, +80% / -20%
C347	2113743M24	100000 pF, +80% / -20%
C348	2113743M24	100000 pF, +80% / -20%
C349	2113743E07	0.022 uF
C350	2113743L05	330 pF, 10%
C351	2113743N33	20.0 pF, 5%
C352	2113743N28	12.0 pF, 5%
C353	2113743N41	43.0 pF, 5%
C354	2113743N42	47.0 pF, 5%
C355	2113743A24	0.330 uF, 10%
C356	2113743M08	22000 pF, +80% / -20%
C357	2113743A23	0.220 uF, 10%
C358	2113741A23	1200 pF, 5%
C359	2109720D14	0.1 uF
C360	2113743E07	0.022 uF
C361	2113741F49	10000
C362	2113743M08	22000 pF, +80% / -20%
C363	2311049A40	2.2 uF, 10%
C364	2113743L41	10000 pF, 10%
C370	2113743N50	100.0 pF, 5%
C371	NOT PLACED	
C372	NOT PLACED	
C373	NOT PLACED	
C374	2113743N50	100.0 pF, 5%
C375	2113743N50	100.0 pF, 5%
C378	NOT PLACED	
C380	2113743L41	10000 pF, 10%
C381	2113743N21	6.2 pF, 0.5 pF
C382	2311049A59	10 uF, 10%
C383	2113743N50	100.0 pF, 5%
C384	2113743N44	56.0 pF, 5%
C385	2113743N44	56.0 pF, 5%
C386	2113743N50	100.0 pF, 5%
C390	2113743N50	100.0 pF, 5%

Circuit Ref	Motorola Part No.	Description	Circuit Ref	Motorola Part No.	Description	Circuit Ref	Motorola Part No.	Description	Circuit Ref	Motorola Part No.	Description
C391	NOT PLACED		CR201	4802233J09	Triple Diode	L281	2462587V41	390 nH, 10%	R130	0662057M98	10 k, 5%
C395	2113743N50	100.0 pF, 5%	CR203	4862824C03	Varactor Diode	L282	2462587V41	390 nH, 10%	R131	0662057N05	18 k, 5%
C396	NOT PLACED		CR241	4805649Q13	Varactor Diode	L301	2479990C01	13.9 nH	R132	0662057N33	270 k, 5%
C397	2311049A05	0.47 uF, 10%	CR242	4862824C01	Varactor Diode	L302	2479990C01	13.9 nH	R133	NOT PLACED	
C502	2311049A05	0.47 uF, 10%	CR243	4862824C01	Varactor Diode	L303	2462587V26	22 nH, 5%	R136	NOT PLACED	
C503	2113743N50	100.0 pF, 5%	CR251	4802245J22	Varactor Diode	L304	2462587V37	180 nH, 5%	R161	0662057M57	200, 5%
C505	2113743N50	100.0 pF, 5%	CR301	4862824C01	Varactor Diode	L305	2462587V26	22 nH, 5%	R170	0662057A34	240, 5%
C511	2113743N50	100.0 pF, 5%	CR302	4862824C01	Varactor Diode	L306	2479990C01	13.9 nH	R171	0662057N14	43 k, 5%
C512	2113743N50	100.0 pF, 5%	CR303	4880154K03	Dual Diode	L307	2479990C01	13.9 nH	R172	0662057A32	200, 5%
C513	2113743N50	100.0 pF, 5%	CR304	4862824C01	Varactor Diode	L309	2479990C02	16.28 nH	R173	0662057N29	180 k, 5%
C514	2113743N50	100.0 pF, 5%	CR305	4862824C01	Varactor Diode	L310	2462587V36	150 nH, 5%	R174	0662057N15	47 k, 5%
C520	2113743L41	10000 pF, 10%	CR306	4802245J42	Ring Quad Diode	L311	2462587N65	750 nH, 5%	R175	0662057B59	3.0, 5%
C521	NOT PLACED		CR308	4802245J41	PIN Diode	L314	2462587N72	2200 nH, 5%	R176	0662057B59	3.0, 5%
C522	2113743L41	10000 pF, 10%	CR310	4862824C01	Varactor Diode	L321	NOT PLACED		R201	0662057N21	82 k, 5%
C523	2113743L41	10000 pF, 10%	CR501	4880107R01	Rectifier	L325	2480646Z20	2.20 uH	R202	0662057N23	100 k, 5%
C525	2113743N50	100.0 pF, 5%	CR503	4805729G49	Red / Yellow Diode	L330	2462587N64	680 nH, 5%	R204	0662057N15	47 k, 5%
C526	2113743N50	100.0 pF, 5%	E101	2484657R01	Inductor Bead Chip	L331	2480646Z20	2.20 uH	R231	0662057M52	120, 5%
C527	2113743N50	100.0 pF, 5%	F501	6580542Z01	Fuse 3A	L332	2462587N53	100 nH, 5%	R232	0662057M69	620, 5%
C528	2113743N50	100.0 pF, 5%	FL201	**4805875Z04	Crystal 16.8 MHz	L340	2462587V41	390 nH, 10%	R233	0662057M68	560, 5%
C529	2113743N50	100.0 pF, 5%	FL301	9186153B01	X'tal Filter	L505	2462587Q42	390 nH, 10%	R241	0662057M32	18, 5%
C530	2113743N50	100.0 pF, 5%	H101	2680499Z01	Heat Spreader	P100	3905643V01	Ground Contact	R242	0662057M57	200, 5%
C531	2113743N50	100.0 pF, 5%	J101	0985613Z01	RF Jack	PB501	4070354A01	Light Touch Switch	R243	0662057M98	10 k, 5%
C532	2113743N50	100.0 pF, 5%	J102	0280519Z02	Antenna Nut (Ref: 0280519Z04)	PB502	4070354A01	Light Touch Switch	R244	0662057N01	12 k, 5%
C533	2113743N50	100.0 pF, 5%	J200	0905505Y04	Conn ZIF Horizontal	PB504	4070354A01	Light Touch Switch	R245	0662057M59	240, 5%
C534	2113743N50	100.0 pF, 5%	L101	2479990B02	19.61 nH	PB505	4070354A01	Light Touch Switch	R248	0662057M37	30, 5%
C535	2113743N50	100.0 pF, 5%	L102	2479990B02	19.61 nH	Q110	4813828A09	Transistor 8W 450MHz	R251	0662057M32	18, 5%
C536	2113743N50	100.0 pF, 5%	L104	2479990B02	19.61 nH	Q111	4809939C05	Transistor Dual NPN / PNP	R252	0662057M62	330, 5%
C537	2113743N50	100.0 pF, 5%	L105	2462587N22	390 nH, 10%	Q210	4809939C05	Transistor Dual NPN / PNP	R253	0662057M95	7500, 5%
C538	2113743N50	100.0 pF, 5%	L106	2479990A02	7.66 nH	Q241	4805218N63	RF Transistor BFQ67W	R254	0662057M95	7500, 5%
C539	NOT PLACED		L107	2479990G01	33.47 nH	Q260	4809939C05	Transistor Dual NPN / PNP	R255	0662057M89	4300, 5%
C540	NOT PLACED		L108	2479990A01	4.22 nH	Q261	4809939C05	Transistor Dual NPN / PNP	R256	0662057M37	30, 5%
C541	NOT PLACED		L109	2479990B01	11.03 nH	Q301	4802245J44	NPN Silicon Bipolar Transistor	R260	0662057M74	1000, 5%
C542	NOT PLACED		L112	2462587N45	22 nH, 5%	Q302	4802245J44	NPN Silicon Bipolar Transistor	R281	NOT PLACED	
C543	NOT PLACED		L113	2413926H09	5.6 nH, 0.3 nH	Q310	NOT PLACED		R300	0662057M82	2200, 5%
C544	2113743N50	100.0 pF, 5%	L114	2462587N45	22 nH, 5%	Q315	4880214G02	Transistor MMBT3904	R301	0662057N23	100 k, 5%
C545	2113743N50	100.0 pF, 5%	L115	2462587N22	390 nH, 10%	Q316	NOT PLACED		R302	0662057N23	100 k, 5%
C546	2113743N50	100.0 pF, 5%	L116	2479990A03	9.75 nH	Q320	4805218N63	RF Transistor BFQ67W	R303	0662057M74	1000, 5%
C547	2113743N50	100.0 pF, 5%	L160	2413926H14	15.0 nH, 5%	Q502	5180159R01	Dual Transistor NPN	R304	0662057N01	12 k, 5%
C548	NOT PLACED		L201	2462587Q20	2200 nH, 20%	Q505	4880214G02	Transistor MMBT3904	R305	0662057M67	510, 5%
C549	2113743N50	100.0 pF, 5%	L202	2462587Q20	2200 nH, 20%	R101	0662057A34	240, 5%	R306	0662057N23	100 k, 5%
C550	2113743N50	100.0 pF, 5%	L203	2462587Q20	2200 nH, 20%	R102	0680539Z01	Power Metal Strip Resistor	R307	0662057N23	100 k, 5%
C551	2113743N50	100.0 pF, 5%	L232	2462587P25	12000 nH, 5%	R103	0662057M41	43, 5%	R308	0662057M60	270, 5%
C552	2113743N50	100.0 pF, 5%	L241	2462587V41	390 nH, 10%	R104	0662057N15	47 k, 5%	R309	0662057M32	18, 5%
C553	2113743N50	100.0 pF, 5%	L242	2462587V38	220 nH, 5%	R106	0662057M26	10, 5%	R310	0662057M60	270, 5%
C554	2113743L41	10000 pF, 10%	L243	2460593C01	Teflon Resonator	R107	NOT PLACED		R311	0662057N10	30 k, 5%
C555	2113743N50	100.0 pF, 5%	L251	2462587V28	33 nH, 5%	R108	0662057M92	5600, 5%	R312	0662057M83	2400, 5%
CR101	4880973Z02	PIN Diode	L253	2460593C02	Teflon Resonator	R109	0662057N30	200 k, 5%	R313	0662057M62	330, 5%
CR102	4802245J41	PIN Diode	L261	2462587V29	39 nH, 5%	R110	0662057M61	300, 5%	R314	0662057M85	3000, 5%
CR103	4802245J41	PIN Diode	L271	2462587V32	68 nH, 5%	R111	0662057M33	20, 5%	R315	0662057N01	12 k, 5%
CR105	5185963A15	Temperature Sensor	L273	2462587V28	33 nH, 5%	R112	0662057M61	300, 5%	R316	0662057A96	91 k, 5%
CR160	NOT PLACED					R120	0662057N14	43 k, 5%	R317	0662057M74	1000, 5%

Circuit Ref	Motorola Part No.	Description
R318	0662057A79	18 k, 5%
R319	0662057A29	150, 5%
R320	0662057M74	1000, 5%
R321	0662057M83	2400, 5%
R322	0662057N30	200 k, 5%
R324	0662057M81	2000, 5%
R325	0662057M94	6800, 5%
R326	NOT PLACED	
R327	0662057N11	33 k, 5%
R328	0662057M12	2.7, 5%
R329	0662057M01	0, 5%
R330	NOT PLACED	
R331	NOT PLACED	
R332	NOT PLACED	
R333	NOT PLACED	
R334	NOT PLACED	
R335	NOT PLACED	
R336	NOT PLACED	
R338	NOT PLACED	
R339	0662057M01	0, 5%
R340	0662057M94	6800, 5%
R342	0662057N23	100 k, 5%
R343	0662057M26	10, 5%
R344	0662057N01	12 k, 5%
R345	0662057M98	10 k, 5%
R346	0662057N17	56 k, 5%
R347	0662057M74	1000, 5%
R348	0662057M87	3600, 5%
R349	0662057C01	0
R350	0662057N23	100 k, 5%
R351	0662057C01	0
R352	0662057M86	3300, 5%
R355	0662057M01	0, 5%
R501	0662057M70	680, 5%
R502	0662057M56	180, 5%
R505	0662057M98	10 k, 5%
R506	0662057N15	47 k, 5%
R507	0662057M01	0, 5%
R509	0662057M01	0, 5% (not used in GP328 Plus)
R510	0662057M01	0, 5%
R511	NOT PLACED	
RT300	0680590Z01	Thermistor 33k
RT301	NOT PLACED	
S501	4080710Z01	Channel Switch (Ref: 4080710Z09)
	4080710Z05	Channel Switch (used in PMUE2048_ only) (Ref: 4080710Z12)
S502	1880619Z02	Potentiometer (Volume)
SH100	2680507Z01	Shield, Harmonic Filter

Circuit Ref	Motorola Part No.	Description
SH101	2680510Z01	Shield, PA
SH201	2680511Z01	Shield, Synthesizer
SH202	2680511Z01	Shield, Synthesizer
SH241	2604120G01	Shield, VCO
SH242	2680514Z01	Shield, VCO Bottom / LVZIF
SH301	2680554Z01	Shield, Receiver Front End Top
SH302	2680555Z01	Shield, Receiver Front End Bottom
SH303	2680509Z01	Shield, Mixer
SH304	2680624Z01	Shield, Mixer Diode
SH321	2680508Z01	Shield, LVZIF 2nd LO
SH322	2680514Z01	Shield, VCO Bottom / LVZIF
SH323	2604082P01	Shield, X'tal Filter
T301	2580541Z02	Balun Transformer
T302	2580541Z02	Balun Transformer
TP201	NOT PLACED	
TP202	NOT PLACED	
TP302	NOT PLACED	
U101	5185130C65	LD MOS Driver
U102	5185765B26	PCIC
U201	5185963A27	LVFRACN
U210	5102463J61	Inverter
U211	5102463J61	Inverter
U241	5105750U54	VCO Buffer
U247	5105739X05	5V Regulator
U248	5102463J58	3.3V Regulator
U301	5109632D83	LVZIF
VR300	NOT PLACED	
VR439	4880140L17	12V Zener Diode
VR440	4802245J73	6.8V Zener Diode
VR441	4802245J73	6.8V Zener Diode
VR443	4802245J73	6.8V Zener Diode
VR444	4802245J73	6.8V Zener Diode
VR501	4813830A18	6.8V Diode
VR506	4802245J73	6.8V Zener Diode
	8404077G05	RF PCB
	8404077G06	RF PCB
	8404077G07	RF PCB
	8404077G09	RF PCB

* Motorola Depot Servicing only

** Not Serviceable

9.0 Troubleshooting charts

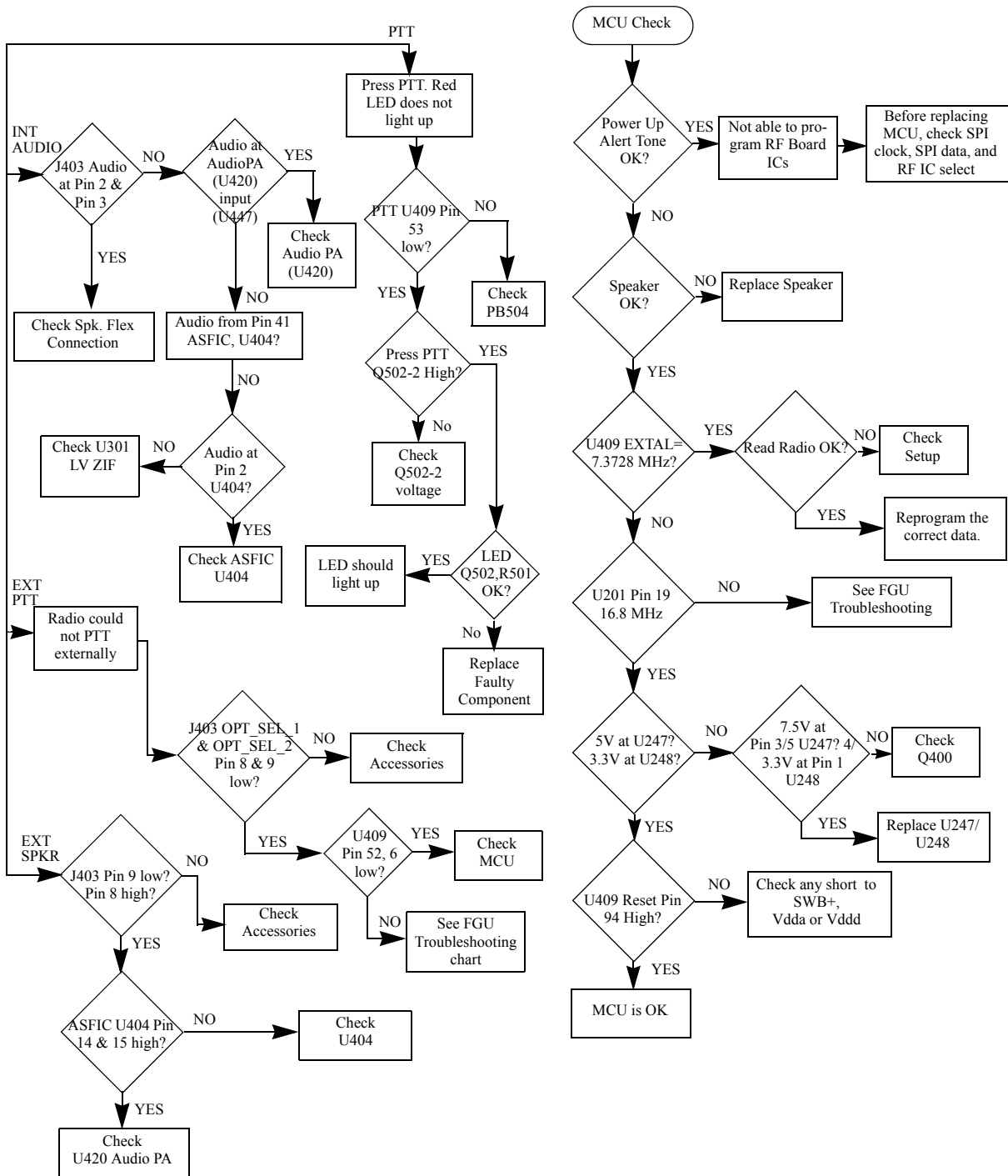

Troubleshooting Flow Chart for Controller

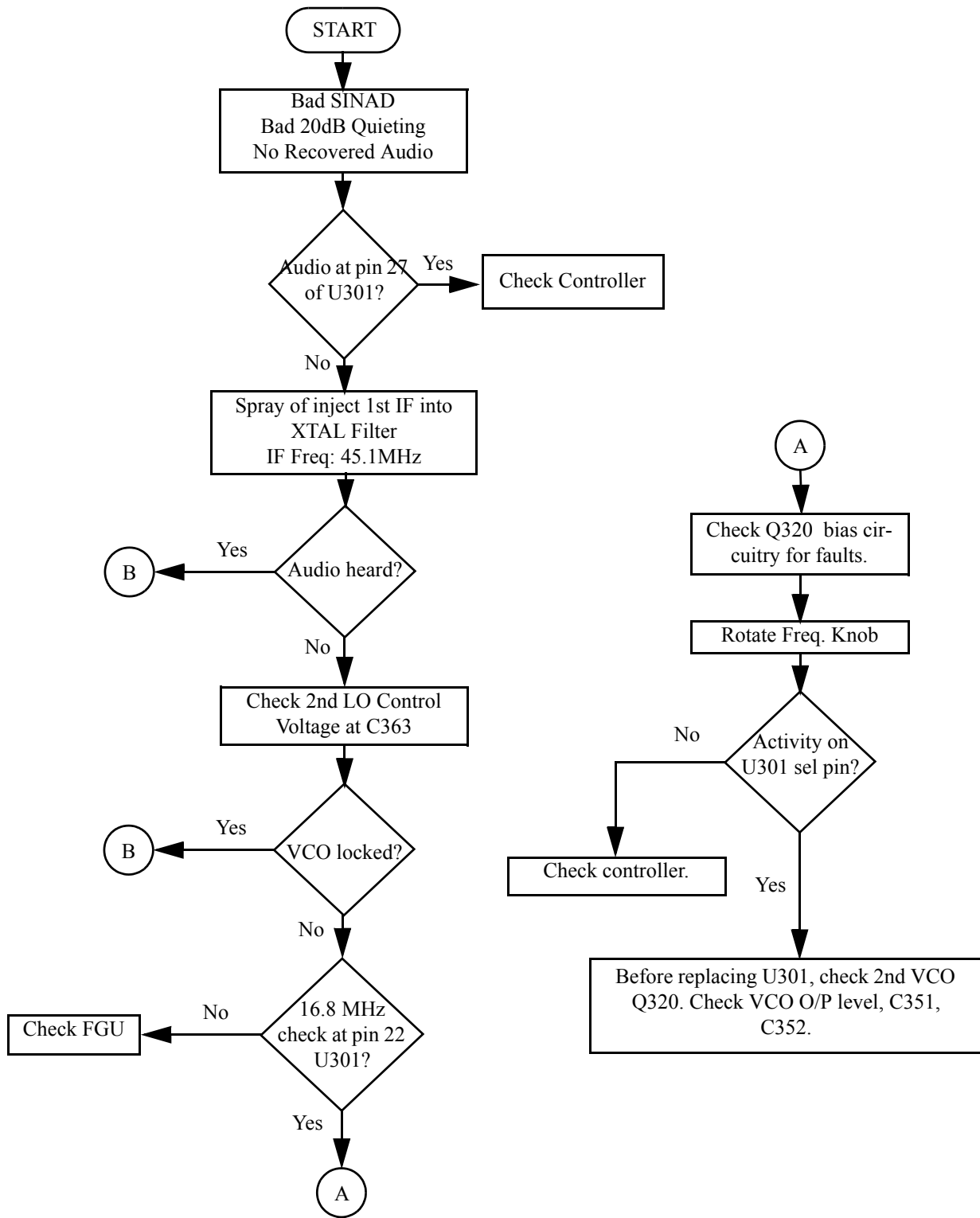

Troubleshooting Flow Chart for Receiver (Sheet 1 of 2)

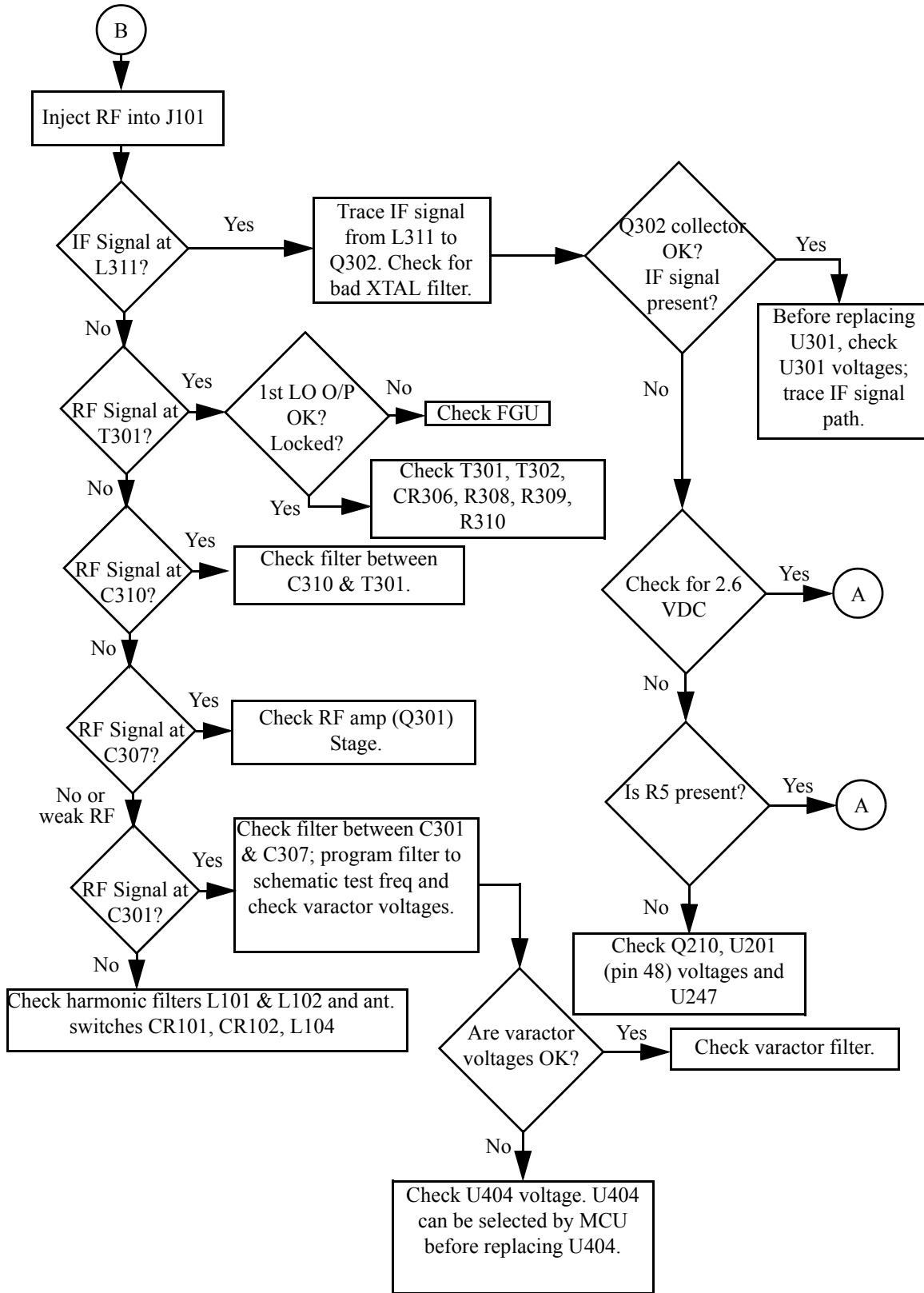

Troubleshooting Flow Chart for Receiver (Sheet 2 of 2)

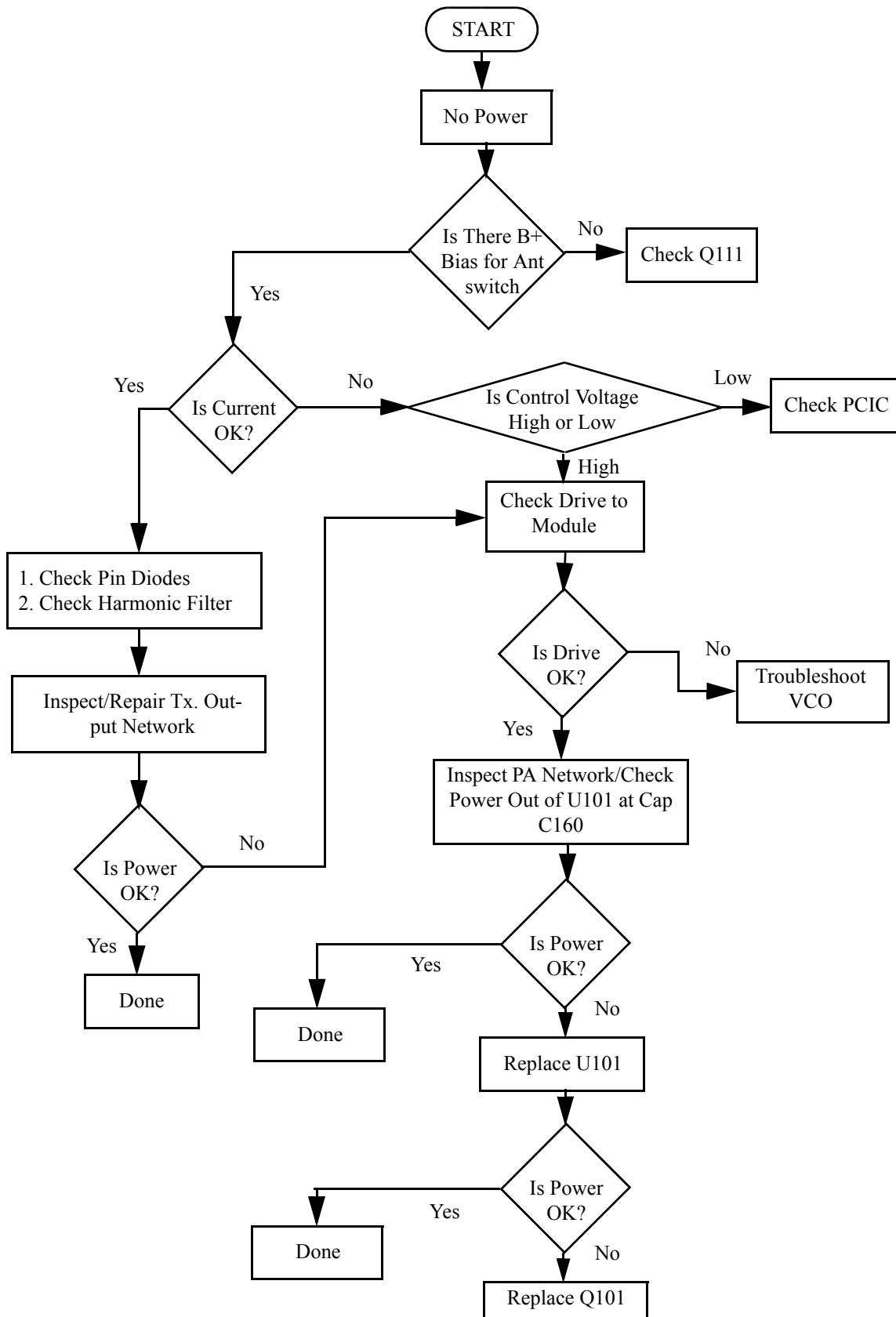

Troubleshooting Flow Chart for Transmitter

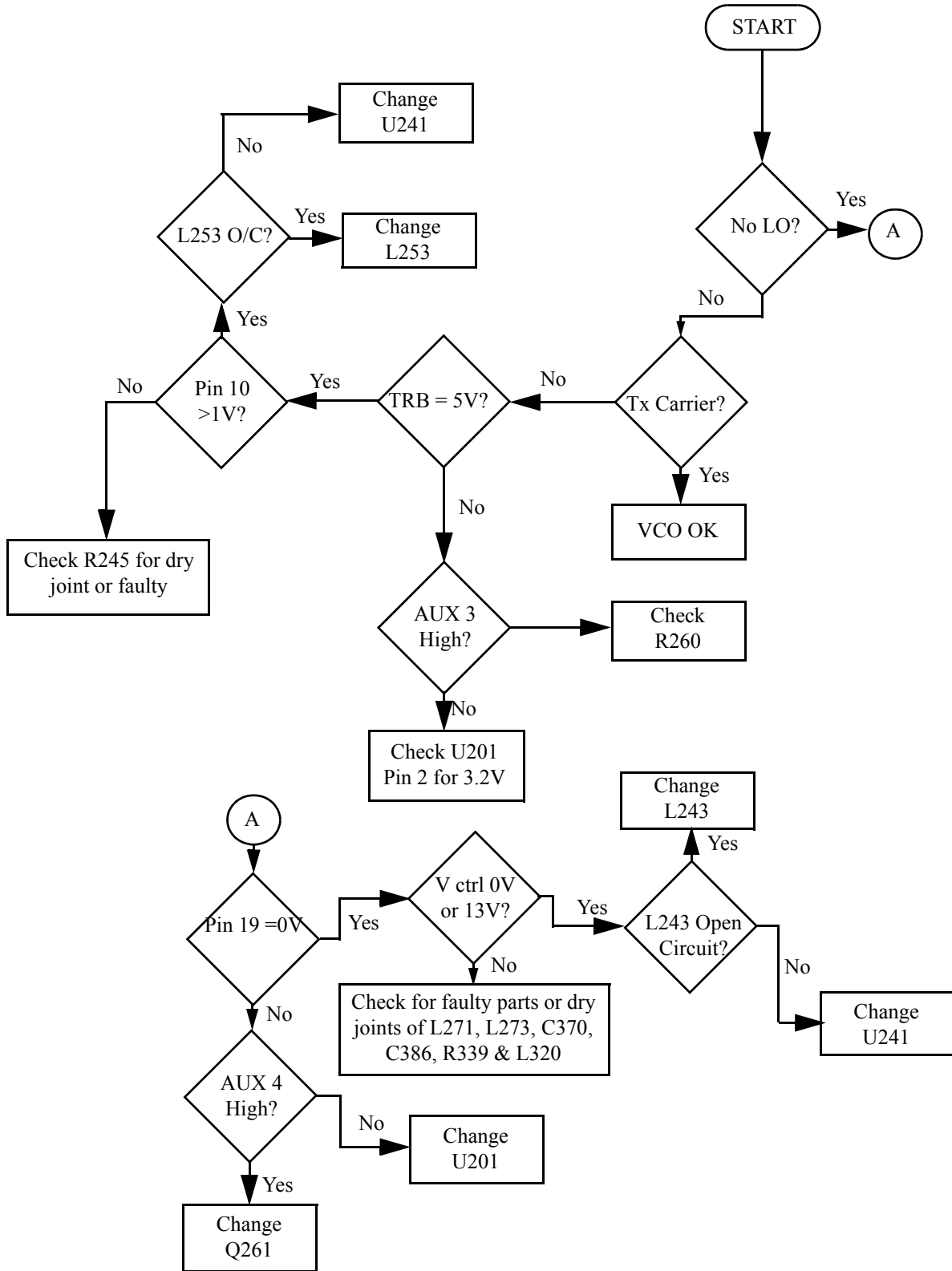

Troubleshooting Flow Chart for VCO

Section 5C

MODEL CHART AND TEST SPECIFICATIONS (450-527 MHZ)

1.0 Model Chart

GP Series, UHF Band 2, 450-527 MHz					
Model				Description	
AZH38SDC9AA2				GP328 Plus 450-527 MHz 4W 4 CH	
AZH38SDC9AA3				GP328 Plus 450-527 MHz 4W 16 CH	
AZH38SDH9AA6				GP338 Plus 450-527 MHz 4W 128 CH	
AZH38SDH9DU6				GP338 XLS 450-527 MHz 4W 160 CH	
Item				Description	
X				PMUE2049_	GP328 Plus Super Tanapa 450-527 MHz 4W 4CH
	X			PMUE1701_	GP328 Plus Super Tanapa 450-527 MHz 4W 16CH
		X		PMUE1702_	GP338 Plus Super Tanapa 450-527 MHz 4W 128CH
			X	PMUE1877_	GP338 XLS Super Tanapa 450-527 MHz 4W 160CH
X				PMUE2051_	GP328 Plus Tanapa 450-527 MHz 4W 4CH
	X			PMUE1705_	GP328 Plus Tanapa 450-527 MHz 4W 16CH
		X		PMUE1706_	GP338 Plus Tanapa 450-527 MHz 4W 128CH
			X	PMUE1879_	GP338 XLS Tanapa 450-527 MHz 4W 160CH
X				PMHE4027_	GP328 Plus B/C Kit 450-527 MHz 4W 4CH
	X			PMHE4004_	GP328 Plus B/C Kit 450-527 MHz 4W 16CH
		X		PMHE4011_	GP338 Plus B/C Kit 450-527 MHz 4W 128CH
			X	PMHE4021_	GP338 XLS B/C Kit 450-527 MHz 4W 160CH
X				PMHE4025_	GP328 Plus Front Housing Kit 4CH
	X			PMHE4002_	GP328 Plus Front Housing Kit 16CH
		X		PMHE4003_	GP338 Plus Front Housing Kit 128CH
			X	PMHE4019_	GP338 XLS Front Housing Kit 160CH
X	X	X	X	NAE6483_	Monopole (Whip) antenna (403-520 MHz)
X	X	X	X	PMAE4008_	Monopole (Whip) antenna (470-530 MHz)
X	X	X	X	PMAE4006_	UHF 9 cm antenna (465-495 MHz)
X	X	X	X	PMAE4007_	UHF 9 cm antenna (490-527 MHz)
X	X			6804022G48	GP328 Plus User Guide
		X		6804112J64	GP338 Plus User Guide
			X	6804114J01	GP338 XLS User Guide

x = Indicates one of each is required.

2.0 Specifications (for GP328 Plus)

General

	UHF	
Frequency:	450-527 MHz	
Channel Capacity:	GP328 Plus : 4/16 Channels	
Power Supply:	7.5 Volts ±20%	
Dimensions with Standard High Capacity Lithium Battery:	101.5mm x 55.5mm x 30.5mm	
Dimensions with Ultra High Capacity Lithium Battery:	101.5mm x 55.5mm x 35.5mm	
Weight: with Standard High Capacity Lithium Battery:	250 g	
Weight: with Ultra High Capacity Lithium Battery:	270 g	
Average Battery Life @ (5-5-90 Duty Cycle)	Low Power	High Power
Standard High Capacity Lithium Battery:	>10 hrs	>7 hrs
Ultra High Capacity Lithium Battery:	>14 hrs	>10 hrs
Sealing:	Meets MIL-STD-810-C,D & E and IPX4	
Shock:	Meets MIL-STD-810-C,D & E and TIA/EIA 603	
Vibration:	Meets MIL-STD-810-C,D & E and TIA/EIA 603	
Dust:	Meets MIL-STD-810-C,D & E and IP5X	
Humidity:	Meets MIL-STD-810-C,D & E and TIA/EIA 603	
FCC ID	AZ489FT4845	

Transmitter

	UHF	
RF Output Li Ion @ 7.5V:	Low 1W	High 4W
Frequency	450-527 MHz	
Channel Spacing	12.5/20/25 kHz	
Freq. Stability (-30°C to +60°C)	0.00025%	
Spurs/Harmonics:	-36 dBm < 1 GHz -30 dBm > 1 GHz	
Audio Response: (from 6 dB/oct. Pre-Emphasis, 300 to 3000Hz)	+1, -3 dB	
Audio Distortion: @ 1000 Hz, 60% Rated Max. Dev.	<5%	
FM Noise:	-40 dB	

Receiver

	UHF 12.5kHz	UHF 20/25kHz
Frequency:	450-527MHz	450-527MHz
Sensitivity 12dB EIA SINAD:	0.35 µV	0.35 µV
Adjacent Channel Selectivity ETS	-60 dB	-70 dB
Intermodulation ETS	-65 dB	-65 dB
Freq. Stability (-30°C to +60°C):	0.00025%	0.00025%
Spur Rejection:	-70 dB	-70 dB
Image Rejection:	-70 dB	-70 dB
Audio Output @ <5% Distortion	500 mW	500 mW

All specifications are subject to change without notice.

3.0 Specifications (for GP338 Plus/GP338 XLS)

General

	UHF	
Frequency:	450-527 MHz	
Channel Capacity:	GP338 Plus 128 Channels/GP338 XLS 160 Channels	
Power Supply:	7.5 Volts \pm 20%	
Dimensions with Standard High Capacity Lithium Battery:	101.5mm x 55.5mm x 33.0mm	
	with Ultra High Capacity Lithium Battery: 101.5mm x 55.5mm x 38.0mm	
Weight: with Standard High Capacity Lithium Battery:	265 g	
	with Ultra High Capacity Lithium Battery: 285 g	
Average Battery Life @ (5-5-90 Duty Cycle) Standard High Capacity Lithium Battery: Ultra High Capacity Lithium Battery:	Low Power	High Power
	>10 hrs	>7 hrs
	>14 hrs	>10 hrs
Sealing:	Meets MIL-STD-810-C,D & E and IPX4	
Shock:	Meets MIL-STD-810-C,D & E and TIA/EIA 603	
Vibration:	Meets MIL-STD-810-C,D & E and TIA/EIA 603	
Dust:	Meets MIL-STD-810-C,D & E and IP5X	
Humidity:	Meets MIL-STD-810-C,D & E and TIA/EIA 603	
FCC ID	AZ489FT4845	

Transmitter

	UHF	
RF Output Li Ion @ 7.5V:	Low 1W	High 4W
Frequency	450-527 MHz	
Channel Spacing	12.5/20/25 kHz	
Freq. Stability (-30°C to +60°C)	0.00025%	
Spurs/Harmonics:	-36 dBm < 1 GHz -30 dBm > 1 GHz	
Audio Response: (from 6 dB/oct. Pre-Emphasis, 300 to 3000Hz)	+1, -3 dB	
Audio Distortion: @ 1000 Hz, 60% Rated Max. Dev.	<5%	
FM Noise:	-40 dB	

Receiver

	UHF 12.5kHz	UHF 20/ 25kHz
Frequency:	450-527MHz	450-527MHz
Sensitivity 12dB EIA SINAD:	0.35 μ V	0.35 μ V
Adjacent Channel Selectivity ETS	-60 dB	-70 dB
Intermodulation ETS	-65 dB	-65 dB
Freq. Stability (-30°C to +60°C):	0.00025%	0.00025%
Spur Rejection:	-70 dB	-70 dB
Image Rejection:	-70 dB	-70 dB
Audio Output @ <5% Distortion	500 mW	500 mW

All specifications are subject to change without notice.

4.0 Transmitter

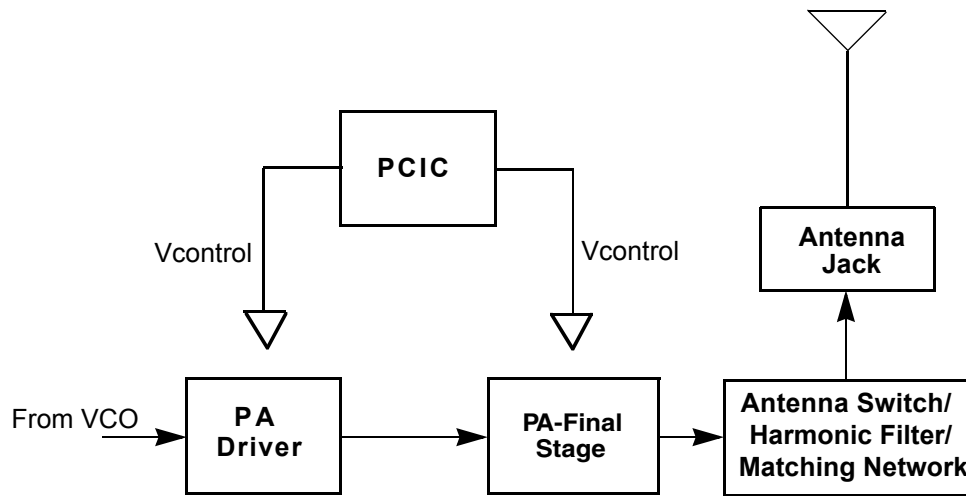

Figure 5-1: Transmitter Block Diagram

4.1 General

(Refer to Figure 5-1)

The UHF transmitter contains five basic circuits:

1. Power Amplifier
2. Antenna Switch
3. Harmonic Filter
4. Antenna Matching Network
5. Power Control Integrated Circuit (PCIC).

4.1.1 Power Amplifier

The power amplifier consists of two devices:

1. 9Z67 LDMOS driver IC (U101) and
2. PRF1507 LDMOS PA (Q110).

The 9Z67 LDMOS driver IC contains a 2 stage amplification with a supply voltage of 7.3V.

This RF power amplifier is capable of supplying an output power of 0.3W (pin 6 and 7) with an input signal of 2mW (3dBm) (pin16). The current drain would typically be 160mA while operating in the frequency range of 450-527MHz.

The PRF1507 LDMOS PA is capable of supplying an output power of 7W with an input signal of 0.3W. The current drain would typically be 1300mA while operating in the frequency range of 450-527MHz. The power output can be varied by changing the biasing voltage.

4.1.2 Antenna Switch

The antenna switch circuit consists of two PIN diodes (CR101 and CR102), a pi network (C107, L104 and C106), and two current limiting resistors (R101, R170). In the transmit mode, B+ at PCIC (U102) pin 23 will go low and turn on Q111 where a B+ bias is applied to the antenna switch circuit to bias the diodes "on". The shunt diode (CR102) shorts out the receiver port, and the pi network, which operates as a quarter wave transmission line, transforms the low impedance of the shunt diode to a high impedance at the input of the harmonic filter. In the receive mode, the diodes are both off, and hence, there exists a low attenuation path between the antenna and receiver ports.

4.1.3 Harmonic Filter

The harmonic filter consists of C104, L102, C103, L101 and C102. The design of the harmonic filter for UHF is that of a modified Zolotarev design. It has been optimized for efficiency of the power module. This type of filter has the advantage that it can give a greater attenuation in the stop-band for a given ripple level. The harmonic filter insertion loss is typically less than 1.2dB.

4.1.4 Antenna Matching Network

A matching network which is made up of L116 is used to match the antenna's impedance to the harmonic filter. This will optimize the performance of the transmitter and receiver into an antenna.

4.1.5 Power Control Integrated Circuit (PCIC)

The transmitter uses the Power Control IC (PCIC), U102 to regulate the power output of the radio. The current to the final stage of the power module is supplied through R101, which provides a voltage proportional to the current drain. This voltage is then fed back to the Automatic Level Control (ALC) within the PCIC to regulate the output power of the transmitter.

The PCIC has internal digital to analog converters (DACs) which provide the reference voltage of the control loop. The reference voltage level is programmable through the SPI line of the PCIC.

There are resistors and integrators within the PCIC, and external capacitors (C133, C134 and C135) in controlling the transmitter rising and falling time. These are necessary in reducing the power splatter into adjacent channels.

CR105 and its associated components are part of the temperature cut back circuitry. It senses the printed circuit board temperature around the transmitter circuits and output a DC voltage to the PCIC. If the DC voltage produced exceeds the set threshold in the PCIC, the transmitter output power will be reduced so as to reduce the transmitter temperature.

5.0 Receiver

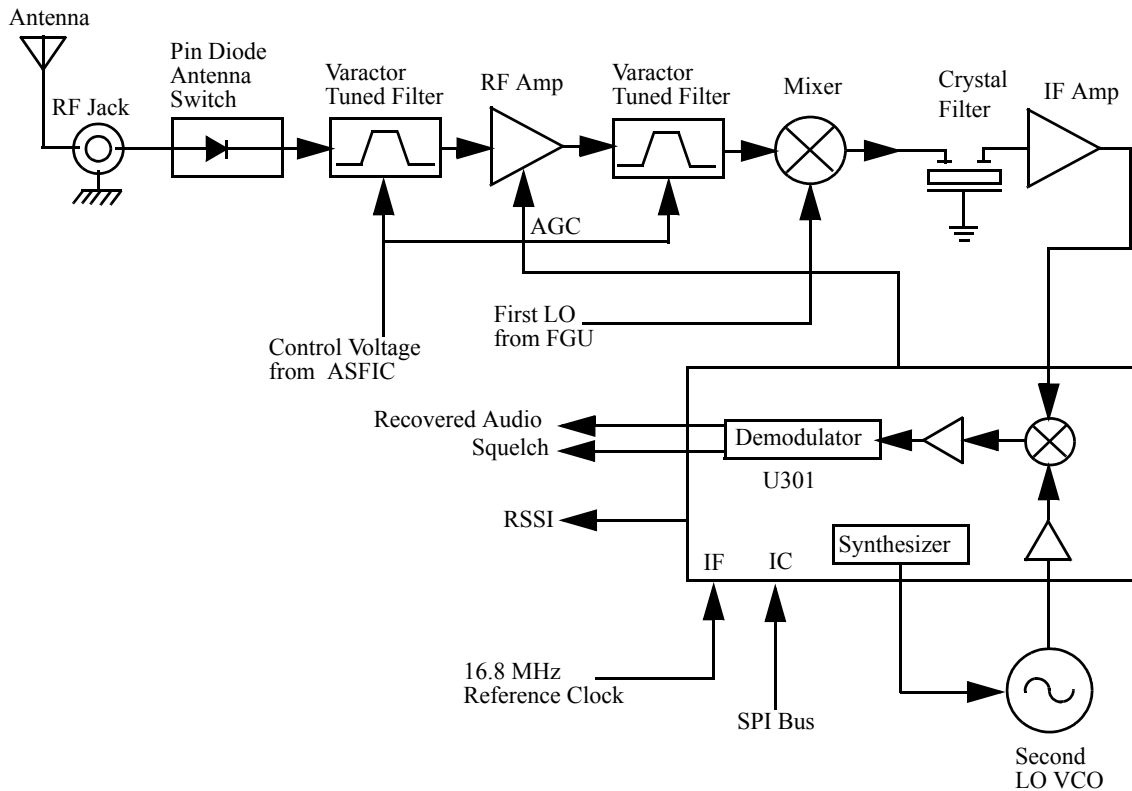

Figure 5-2: UHF Receiver Block Diagram

5.1 Receiver Front-End

(Refer to *UHF Band 2 Receiver Front End Schematic Diagram* on page 5C-22 and *UHF Band 2 Transmitter Schematic Diagram* on page 5C-26)

The RF signal is received by the antenna and applied to a low-pass filter. For UHF, the filter consists of L101, L102, C102, C103, C104. The filtered RF signal is passed through the antenna switch. The antenna switch circuit consists of two PIN diodes (CR101 and CR102) and a pi network (C106, L104 and C107). The signal is then applied to a varactor tuned bandpass filter. The UHF bandpass filter comprises of L301, L302, C302, C303, C304, CR301 and CR302. The bandpass filter is tuned by applying a control voltage to the varactor diodes (CR301 and CR302) in the filter.

The bandpass filter is electronically tuned by the DACRx from IC404 which is controlled by the microprocessor. Depending on the carrier frequency, the DACRx will supply the tuned voltage to the varactor diodes in the filter. Wideband operation of the filter is achieved by shifting the bandpass filter across the band.

The output of the bandpass filter is coupled to the RF amplifier transistor Q301 via C307. After being amplified by the RF amplifier, the RF signal is further filtered by a second varactor tuned bandpass filter, consisting of L306, L307, C313, C317, CR304 and CR305.

Both the pre and post-RF amplifier varactor tuned filters have similar responses. The 3 dB bandwidth of the filter is about 50 MHz. This enables the filters to be electronically controlled by using a single control voltage which is DACRx.

The output of the post-RF amplifier filter which is connected to the passive double balanced mixer consists of T301, T302 and CR306. Matching of the filter to the mixer is provided by C381. After mixing with the first LO signal from the voltage controlled oscillator (VCO) using low side injection, the RF signal is down-converted to the 45.1 MHz IF signal.

The IF signal coming out of the mixer is transferred to the crystal filter (FL301) through a resistor pad and a diplexer (C322 and L310). Matching to the input of the crystal filter is provided by C324 and L311. The crystal filter provides the necessary selectivity and intermodulation protection.

5.2 Receiver Back-End

(Refer to *UHF Band 2 Receiver Back End Schematic Diagram* on page 5C-23)

The output of crystal filter FL301 is matched to the input of IF amplifier transistor Q302 by components R352 and C325. Voltage supply to the IF amplifier is taken from the receive 5 volts (R5). The IF amplifier provides a gain of about 7dB. The amplified IF signal is then coupled into U301 (pin 3) via C330, C338 and L330 which provides the matching for the IF amplifier and U301.

The IF signal applied to pin 3 of U301 is amplified, down-converted, filtered, and demodulated, to produce the recovered audio at pin 27 of U301. This IF IC is electronically programmable, and the amount of filtering (which is dependent on the radio channel spacing) is controlled by the microprocessor. Additional filtering, once externally provided by the conventional ceramic filters, is replaced by internal filters in the IF module (U301).

The IF IC uses a type of direct conversion process, whereby the externally generated second LO frequency is divided by two in U301 so that it is very close to the first IF frequency. The IF IC (U301) synthesizes the second LO and phase-locks the VCO to track the first IF frequency. The second LO is designed to oscillate at twice the first IF frequency because of the divide-by-two function in the IF IC.

In the absence of an IF signal, the VCO will “search” for a frequency, or its frequency will vary close to twice the IF frequency. When an IF signal is received, the VCO will lock onto the IF signal. The second LO/VCO is a Colpitts oscillator built around transistor Q320. The VCO has a varactor diode, CR310, to adjust the VCO frequency. The control signal for the varactor is derived from a loop filter consisting of C362, C363, C364, R320 and R321.

The IF IC (U301) also performs several other functions. It provides a received signal-strength indicator (RSSI) and a squelch output. The RSSI is a dc voltage monitored by the microprocessor, and used as a peak indicator during the bench tuning of the receiver front-end varactor filter. The RSSI voltage is also used to control the automatic gain control (AGC) circuit at the front-end.

The demodulated signal on pin 27 of U301 is also used for squelch control. The signal is routed to U404 (ASFIC) where squelch signal shaping and detection takes place. The demodulated audio signal is also routed to U404 for processing before going to the audio amplifier for amplification.

5.3 Automatic Gain Control Circuit

(Refer to *UHF Band 2 Receiver Front End Schematic Diagram* on page 5C-22)

The front end automatic gain control circuit is to provide automatic gain reduction of the front end RF amplifier via feedback. This action is necessary to prevent overloading of back end circuits. This is achieved by drawing some of the output power from the RF amplifier's output. At high radio frequencies, capacitor C331 provides the low impedance path to ground for this purpose. CR308 is a PIN diode used for switching the path on or off. A certain amount of forward biasing current is needed to turn the PIN diode on. Transistor Q315 provides this current where upon saturation, current will flow via R347, PIN diode, collector and emitter of Q315 and R319 before going to ground. Q315 is an NPN transistor used for switching here. Maximum current flowing through the PIN is mainly limited by the resistor R319.

Radio signal strength indicator, RSSI, a voltage signal, is used to drive Q315 to saturation hence turning it on. RSSI is produced by U301 and is proportional to the gain of the RF amplifier and the input RF signal power to the radio.

Resistor network at the input to the base of Q315 is scaled to turn on Q315, hence activating the AGC, at certain RSSI levels. In order to turn on Q315, the voltage across the transistor's base to ground must be greater or equal to the voltage across R319, plus the base-emitter voltage (V_{be}) present at Q315. The resistor network with thermistor RT300 is capable of providing temperature compensation to the AGC circuit, as RSSI generated by U301 is lower at cold temperatures compared to normal operation at room temperature. Resistor R300 and capacitor C397 form an R-C network used to dampen any transient instability while the AGC is turning on.

6.0 Frequency Generation Circuitry

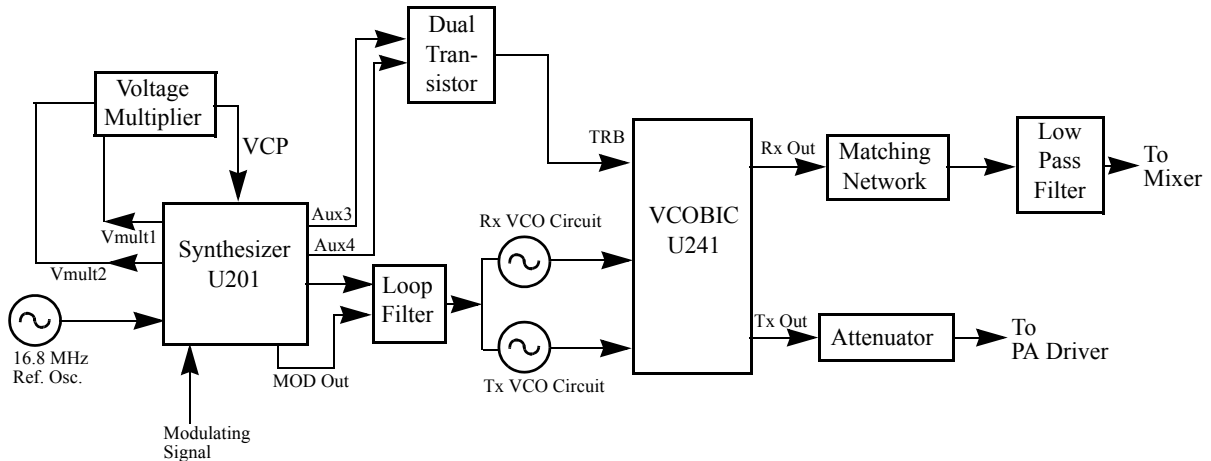

Figure 5-3: Frequency Generation Unit Block Diagram

The Frequency Generation Circuitry is composed of two main ICs, the Fractional-N synthesizer (U201), and the VCO/Buffer IC (U241). Designed in conjunction to maximize compatibility, the two ICs provide many of the functions that normally would require additional circuitry. The synthesizer block diagram illustrates the interconnect and support circuitry used in the region. Refer to the relevant schematics for the reference designators.

The synthesizer is powered by regulated 5V and 3.3V which come from U247 and U248 respectively. The synthesizer in turn generates a superfiltered 4.5V which powers U241.

In addition to the VCO, the synthesizer must interface with the logic and ASFIC circuitry.

Programming for the synthesizer is accomplished through the data, clock and chip select lines from the microprocessor. A 3.3V dc signal from synthesizer lock detect line indicates to the microprocessor that the synthesizer is locked.

Transmit modulation from the ASFIC is supplied to pin10 of U201. Internally the audio is digitized by the Fractional-N and applied to the loop divider to provide the low-port modulation. The audio runs through an internal attenuator for modulation balancing purposes before going out to the VCO.

6.1 Synthesizer

(Refer to *UHF Band 2 Synthesizer Schematic Diagram* on page 5C-24)

The Fractional-N Synthesizer uses a 16.8MHz crystal (FL201) to provide a reference for the system. The LVFractN IC (U201) further divides this to 2.1MHz, 2.225MHz, and 2.4MHz as reference frequencies. Together with C206, C207, C208, R204 and CR203, they build up the reference oscillator which is capable of 2.5ppm stability over temperatures of -30 to 85°C. It also provides 16.8MHz at pin 19 of U201 to be used by ASFIC and LVZIF.

The loop filter which consist of C231, C232, C233, R231, R232 and R233 provides the necessary dc steering voltage for the VCO and determines the amount of noise and spur passing through .

In achieving fast locking for the synthesizer, an internal adapt charge pump provides higher current at pin 45 of U201 to put synthesizer within the lock range. The required frequency is then locked by normal mode charge pump at pin 43 .

Both the normal and adapt charge pumps get their supply from the capacitive voltage multiplier which is made up of C258, C259, C228, triple diode CR201 and level shifters U210 and U211. Two 3.3V square waves (180 deg out of phase) are first shifted to 5V, then along with regulated 5V , put through arrays of diodes and capacitors to build up 13.3V at pin 47 of U201.

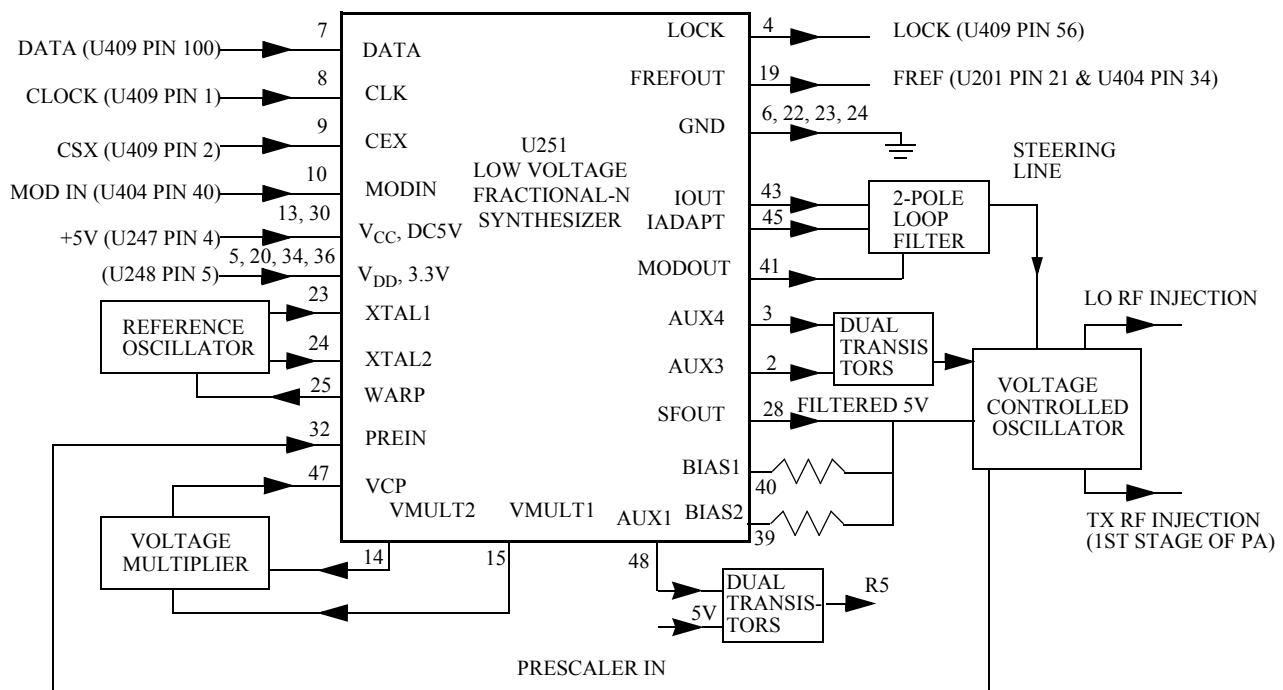

Figure 5-4: Synthesizer Block Diagram

6.2 VCO - Voltage Controlled Oscillator

(Refer to UHF Band 2 Voltage Controlled Oscillator Schematic Diagram on page 5C-25)

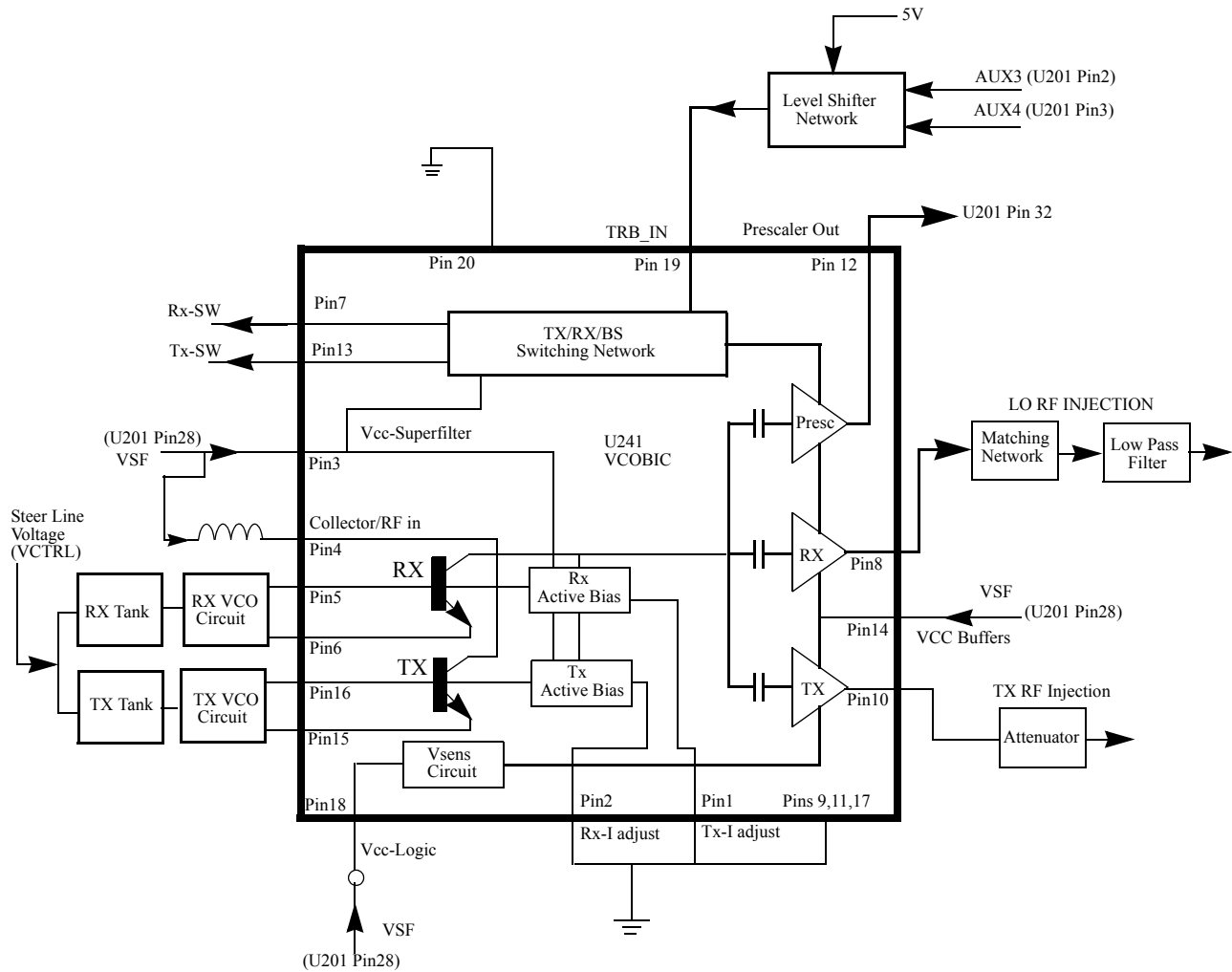

Figure 5-5: VCO Block Diagram

The VCOBIC (U241) in conjunction with the Fractional-N synthesizer (U201) generates RF in both the receive and the transmit modes of operation. The TRB line (U241 pin 19) determines which oscillator and buffer will be enabled. A sample of the RF signal from the enabled oscillator is routed from U241 pin 12, through a low pass filter, to the prescaler input (U201 pin 32). After frequency comparison in the synthesizer, a resultant CONTROL VOLTAGE is received at the VCO. This voltage is a DC voltage between 3.5V and 9.5V when the PLL is locked on frequency.

The VCOBIC(U241) is operated at 4.54 V (VSF) and Fractional-N synthesizer (U201) at 3.3V. This difference in operating voltage requires a level shifter consisting of Q260 and Q261 on the TRB line. The operation logic is shown in Table 5-1.

Table 5-1: Level Shifter Logic

Desired Mode	AUX 4	AUX 3	TRB
Tx	Low	High (@3.2V)	High (@4.8V)
Rx	High	Low	Low
Battery Saver	Low	Low	Hi-Z/Float (@2.5V)

In the receive mode, U241 pin 19 is low or grounded. This activates the receive VCO by enabling the receive oscillator and the receive buffer of U241. The RF signal at U241 pin 8 is run through a matching network. The resulting RF signal is the LO RF INJECTION and it is applied to the mixer at T302 (refer to *UHF Band 2 Receiver Front End Schematic Diagram* on page 5C-22).

During the transmit condition, when PTT is depressed, five volts is applied to U241 pin 19. This activates the transmit VCO by enabling the transmit oscillator and the transmit buffer of U241. The RF signal at U241 pin 10 is injected into the input of the PA module (U101 pin16). This RF signal is the TX RF INJECTION. Also in transmit mode, the audio signal to be frequency modulated onto the carrier is received through the U201 pin 41.

When a high impedance is applied to U241 pin19, the VCO is operating in BATTERY SAVER mode. In this case, both the receive and transmit oscillators as well as the receive transmit and prescaler buffer are turned off.

7.0 Notes For All Schematics and Circuit Boards

* Component is frequency sensitive. Refer to the Electrical Parts List for value and usage.

1. Unless otherwise stated, resistances are in Ohms ($k = 1000$), and capacitances are in picofarads (pF) or microfarads (μF).
2. DC voltages are measured from point indicated to chassis ground using a Motorola DC multimeter or equivalent. Transmitter measurements should be made with a $1.2 \mu H$ choke in series with the voltage probe to prevent circuit loading.
3. Reference Designators are assigned in the following manner:

100 Series	=	Transmitter
200 Series	=	Frequency Generation
300 Series	=	Receiver
400/500 Series	=	Controller
600 Series	=	Keypad Board
4. Interconnect Tie Point Legend:

UNSWB+	=	Unswitch Battery Voltage (7.5V)
SWB+	=	Switch Battery Voltage (7.5V)
R5	=	Receiver Five Volts
CLK	=	Clock
Vdda	=	Regulated 3.3 Volts (for analog)
Vddd	=	Regulated 3.3 Volts (for digital)
CSX	=	Chip Select Line (not for LVZIF)
SYN	=	Synthesizer
DACRX	=	Digital to Analog Voltage (For Receiver Front End Filter)
VSF	=	Voltage Super Filtered (5 volts)
VR	=	Voltage Regulator

6-LAYER CIRCUIT BOARD DETAIL VIEWING COPPER STEPS IN PROPER LAYER SEQUENCE

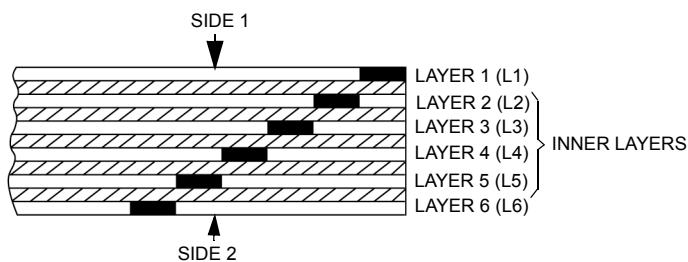

THIS PAGE INTENTIONALLY LEFT BLANK

8.0 Circuit Board/Schematic Diagrams and Parts List

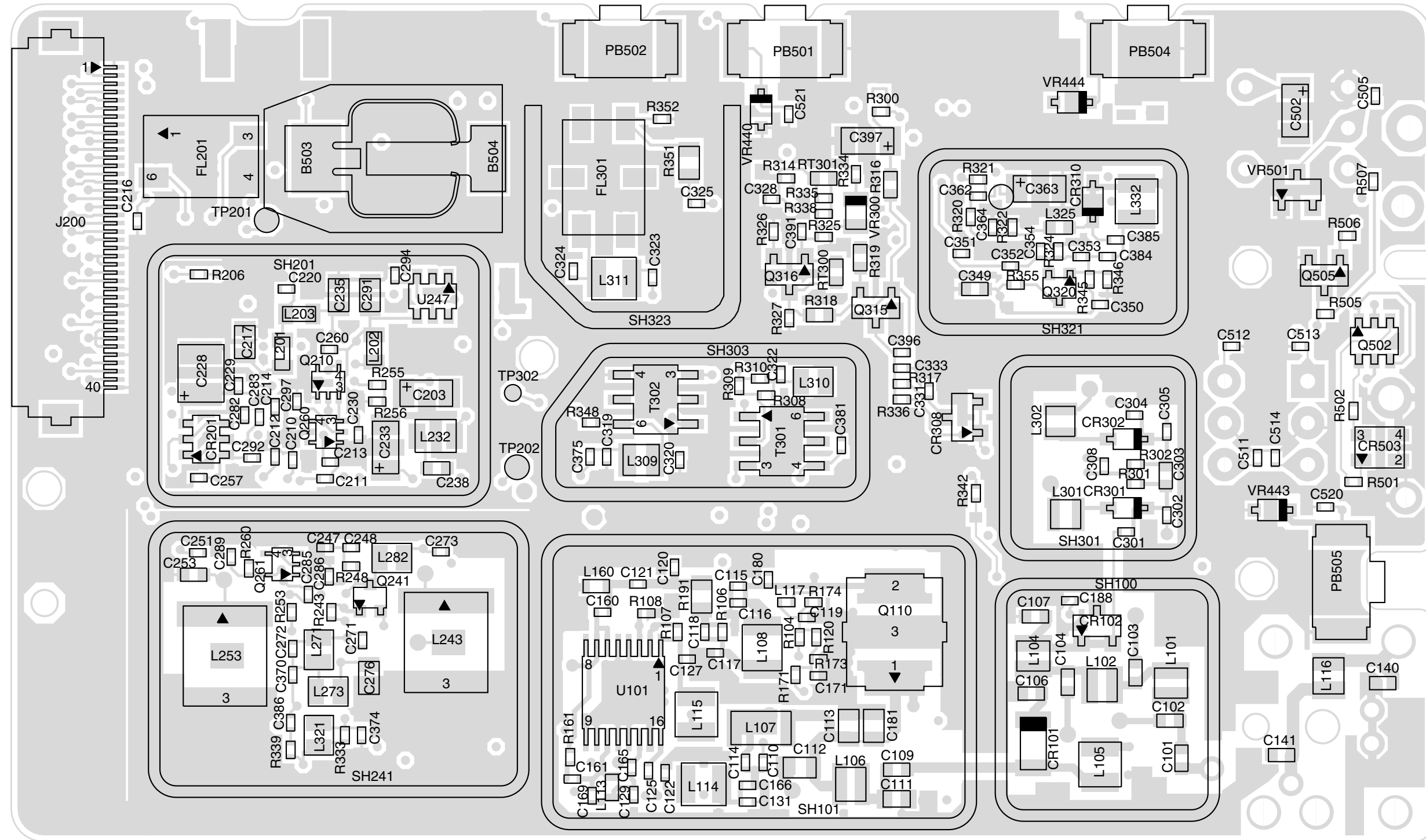

**UHF Band 2 (450-527MHz) Main Board Top Side
PCB No. 8404102G03/G04/G05**

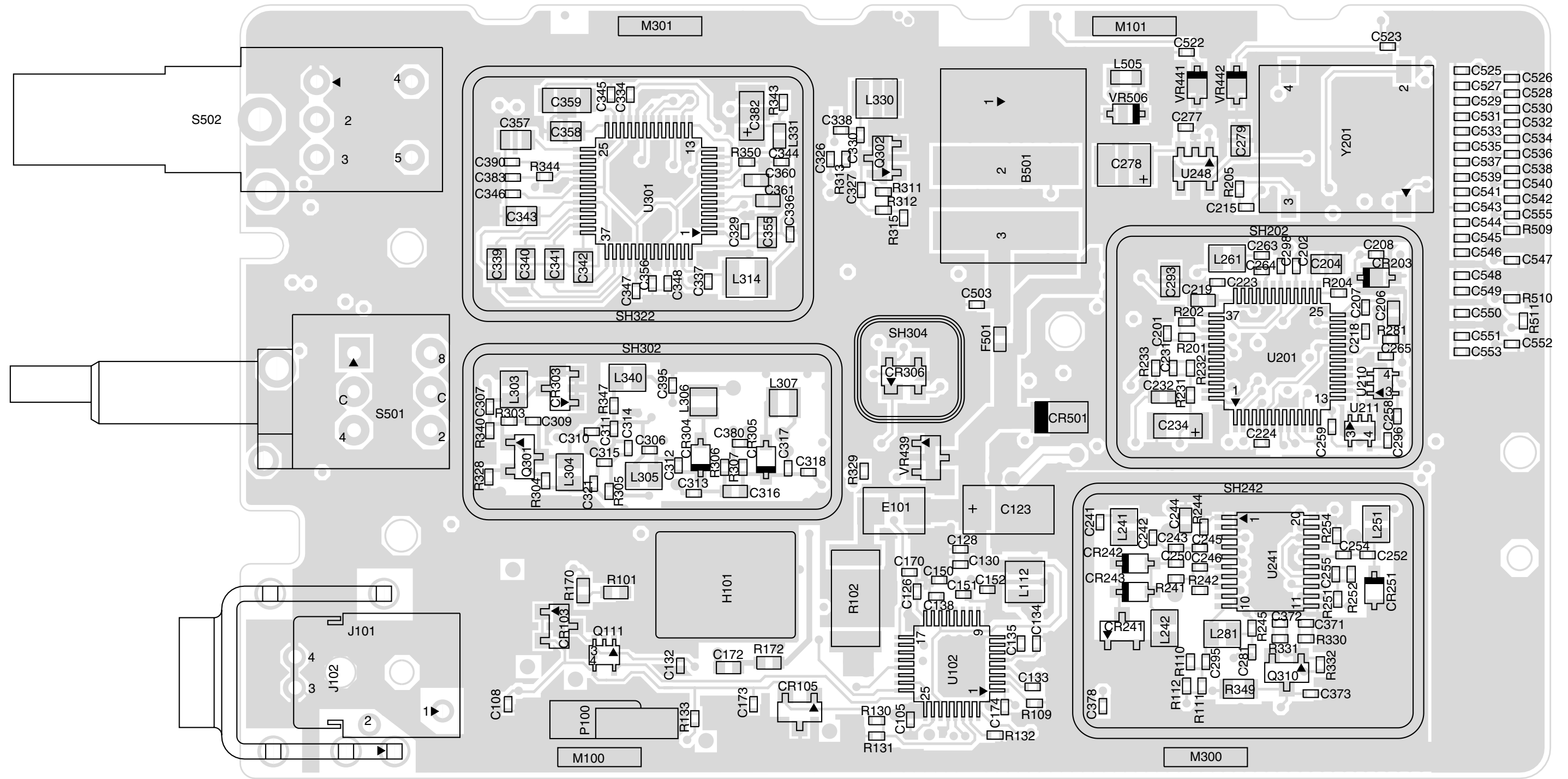

**UHF Band 2 (450-527MHz) Main Board Bottom Side
PCB No. 8404102G03/G04/G05**

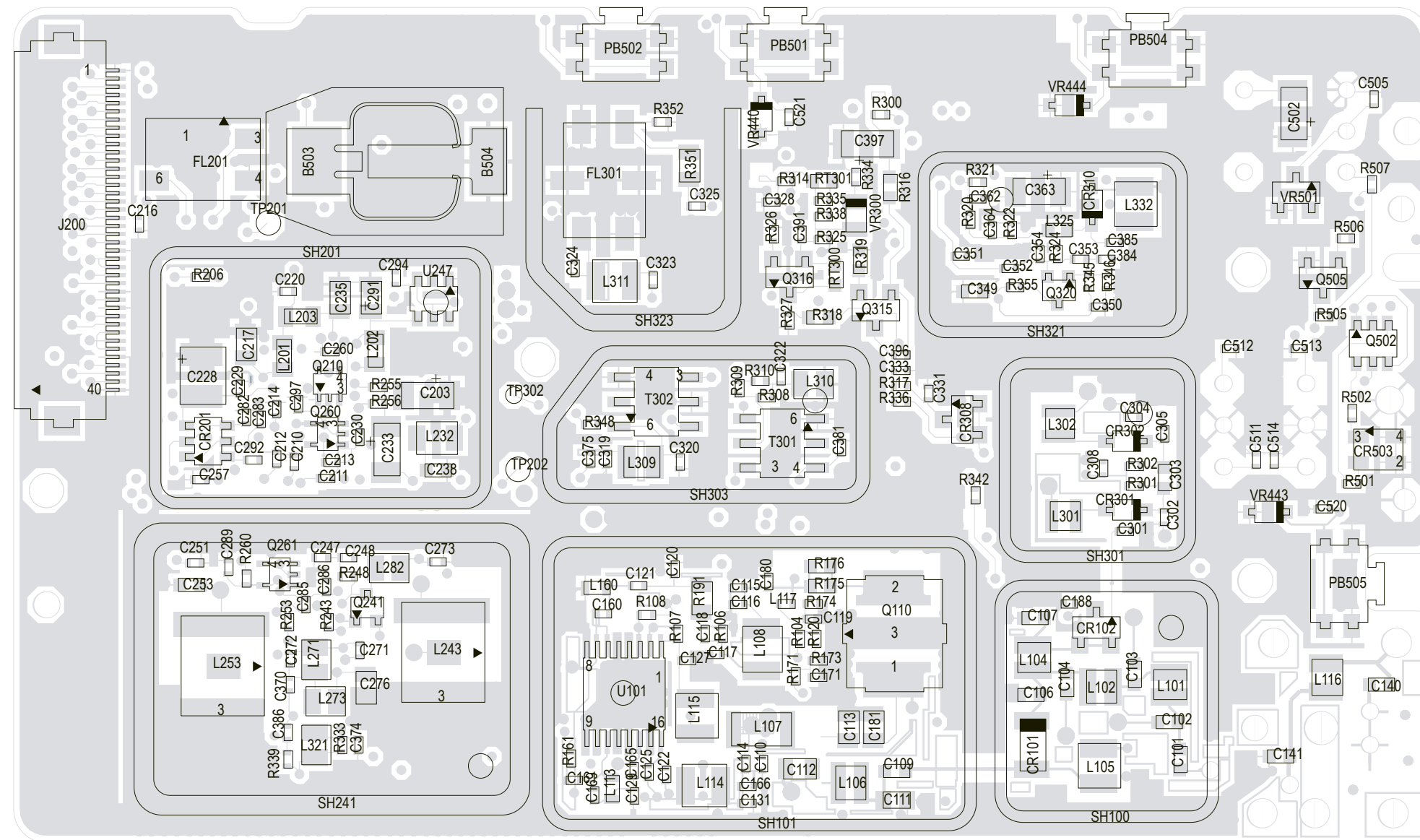

ZMY0131026-O

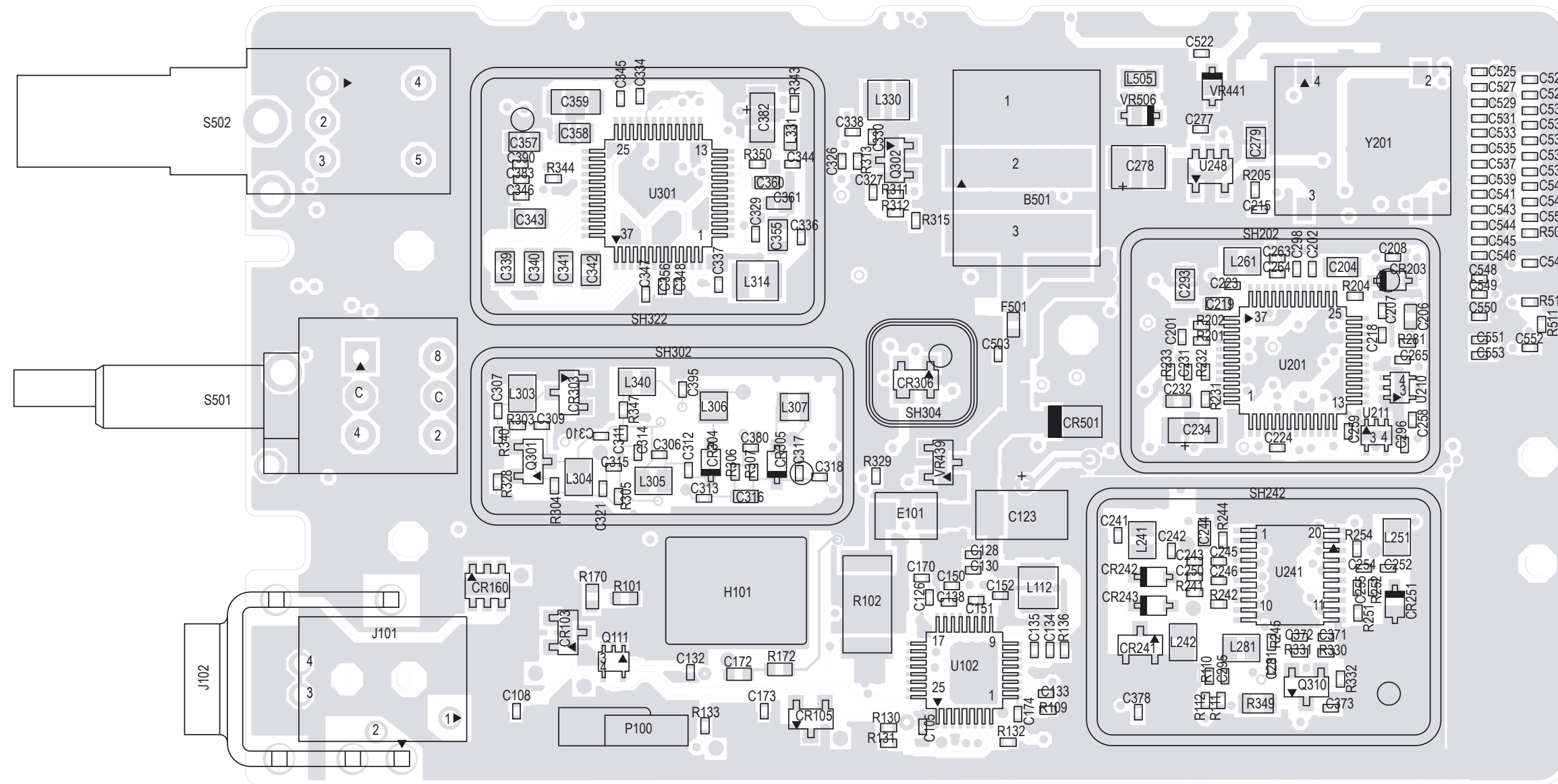

ZMY0131027-O

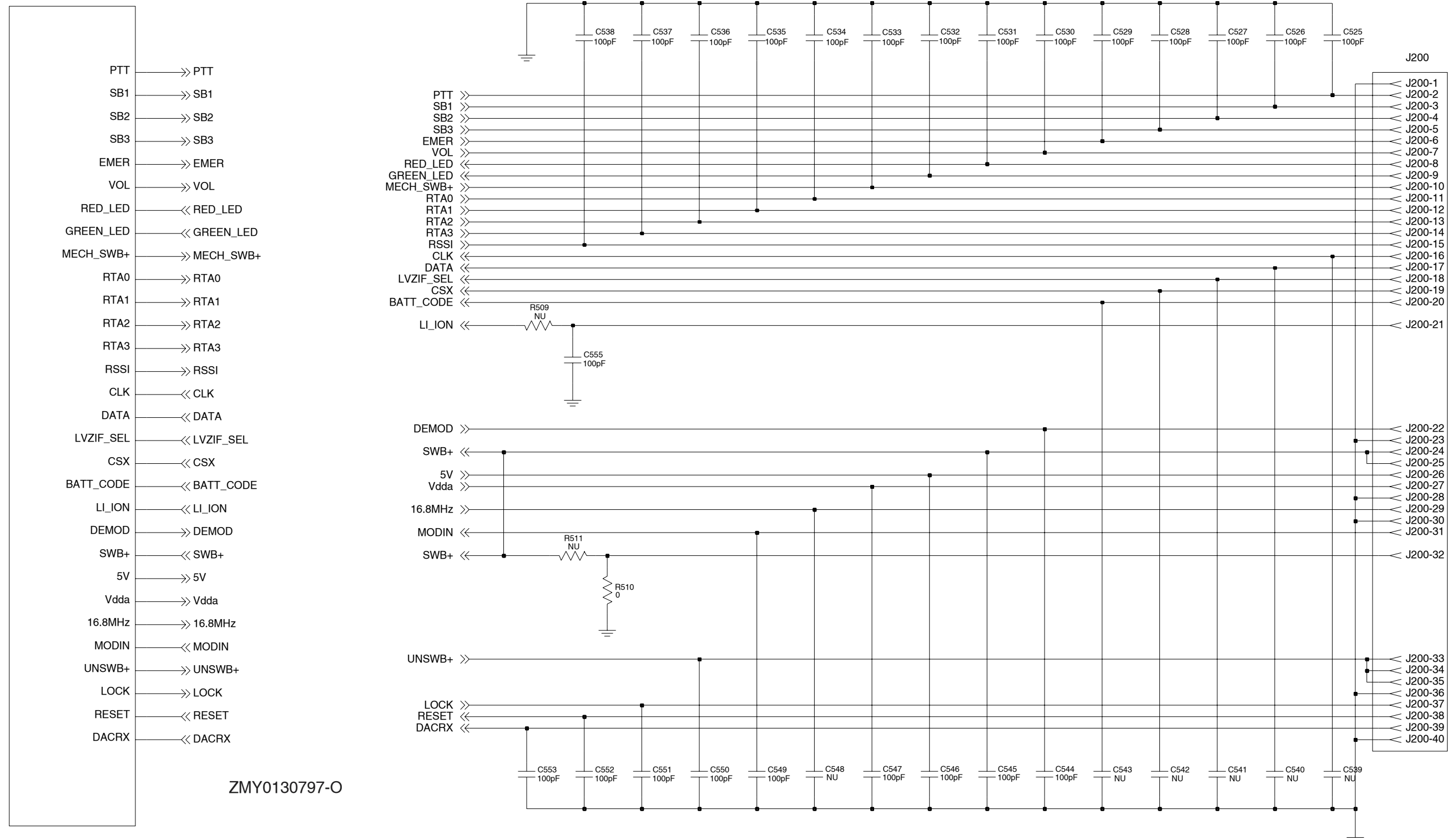

ZMY0130797-O

UHF Band 2 Controls And Switches Schematic Diagram (sheet 1 of 2)

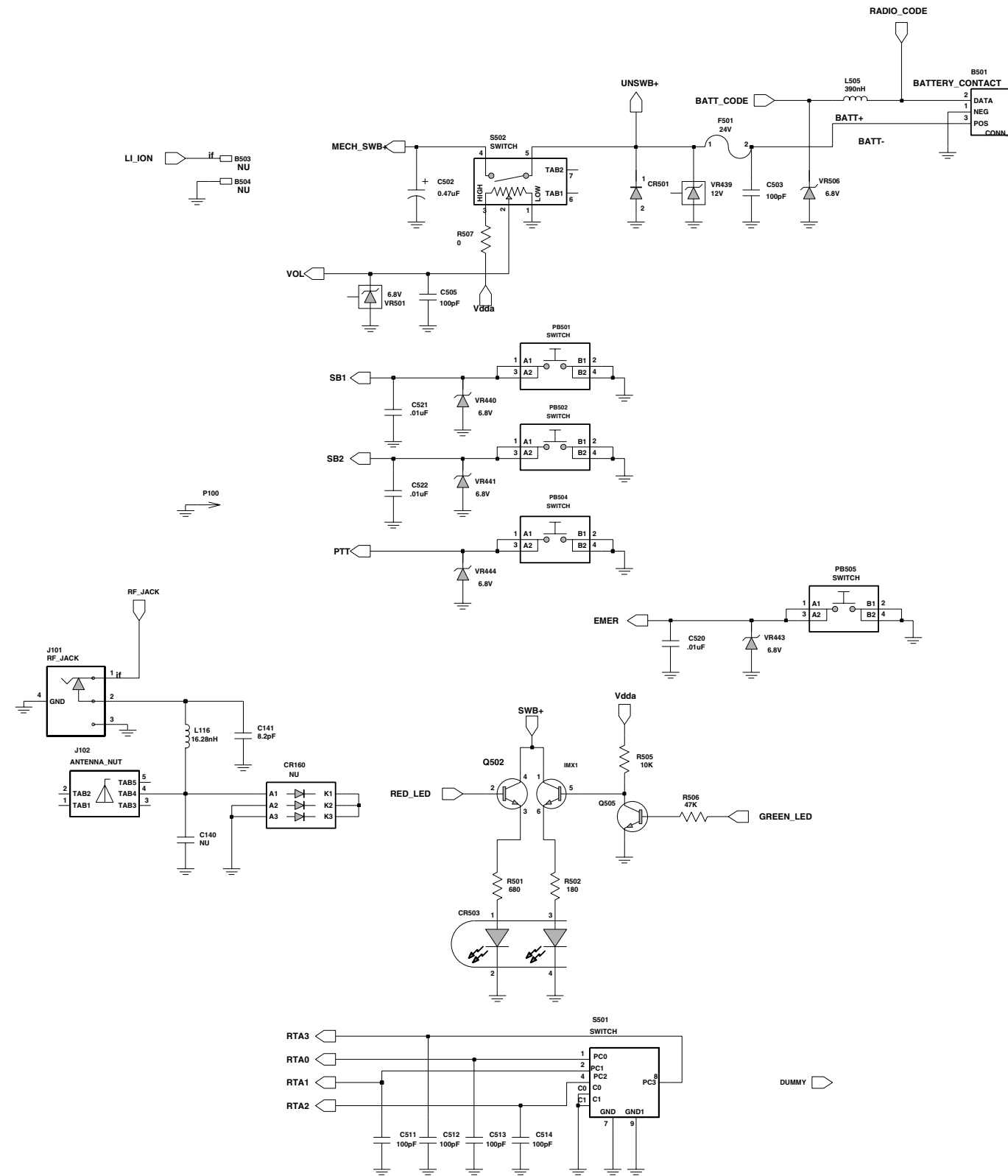

UHF Band 2 Controls And Switches Schematic Diagram (sheet 2 of 2)

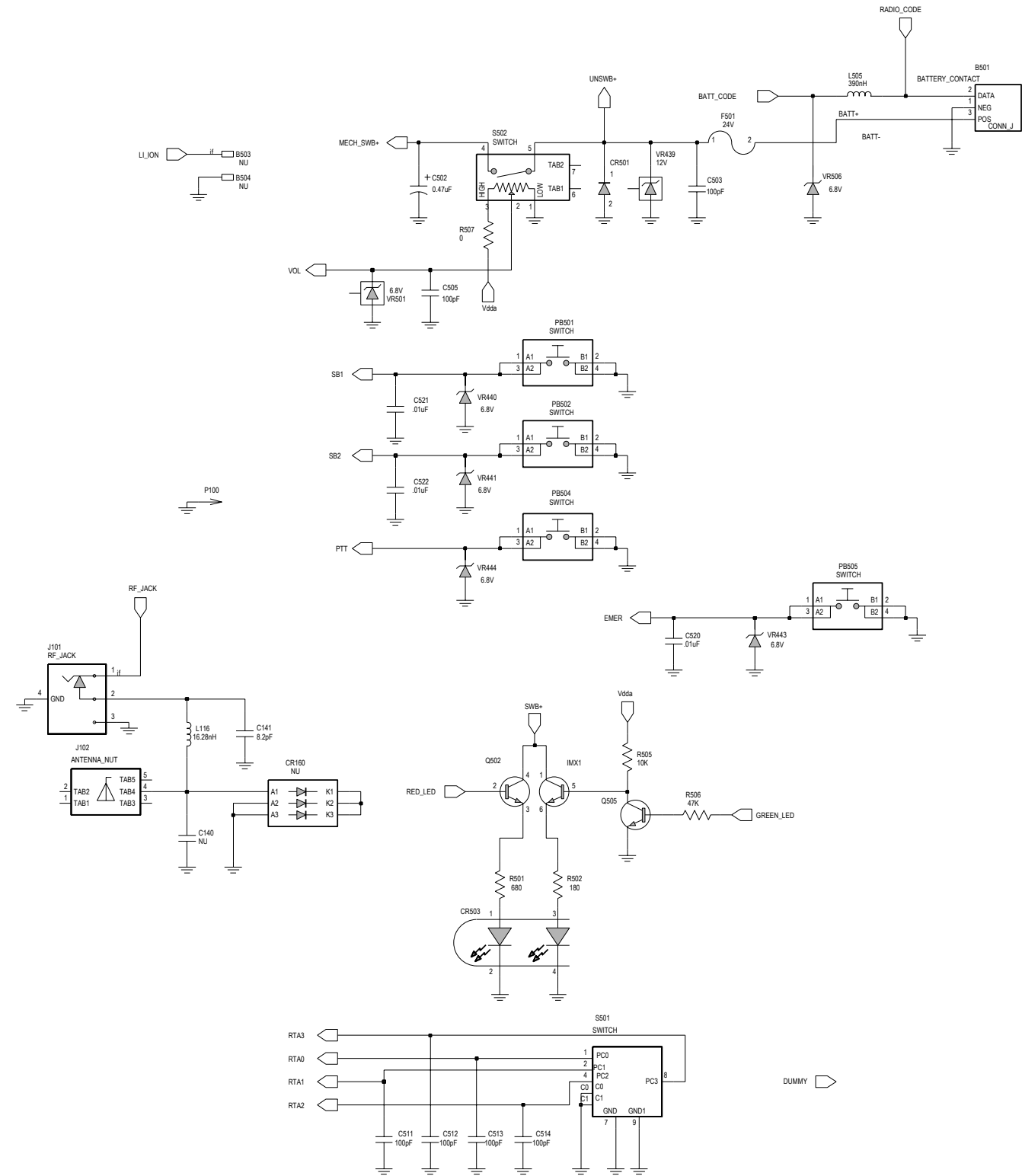

ZMY01301002-0

**UHF Band 2 Controls And Switches Schematic Diagram
(sheet 2 of 2 for 8404102G07 PCB)**

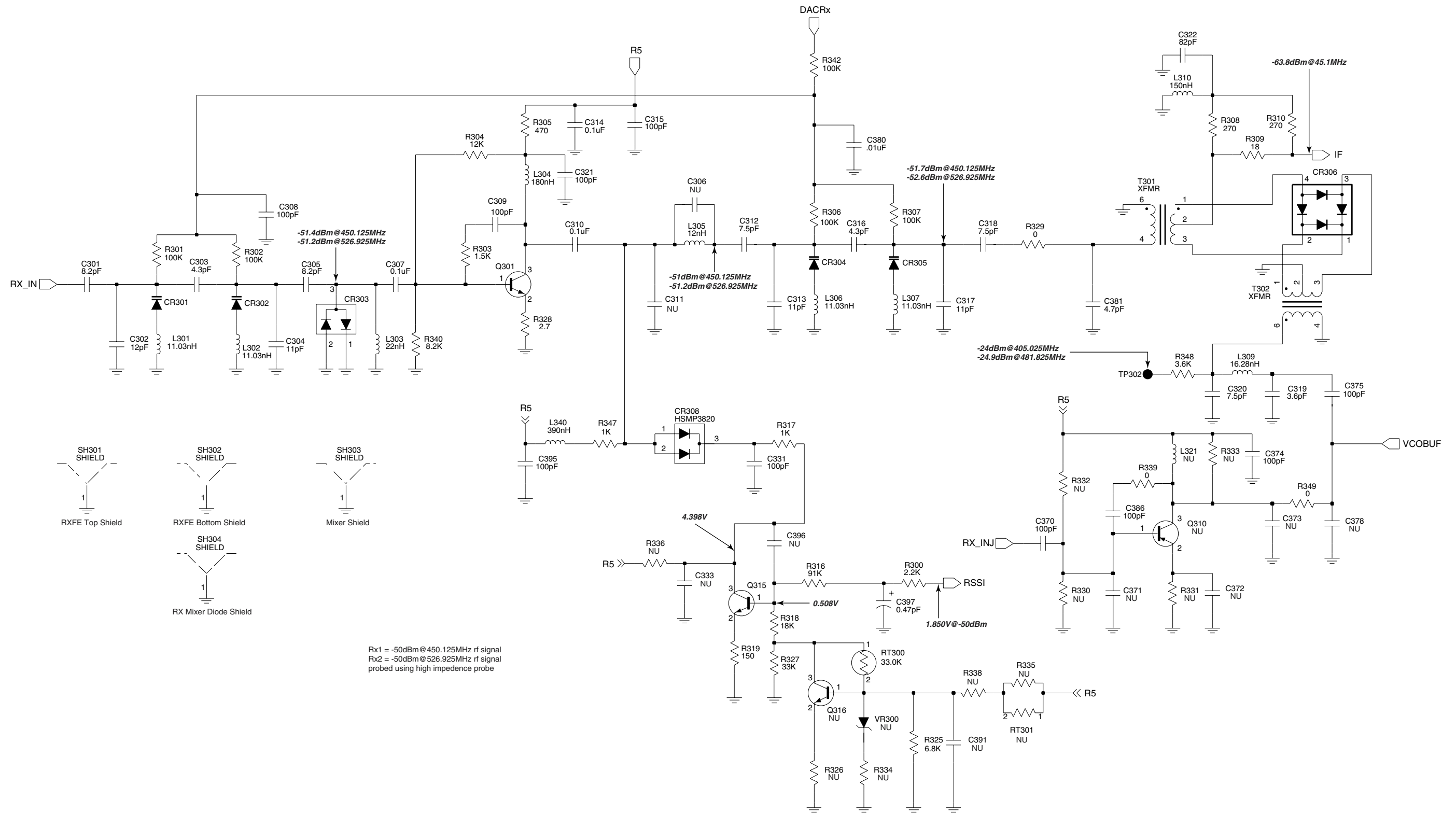

UHF Band 2 Receiver Front End Schematic Diagram

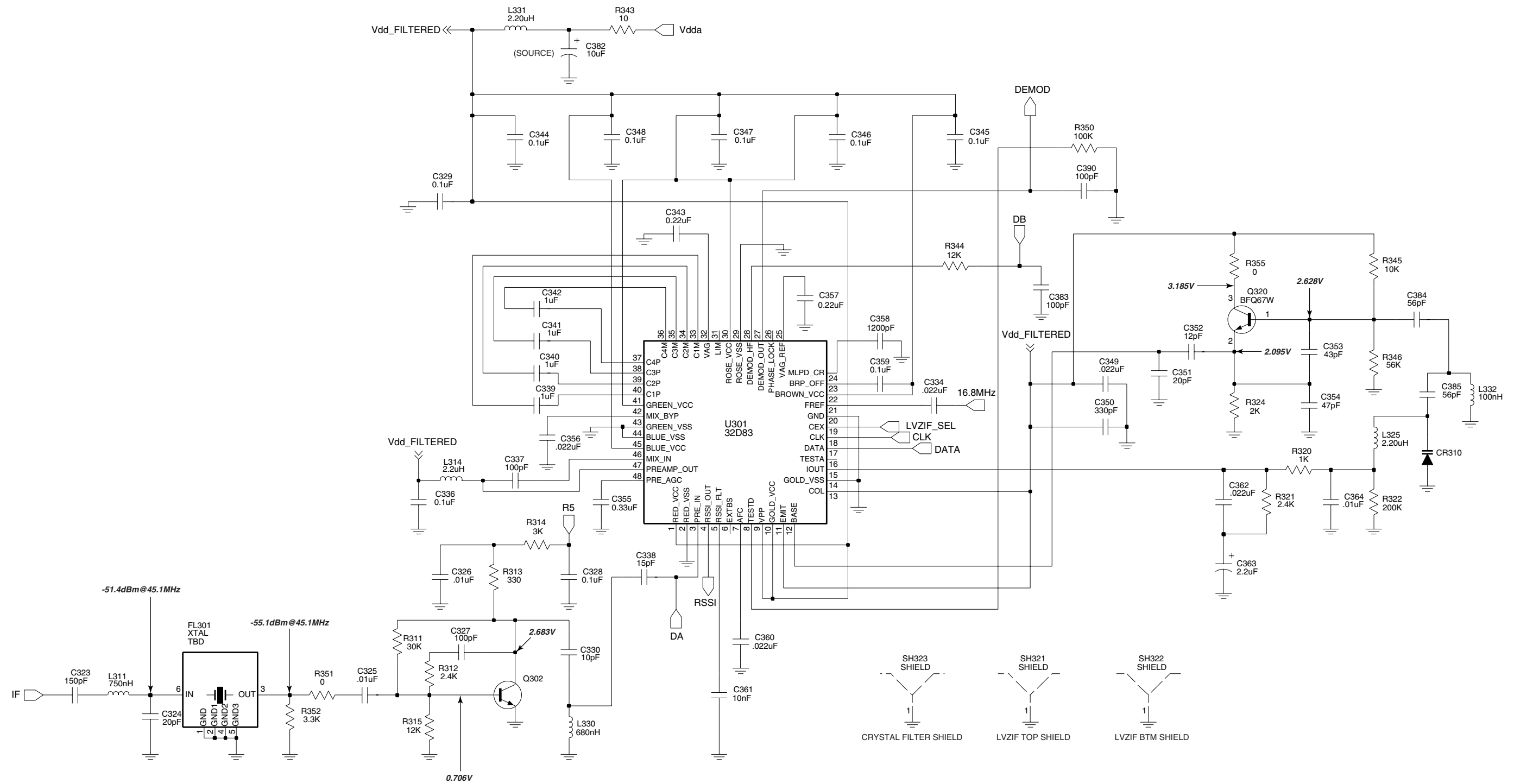

UHF Band 2 Receiver Back End Schematic Diagram

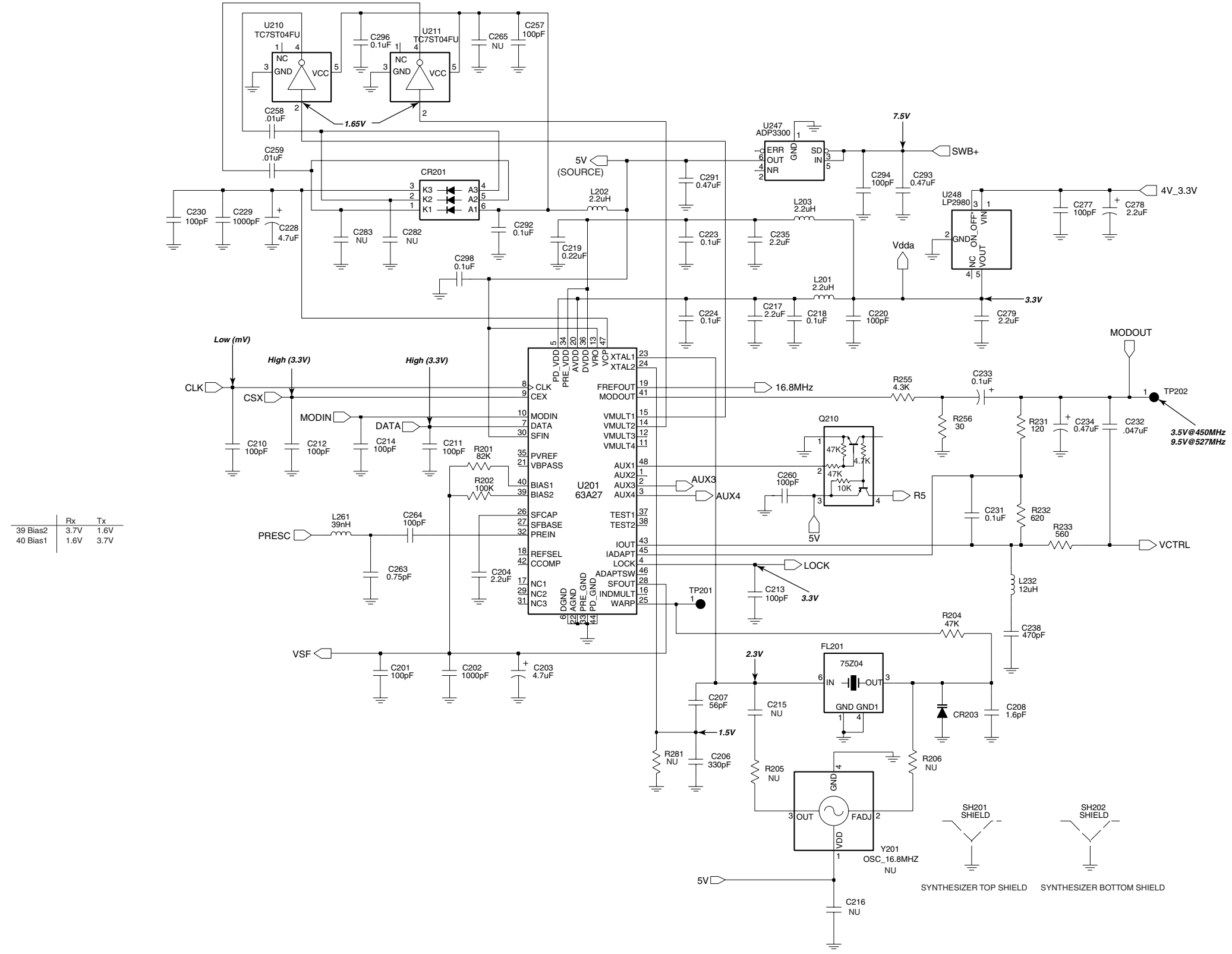

UHF Band 2 Synthesizer Schematic Diagram

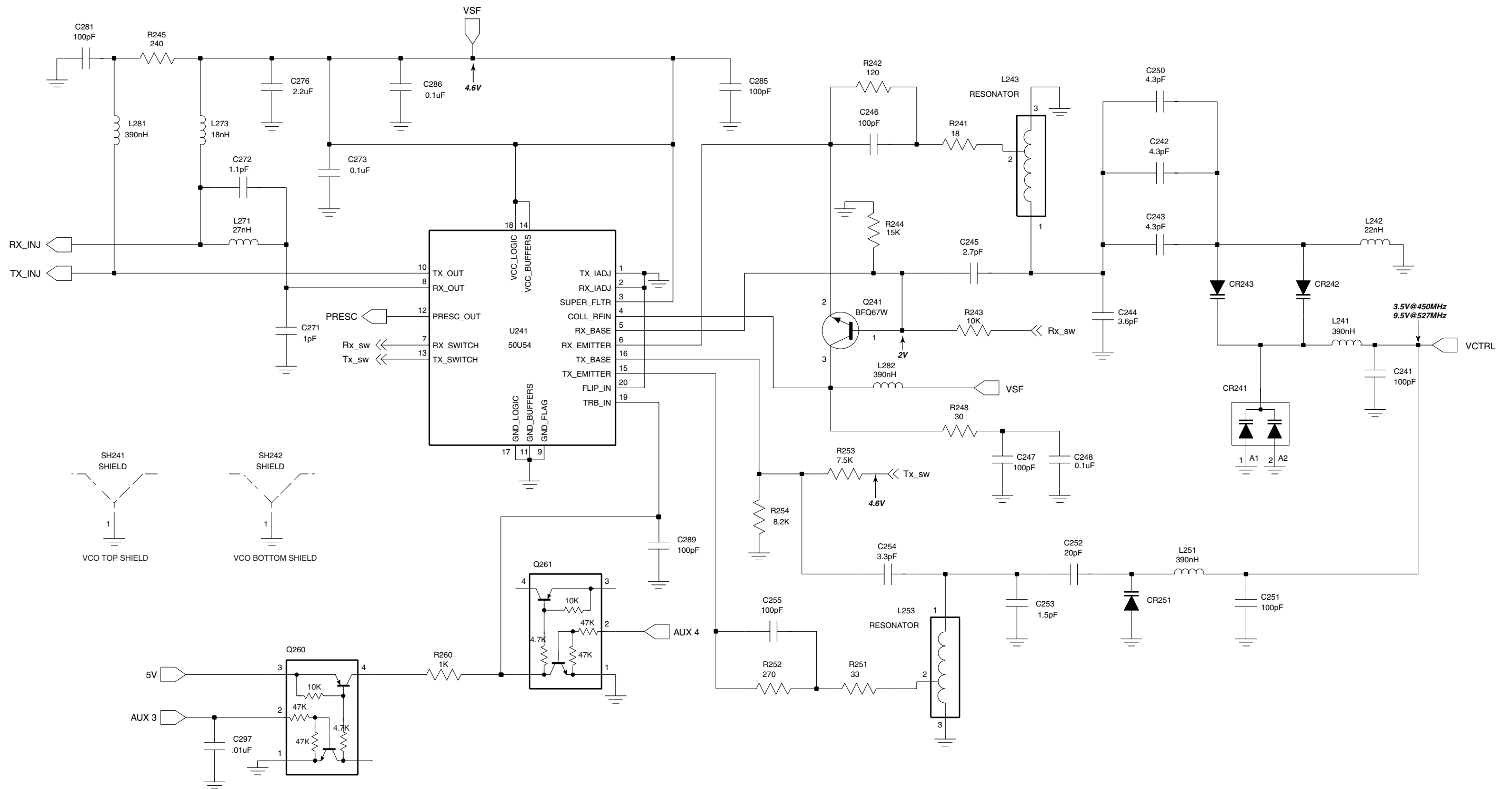

UHF Band 2 Voltage Controlled Oscillator Schematic Diagram

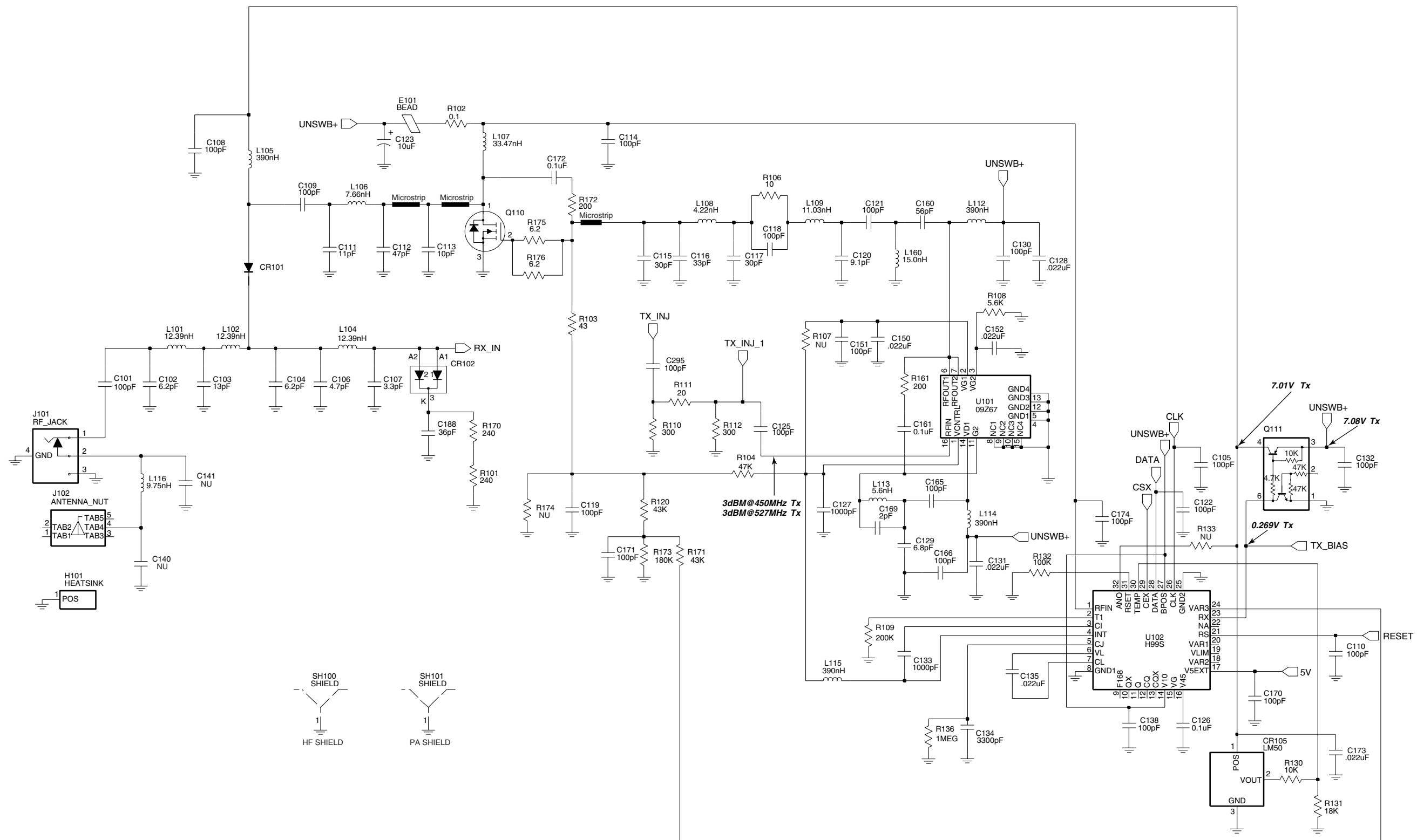

UHF Band 2 Transmitter Schematic Diagram

UHF Band 2 Radio Parts List (RF Board)

Circuit Ref	Motorola Part No.	Description
B501	0986237A02	Battery Contact Connector
B503	3980502Z01	Contact, Backup B+ (not used in GP328 Plus)
B504	3980501Z01	Contact, Backup B- (not used in GP328 Plus)
C101	2113740F51	100
C102	2113740F22	6.2
C103	2113740F28	11
C104	2113740F22	6.2
C105	2113743N50	100 pF, 5%
C106	2113740F19	4.7 pF
C107	2113740F15	3.3
C108	2113743N50	100 pF, 5%
C109	2113740F51	100
C110	2113743N50	100 pF, 5%
C111	2103689A22	11.0, 0.05 pF
C112	2180605Z28	33 pF
C113	2180605Z20	15 pF
C114	2113743N50	100 pF, 5%
C115	2113743N31	16.0 pF, 5%
C116	2113743N27	11.0 pF, 5%
C117	NOT PLACED	
C118	2113743N50	100 pF, 5%
C119	2113743N50	100 pF, 5%
C120	2113743N23	7.5 pF, 0.5 pF
C121	2113743N50	100 pF, 5%
C122	2113743N50	100 pF, 5%
C123	2311049A18	10 uF, 10%
C125	2113743N50	100 pF, 5%
C126	2113743M24	100000 pF, +80% / -20%
C127	2113743L17	1000 pF, 10%
C128	2113743M08	22000 pF, +80% / -20%
C129	2113743N23	7.5 pF, 0.5 pF
C130	2113743N50	100 pF, 5%
C131	2113743M08	22000 pF, +80% / -20%
C132	2113743N50	100 pF, 5%
C133	2113743L17	1000 pF, 10%
C134	2113743L29	3300 pF, 10%
C135	2113743M08	22000 pF, +80% / -20%
C138	2113743N50	100 pF, 5%
C140	0662057A67	5600, 5%
C141	2113740F25	8.2
C150	2113743M08	22000 pF, +80% / -20%
C151	2113743N50	100 pF, 5%
C152	2113743M08	22000 pF, +80% / -20%
C160	2113743N44	56.0 pF, 5%
C161	2113743M24	100000 pF, +80% / -20%

Circuit Ref	Motorola Part No.	Description
C165	2113743N44	56.0 pF, 5%
C166	2113743N50	100 pF, 5%
C169	2113743N09	2.0 pF, 0.25 pF
C170	2113743N50	100 pF, 5%
C171	2113743N50	100 pF, 5%
C172	2113743E20	0.10 uF, 10%
C173	2113743M08	22000 pF, +80% / -20%
C174	2113743N50	100 pF, 5%
C180	NOT PLACED	
C181	NOT PLACED	
C188	2113743N39	36.0 pF, 5%
C201	2113743N50	100 pF, 5%
C202	2113743L17	1000 pF, 10%
C203	2311049A56	4.7
C204	2104993J02	2.2 uF
C206	2113740F63	330, 5%
C207	2113743N40	39.0 pF, 5%
C208	NOT PLACED	
C210	2113743N50	100 pF, 5%
C211	2113743N50	100 pF, 5%
C212	2113743N50	100 pF, 5%
C213	2113743N50	100 pF, 5%
C214	2113743N50	100 pF, 5%
C215	NOT PLACED	
C216	NOT PLACED	
C217	2104993J02	2.2 uF
C218	2113743M24	100000 pF, +80% / -20%
C219	2113743K16	0.220 uF, +80% / -20%
C220	2113743N50	100 pF, 5%
C223	2113743M24	100000 pF, +80% / -20%
C224	2113743M24	100000 pF, +80% / -20%
C228	2311049J11	4.7 uF, 10%
C229	2113743L17	1000 pF, 10%
C230	2113743N50	100 pF, 5%
C231	2113743M24	100000 pF, +80% / -20%
C232	2113743E12	0.047 uF, 10%
C233	2311049A01	0.1
C234	2311049A05	0.47 uF, 10%
C235	2104993J02	2.2 uF
C238	2113741F17	470 pF
C241	2113743N50	100 pF, 5%
C242	2113743N17	4.3 pF, 0.25 pF
C243	2113743N17	4.3 pF, 0.25 pF
C244	2113740F14	3.0 pF
C245	2113743N12	2.7 pF, 0.25 pF
C246	2113743N50	100 pF, 5%
C247	2113743N50	100 pF, 5%
C248	2113743M24	100000 pF, +80% / -20%
C250	2113743N17	4.3 pF, 0.25 pF
C251	2113743N50	100 pF, 5%
C252	2113743N26	10.0 pF, 5%

Circuit Ref	Motorola Part No.	Description
C253	2113740L01	2.0 pF
C254	2113743N26	10.0 pF, 5%
C255	2113743N50	100 pF, 5%
C257	2113743N50	100 pF, 5%
C258	2113743L41	10000 pF, 10%
C259	2113743L41	10000 pF, 10%
C260	2113743N50	100 pF, 5%
C263	2113743N02	0.75 pF, 0.25 pF
C264	2113743N50	100 pF, 5%
C265	NOT PLACED	
C271	2113743N03	1.0 pF, 0.25 pF
C272	2113743N04	1.1 pF, 0.25 pF
C273	2113743M24	100000 pF, +80% / -20%
C276	2104993J02	2.2 uF
C277	2113743N50	100 pF, 5%
C278	2311049A09	2.2 uF, 10%
C279	2104993J02	2.2 uF
C281	2113743N50	100 pF, 5%
C282	NOT PLACED	
C283	NOT PLACED	
C285	2113743N50	100 pF, 5%
C286	2113743M24	100000 pF, +80% / -20%
C289	2113743N50	100 pF, 5%
C291	2311049A69	10.0 uF, 20%
C292	2113743M24	100000 pF, +80% / -20%
C293	2113743A27	0.470 uF, 10%
C294	2113743N50	100 pF, 5%
C295	2113743N50	100 pF, 5%
C296	2113743M24	100000 pF, +80% / -20%
C297	2113743L41	10000 pF, 10%
C298	2113743M24	100000 pF, +80% / -20%
C301	2113743N24	8.2 pF, 0.5 pF
C302	2113743N28	12.0 pF, 5%
C303	2113740L09	4.3 pF, 0.1 pF
C304	2113743N27	11.0 pF, 5%
C305	2113743N24	8.2 pF, 0.5 pF
C306	NOT PLACED	
C307	2113743M24	100000 pF, +80% / -20%
C308	2113743N50	100 pF, 5%
C309	2113743N50	100 pF, 5%
C310	2113743M24	100000 pF, +80% / -20%
C311	NOT PLACED	
C312	2113743N23	7.5 pF, 0.5 pF
C313	2113743N27	11.0 pF, 5%
C314	2113743M24	100000 pF, +80% / -20%
C315	2113743N50	100 pF, 5%
C316	2113740L09	4.3 pF, 0.1 pF
C317	2113743N27	11.0 pF, 5%
C318	2113743N23	7.5 pF, 0.5 pF
C319	2113743N15	3.6 pF, 0.25 pF
C320	2113743N23	7.5 pF, 0.5 pF

Circuit Ref	Motorola Part No.	Description
C321	2113743N50	100 pF, 5%
C322	2113743N48	82.0 pF, 5%
C323	2113743N54	150 pF, 5%
C324	2113743N33	20.0 pF, 5%
C325	2113743L41	10000 pF, 10%
C326	2113743L41	10000 pF, 10%
C327	2113743N50	100 pF, 5%
C328	2113743M24	100000 pF, +80% / -20%
C329	2113743M24	100000 pF, +80% / -20%
C330	2113743N26	10.0 pF, 5%
C331	2113743N50	100 pF, 5%
C333	NOT PLACED	
C334	2113743M08	22000 pF, +80% / -20%
C336	2113743M24	100000 pF, +80% / -20%
C337	2113743N50	100 pF, 5%
C338	2113743N30	15.0 pF, 5%
C339	2180478Z20	1.0 uF
C340	2180478Z20	1.0 uF
C341	2180478Z20	1.0 uF
C342	2180478Z20	1.0 uF
C343	2113743A23	0.220 uF, 10%
C344	2113743M24	100000 pF, +80% / -20%
C345	2113743M24	100000 pF, +80% / -20%
C346	2113743M24	100000 pF, +80% / -20%
C347	2113743M24	100000 pF, +80% / -20%
C348	2113743M24	100000 pF, +80% / -20%
C349	2113743E07	0.022 uF
C350	2113743L05	330 pF, 10%
C351	2113743N33	20.0 pF, 5%
C352	2113743N28	12.0 pF, 5%
C353	2113743N41	43.0 pF, 5%
C354	2113743N42	47.0 pF, 5%
C355	2113743A24	0.330 uF, 10%
C356	2113743M08	22000 pF, +80% / -20%
C357	2113743A23	0.220 uF, 10%
C358	2113741A23	1200 pF, 5%
C359	2109720D14	0.1 uF
C360	2113743E07	0.022 uF
C361	2113741F49	10000
C362	2113743M08	22000 pF, +80% / -20%
C363	2311049A40	2.2 uF, 10%
C364	2113743L41	10000 pF, 10%
C370	2113743N50	100 pF, 5%
C371	NOT PLACED	
C372	NOT PLACED	
C373	NOT PLACED	
C374	2113743N50	100 pF, 5%
C375	2113743N50	100 pF, 5%
C378	NOT PLACED	
C380	2113743L41	10000 pF, 10%
C381	2113743N18	4.7 pF, 0.25 pF

Circuit Ref	Motorola Part No.	Description
C382	2311049A59	10.0 uF, 10%
C383	2113743N50	100 pF, 5%
C384	2113743N44	56.0 pF, 5%
C385	2113743N44	56.0 pF, 5%
C386	2113743N50	100 pF, 5%
C390	2113743N50	100 pF, 5%
C391	NOT PLACED	
C395	2113743N50	100 pF, 5%
C396	NOT PLACED	
C397	2311049A07	1.0 uF, 10%
C502	2311049A05	0.47 uF, 10%
C503	2113743N50	100 pF, 5%
C505	2113743N50	100 pF, 5%
C511	2113743N50	100 pF, 5%
C512	2113743N50	100 pF, 5%
C513	2113743N50	100 pF, 5%
C514	2113743N50	100 pF, 5%
C520	2113743L41	10000 pF, 10%
C521	2113743L41	10000 pF, 10%
C522	2113743L41	10000 pF, 10%
C525	2113743N50	100 pF, 5%
C526	2113743N50	100 pF, 5%
C527	2113743N50	100 pF, 5%
C528	2113743N50	100 pF, 5%
C529	2113743N50	100 pF, 5%
C530	2113743N50	100 pF, 5%
C531	2113743N50	100 pF, 5%
C532	2113743N50	100 pF, 5%
C533	2113743N50	100 pF, 5%
C534	2113743N50	100 pF, 5%
C535	2113743N50	100 pF, 5%
C536	2113743N50	100 pF, 5%
C537	2113743N50	100 pF, 5%
C538	2113743N50	100 pF, 5%
C539	NOT PLACED	
C540	NOT PLACED	
C541	NOT PLACED	
C542	NOT PLACED	
C543	NOT PLACED	
C544	2113743N50	100 pF, 5%
C545	2113743N50	100 pF, 5%
C546	2113743N50	100 pF, 5%
C547	2113743N50	100 pF, 5%
C548	NOT PLACED	
C549	2113743N50	100 pF, 5%
C550	2113743N50	100 pF, 5%
C551	2113743N50	100 pF, 5%
C552	2113743N50	100 pF, 5%
C553	2113743N50	100 pF, 5%
C555	2113743N50	100 pF, 5%
CR101	4880973Z02	PIN Diode

Circuit Ref	Motorola Part No.	Description
CR102	4802245J41	PIN Diode
CR103	4802245J41	PIN Diode
CR105	5185963A15	Temperature Sensor
CR160	NOT PLACED	
CR201	4802233J09	Triple Diode
CR203	4862824C03	Varactor Diode
CR241	4805649Q13	Varactor Diode
CR242	4862824C01	Varactor Diode
CR243	4862824C01	Varactor Diode
CR251	4802245J22	Varactor Diode
CR301	4862824C01	Varactor Diode
CR302	4862824C01	Varactor Diode
CR303	4880154K03	Dual Diode
CR304	4862824C01	Varactor Diode
CR305	4862824C01	Varactor Diode
CR306	4802245J42	Ring Quad Diode
CR308	4802245J41	PIN Diode
CR310	4862824C01	Varactor Diode
CR501	4880107R01	Rectifier
CR503	4805729G49	Red / Yellow Diode
E101	2484657R01	Inductor Bead Chip
F501	6580542Z01	Fuse 3A
FL201	**4805875Z04	Crystal 16.8 MHz
FL301	9186153B01	X'tal Filter
H101	2680499Z01	Heat Spreader
J101	0985613Z01	RF Jack
J102	0280519Z02	Antenna Nut (Ref: 0280519Z04)
J200	0905505Y04	Conn ZIF Horizontal
L101	2460591B28	13.37
L102	2460591B28	13.37
L104	2460591B48	15.22
L105	2462587N22	390 nH, 10%
L106	2460591A19	8.71
L107	2479990G01	33.47 nH
L108	2479990A01	4.22 nH
L112	2462587N45	22 nH, 5%
L113	2413926H09	5.6 nH, 0.3 nH
L114	2462587N45	22 nH, 5%
L115	2462587N22	390 nH, 10%
L116	2479990C02	16.28 nH
L117	2409154M17	22.0 nH
L160	2413926H14	15.0 nH, 5%
L201	2462587Q20	2200 nH, 20%
L202	2462587Q20	2200 nH, 20%
L203	2462587Q20	2200 nH, 20%
L232	2462587P25	12000 nH, 5%
L241	2462587V41	390 nH, 10%
L242	2462587V26	22 nH, 5%
L243	2460593C03	Teflon Resonator
L251	2462587V41	390 nH, 10%

Circuit Ref	Motorola Part No.	Description
L253	2460593C03	Teflon Resonator
L261	2462587V29	39 nH, 5%
L271	2462587V27	27 nH, 5%
L273	2462587V25	18 nH, 5%
L281	2462587V41	390 nH, 10%
L282	2462587V41	390 nH, 10%
L301	2479990B01	11.03 nH
L302	2479990B01	11.03 nH
L303	2462587V26	22 nH, 5%
L304	2462587V37	180 nH, 5%
L305	2462587V23	12 nH, 5%
L306	2479990B01	11.03 nH
L307	2479990B01	11.03 nH
L309	2479990C02	16.28 nH
L310	2462587V36	150 nH, 5%
L311	2462587N65	750 nH, 5%
L314	2462587N72	2200 nH, 5%
L321	NOT PLACED	
L325	2480646Z20	2.20 uH
L330	2462587N64	680 nH, 5%
L331	2480646Z20	2.20 uH
L332	2462587N53	100 nH, 5%
L340	2462587V41	390 nH, 10%
L505	2462587Q42	390 nH, 10%
P100	3905643V01	Ground Contact
PB501	4070354A01	Light Touch Switch
PB502	4070354A01	Light Touch Switch
PB504	4070354A01	Light Touch Switch
PB505	4070354A01	Light Touch Switch
Q110	4813828A09	Transistor 8W 450MHz
Q111	4809939C05	Transistor Dual NPN / PNP
Q210	4809939C05	Transistor Dual NPN / PNP
Q241	4805218N63	RF Transistor BFQ67W
Q260	4809939C05	Transistor Dual NPN / PNP
Q261	4809939C05	Transistor Dual NPN / PNP
Q301	4802245J44	NPN Silicon Bipolar Transistor
Q302	4802245J44	NPN Silicon Bipolar Transistor
Q310	NOT PLACED	
Q315	4880214G02	Transistor MMBT3904
Q316	NOT PLACED	
Q320	4805218N63	RF Transistor BFQ67W
Q502	5180159R01	Dual Transistor NPN
Q505	4880214G02	Transistor MMBT3904
R101	0662057A34	240, 5%
R102	0680539Z01	Power Metal Strip Resistor
R104	0662057N15	47 k, 5%
R106	0662057M26	10, 5%
R107	NOT PLACED	
R108	0662057M92	5600, 5%
R109	0662057N30	200 k, 5%
R110	0662057M61	300, 5%

Circuit Ref	Motorola Part No.	Description
R111	0662057M33	20, 5%
R112	0662057M61	300, 5%
R120	0662057N14	43 k, 5%
R130	0662057M98	10 k, 5%
R131	0662057N05	18 k, 5%
R132	0662057N33	270 k, 5%
R133	NOT PLACED	
R136	NOT PLACED	
R161	0662057M57	200, 5%
R170	0662057A34	240, 5%
R171	0662057N14	43 k, 5%
R172	0662057A32	200, 5%
R173	0662057N29	180 k, 5%
R174	0662057N15	47 k, 5%
R175	0662057B59	3.0, 5%
R176	0662057B59	3.0, 5%
R191	0662057C01	0
R201	0662057N21	82 k, 5%
R202	0662057N23	100 k, 5%
R204	0662057N15	47 k, 5%
R205	NOT PLACED	
R206	NOT PLACED	
R231	0662057M52	120, 5%
R232	0662057M69	620, 5%
R233	0662057M68	560, 5%
R241	0662057M32	18, 5%
R242	0662057M52	120, 5%
R243	0662057M98	10 k, 5%
R244	0662057N03	15 k, 5%
R245	0662057M59	240, 5%
R248	0662057M37	30, 5%
R251	0662057M38	33, 5%
R252	0662057M60	270, 5%
R253	0662057M95	7500, 5%
R254	0662057M96	8200, 5%
R255	0662057M89	4300, 5%
R256	0662057M37	30, 5%
R260	0662057M74	1000, 5%
R281	NOT PLACED	
R300	0662057M82	2200, 5%
R301	0662057N23	100 k, 5%
R302	0662057N23	100 k, 5%
R303	0662057M78	1500, 5%
R304	0662057N01	12 k, 5%
R305	0662057M66	470, 5%
R306	0662057N23	100 k, 5%
R307	0662057N23	100 k, 5%
R308	0662057M60	270, 5%
R309	0662057M32	18, 5%
R310	0662057M60	270, 5%
R311	0662057N10	30 k, 5%

Circuit Ref	Motorola Part No.	Description
R312	0662057M83	2400, 5%
R313	0662057M62	330, 5%
R314	0662057M85	3000, 5%
R315	0662057N01	12 k, 5%
R316	0662057A96	91 k, 5%
R317	0662057M74	1000, 5%
R318	0662057A79	18 k, 5%
R319	0662057A29	150, 5%
R320	0662057M74	1000, 5%
R321	0662057M83	2400, 5%
R322	0662057N30	200 k, 5%
R324	0662057M81	2000, 5%
R325	0662057M94	6800, 5%
R326	NOT PLACED	
R327	0662057N11	33 k, 5%
R328	0662057M12	2.7, 5%
R329	0662057M01	0, 5%
R330	NOT PLACED	
R331	NOT PLACED	
R332	NOT PLACED	
R333	NOT PLACED	
R334	NOT PLACED	
R335	NOT PLACED	
R336	NOT PLACED	
R338	NOT PLACED	
R339	0662057M01	0, 5%
R340	0662057M96	8200, 5%
R342	0662057N23	100 k, 5%
R343	0662057M26	10, 5%
R344	0662057N01	12 k, 5%
R345	0662057M98	10 k, 5%
R346	0662057N17	56 k, 5%
R347	0662057M74	1000, 5%
R348	0662057M87	3600, 5%
R349	0662057C01	0
R350	0662057N23	100 k, 5%
R351	0662057C01	0
R352	0662057M86	3300, 5%
R355	0662057M01	0, 5%
R501	0662057M70	680, 5%
R502	0662057M56	180, 5%
R505	0662057M98	10 k, 5%
R506	0662057N15	47 k, 5%
R507	0662057M01	0, 5%
R509	0662057M01	0, 5% (not used in GP328 Plus)
R510	0662057M01	0, 5%
R511	NOT PLACED	
RT300	0680590Z01	Thermistor 33k
RT301	NOT PLACED	

Circuit Ref	Motorola Part No.	Description
S501	4080710Z01	Channel Switch (Ref: 4080710Z09)
	4080710Z05	Channel Switch (used in PMUE2049_ only) (Ref: 4080710Z12)
S502	1880619Z02	Potentiometer (Volume)
SH100	2680507Z01	Shield, Harmonic Filter
SH101	2680510Z01	Shield, PA
SH201	2680511Z01	Shield, Synthesizer
SH202	2680511Z01	Shield, Synthesizer
SH241	2604120G01	Shield, VCO
SH242	2680514Z01	Shield, VCO Bottom / LVZIF
SH301	2680554Z01	Shield, Receiver Front End Top
SH302	2680555Z01	Shield, Receiver Front End Bottom
SH303	2680509Z01	Shield, Mixer
SH304	2680624Z01	Shield, Mixer Diode
SH321	2680508Z01	Shield, LVZIF 2nd LO
SH322	2680514Z01	Shield, VCO Bottom / LVZIF
SH323	2604082P01	Shield, X'tal Filter
T301	2580541Z02	Balun Transformer
T302	2580541Z02	Balun Transformer
U101	5185130C65	LDMOS Driver
U102	5185765B26	PCIC
U201	5185963A27	LVFRACN
U210	5102463J61	Inverter
U211	5102463J61	Inverter
U241	5105750U54	VCO Buffer
U247	5105739X05	5V Regulator
U248	5102463J58	3.3V Regulator
U301	5109632D83	LVZIF
VR300	NOT PLACED	
VR439	4880140L17	12V Zener Diode
VR440	4802245J73	6.8V Zener Diode
VR441	4802245J73	6.8V Zener Diode
VR443	4802245J73	6.8V Zener Diode
VR444	4802245J73	6.8V Zener Diode
VR501	4813830A18	6.8V Diode
VR506	4802245J73	6.8V Zener Diode
Y201	NOT PLACED	
	8404102G03	RF PCB
	8404102G04	RF PCB
	8404102G05	RF PCB
	8404102G07	RF PCB

* Motorola Depot Servicing only

** Not Serviceable

THIS PAGE INTENTIONALLY LEFT BLANK

9.0 Troubleshooting charts

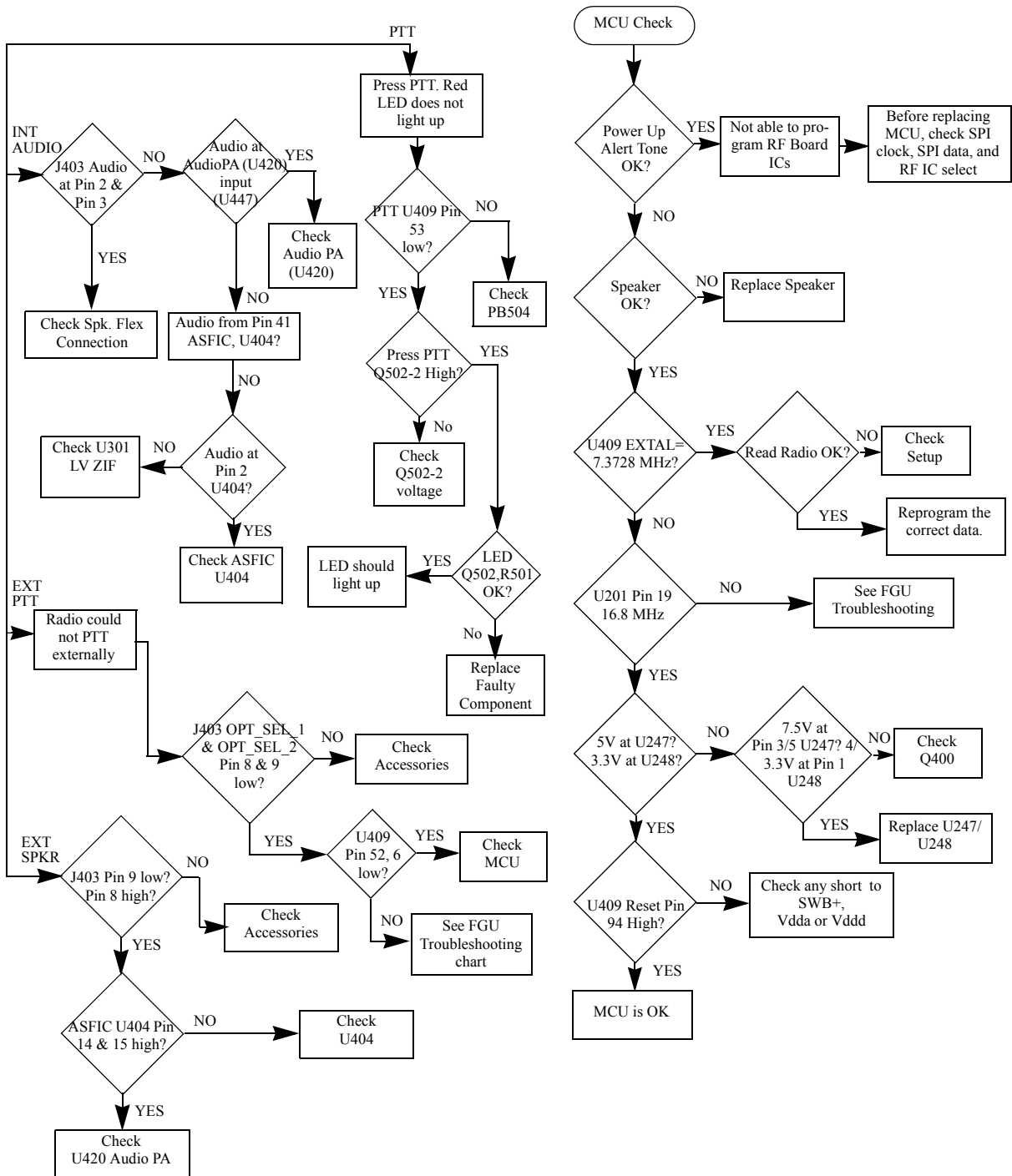

Troubleshooting Flow Chart for Controller

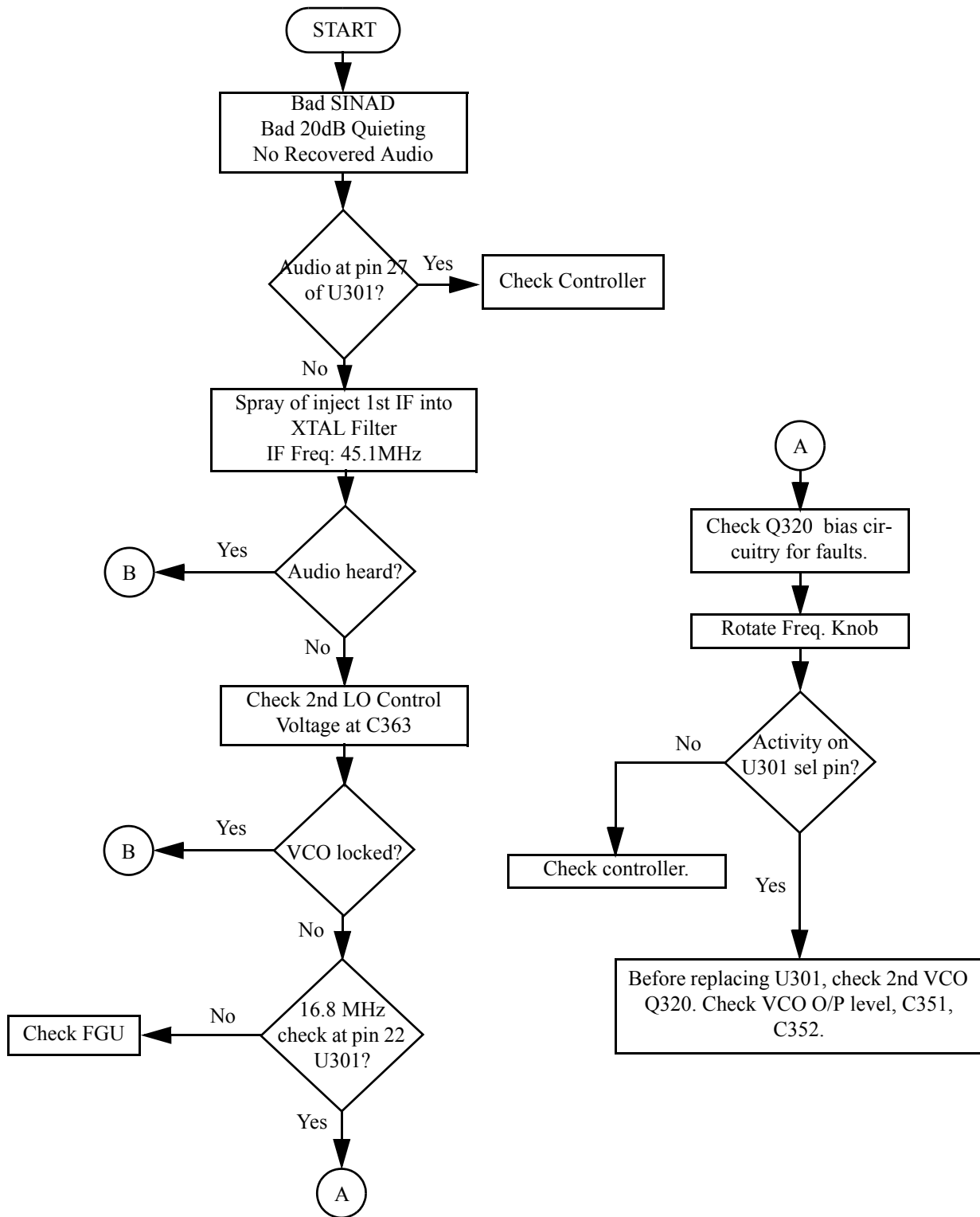

Troubleshooting Flow Chart for Receiver (Sheet 1 of 2)

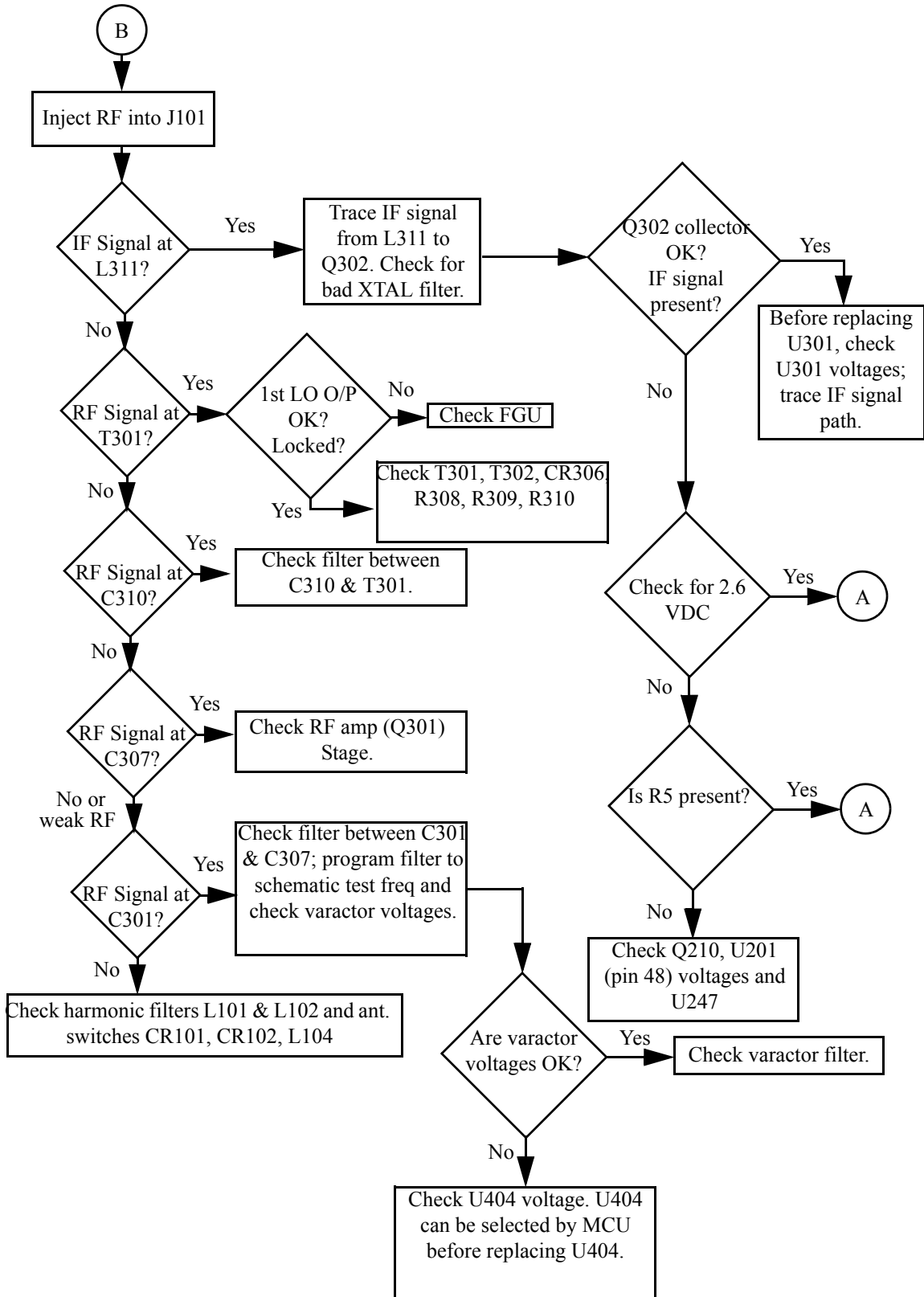

Troubleshooting Flow Chart for Receiver (Sheet 2 of 2)

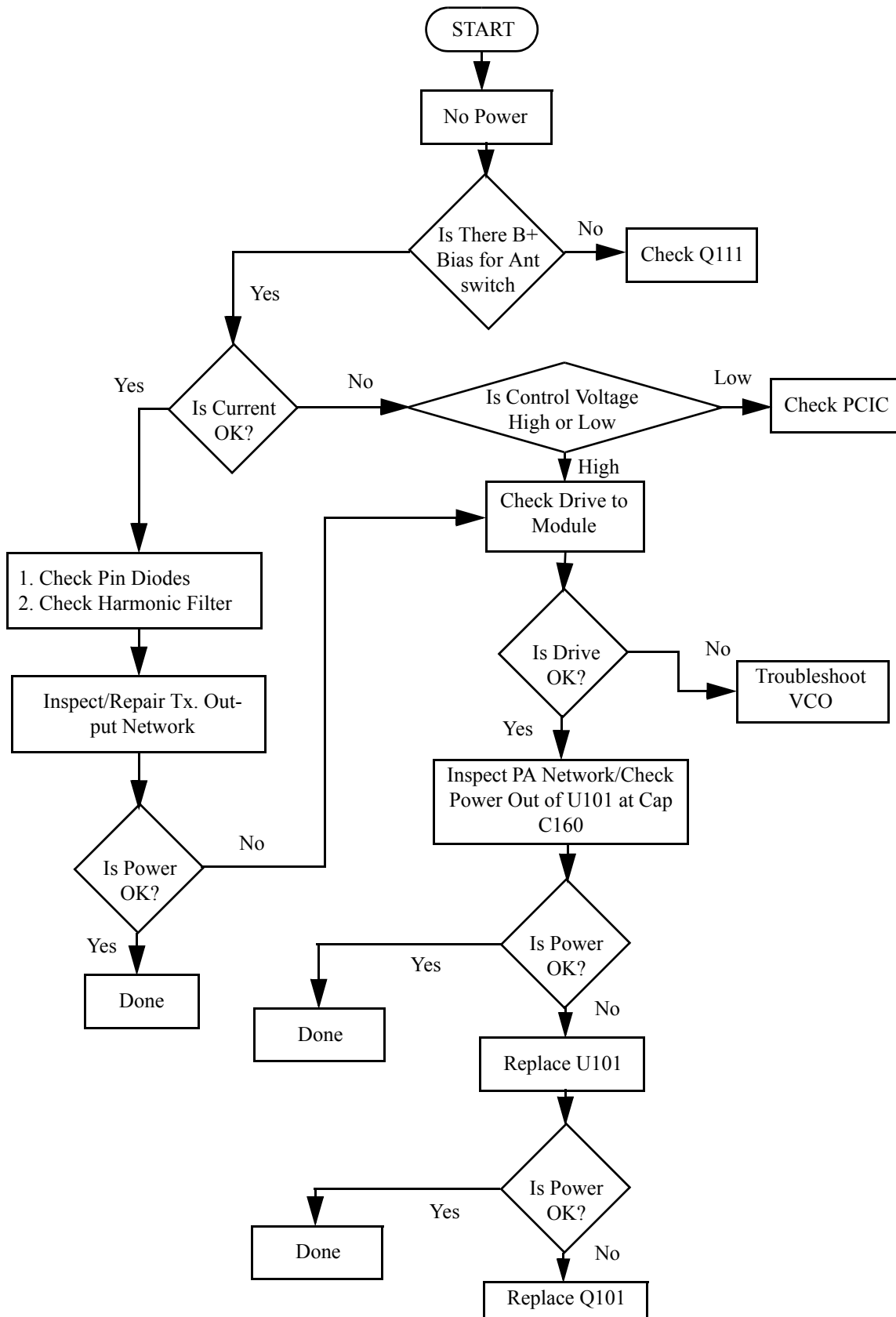

Troubleshooting Flow Chart for Transmitter

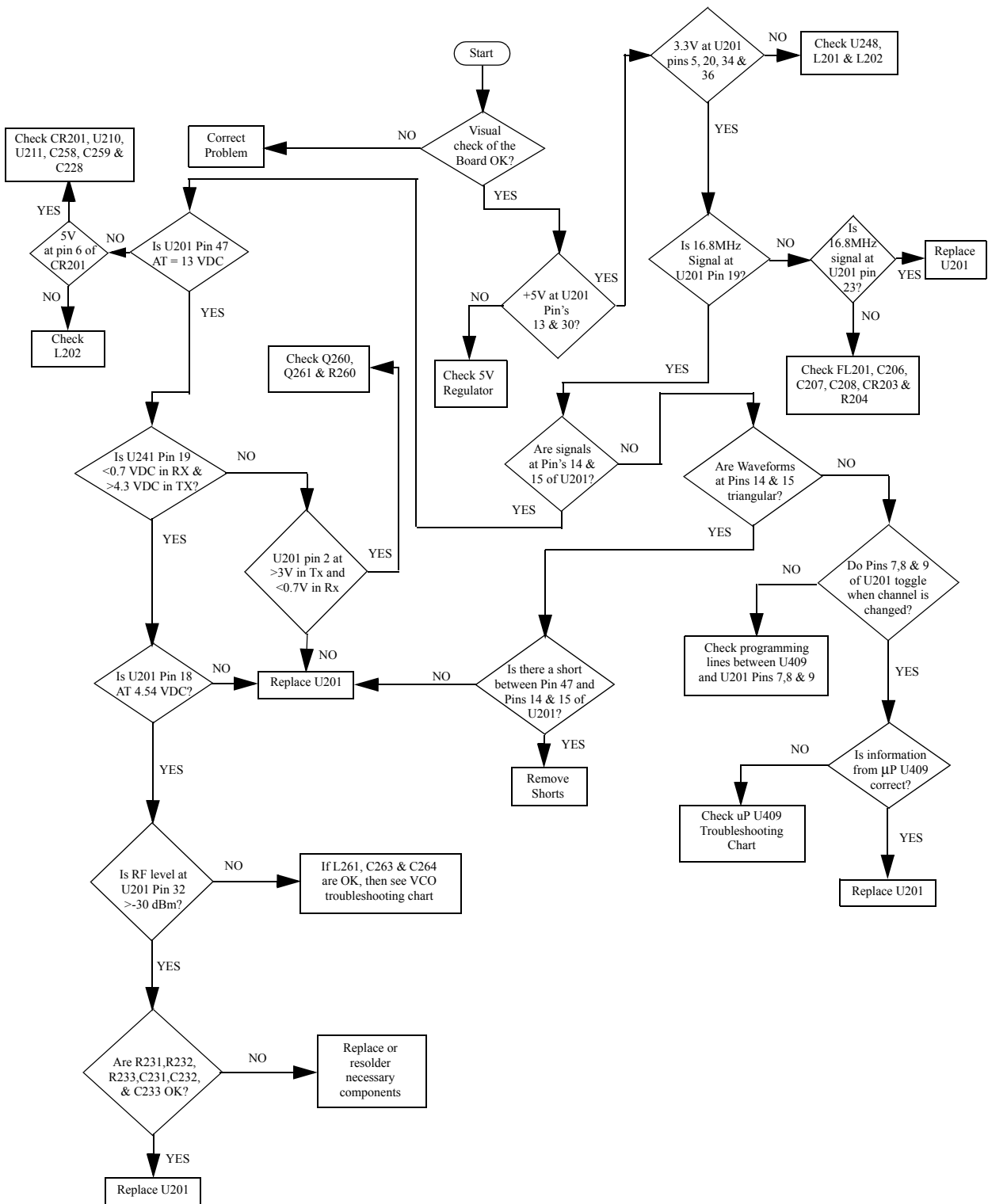

Troubleshooting Flow Chart for Synthesizer

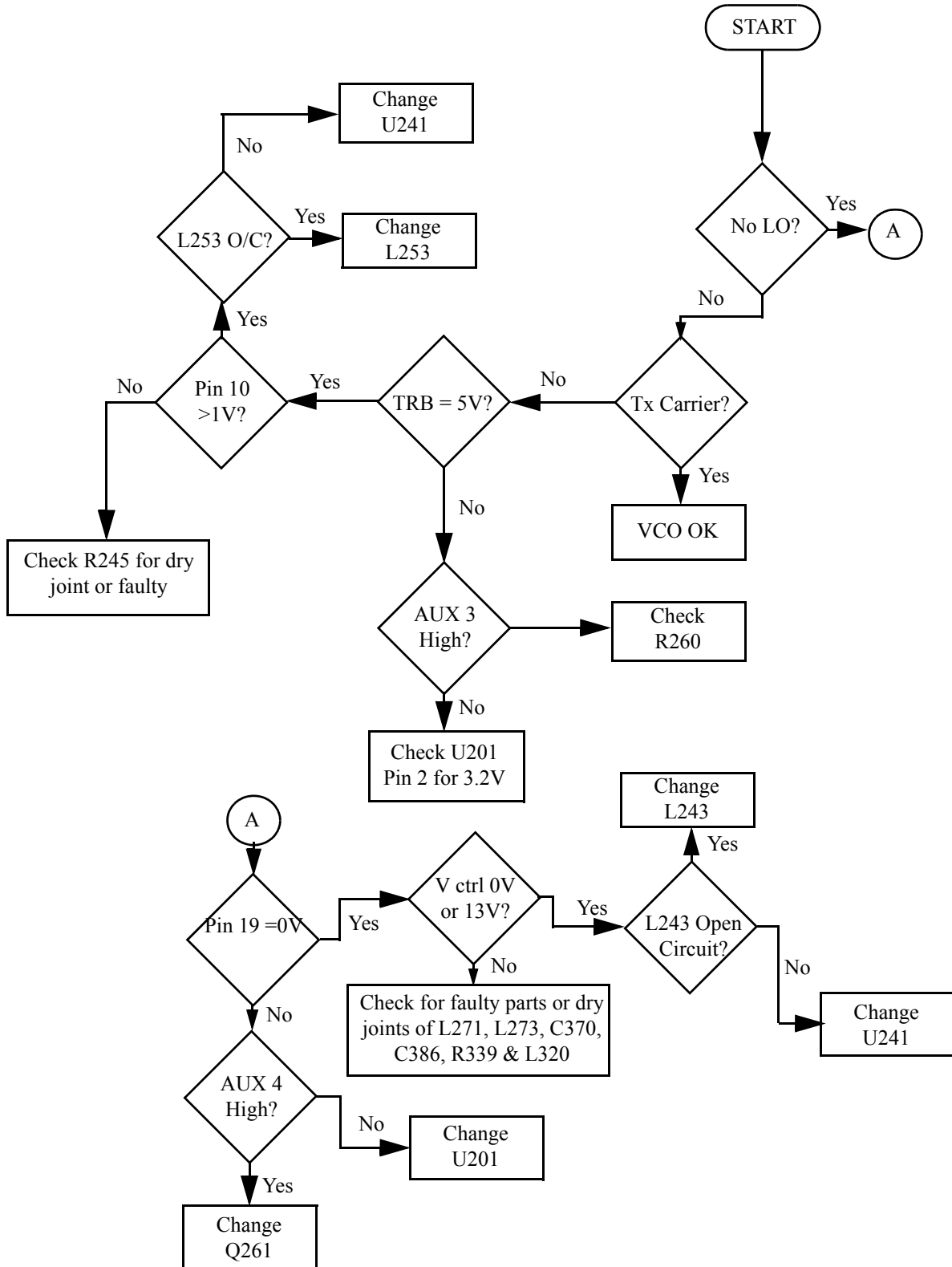

Troubleshooting Flow Chart for VCO

Section 5D

MODEL CHART AND TEST SPECIFICATIONS (330-400 MHZ)

1.0 Model Chart

GP Series, 330-400 MHz			
Model		Description	
	AZH38PDC9AA3	GP328 Plus 330-400 MHz 4W 16 CH	
	AZH38PDH9AA6	GP338 Plus 330-400 MHz 4W 128 CH	
		Item	Description
X		PMUD1675	GP328 Plus Super Tanapa 330-400 MHz 4W
	X	PMUD1676	GP338 Plus Super Tanapa 330-400 MHz 4W 128CH
X		PMUD1679	GP328 Plus Tanapa 330-400 MHz 4W
	X	PMUD1680	GP338 Plus Tanapa 330-400 MHz 4W 128CH
X		JMHD4007	GP328 Plus B/C Kit 330-400 MHz 4W
	X	PMHD4007	GP338 Plus B/C Kit 330-400 MHz 4W 128CH
X		PMHD4002	GP328 Plus Front Housing Kit
	X	PMHD4003	GP338 Plus Front Housing Kit
X	X	PMAD4009	VHF 9 cm antenna (336-368 MHz)
X	X	PMAD4020	VHF 9 cm antenna (370-400 MHz)
X		6804022G48	GP328 Plus User Guide
	X	6804112J64	GP338 Plus User Guide

x = Indicates one of each is required.

2.0 Specifications (for GP328 Plus)

General

	330-400MHz	
Frequency:	330-400 MHz	
Channel Capacity:	GP328 Plus : 16 Channels	
Power Supply:	7.5 Volts ±20%	
Dimensions with Standard High Capacity Lithium Battery:	101.5mm x 55.5mm x 30.5mm	
Dimensions with Ultra High Capacity Lithium Battery:	101.5mm x 55.5mm x 35.5mm	
Weight with Standard High Capacity Lithium Battery:	250 g	
Weight with Ultra High Capacity Lithium Battery:	270 g	
Average Battery Life @ (5-5-90 Duty Cycle)	Low Power	High Power
Standard High Capacity Lithium Battery:	>10 hrs	>7 hrs
Ultra High Capacity Lithium Battery:	>14 hrs	>10 hrs
Sealing:	Meets MIL-STD-810-C,D & E and IPX4	
Shock:	Meets MIL-STD-810-C,D & E and TIA/EIA 603	
Vibration:	Meets MIL-STD-810-C,D & E and TIA/EIA 603	
Dust:	Meets MIL-STD-810-C,D & E and IP5X	
Humidity:	Meets MIL-STD-810-C,D & E and TIA/EIA 603	

Transmitter

	330-400MHz	
RF Output Li Ion @ 7.5V:	Low 1W	High 4W
Frequency	330-400 MHz	
Channel Spacing	12.5/20/25 kHz	
Freq. Stability (-30°C to +60°C)	0.00025%	
Spurs/Harmonics:	-36 dBm < 1 GHz -30 dBm > 1 GHz	
Audio Response: (from 6 dB/oct. Pre-Emphasis, 300 to 3000Hz)	+1, -3 dB	
Audio Distortion: @ 1000 Hz, 60% Rated Max. Dev.	<5%	
FM Noise:	-40 dB	

Receiver

	12.5kHz	20/25kHz
Frequency:	330-400MHz	330-400MHz
Sensitivity 12dB EIA SINAD:	0.35 µV	0.35 µV
Adjacent Channel Selectivity ETS	-60 dB	-70 dB
Intermodulation ETS	-65 dB	-65 dB
Freq. Stability (-30°C to +60°C):	0.00025%	0.00025%
Spur Rejection:	-70 dB	-70 dB
Image Rejection:	-70 dB	-70 dB
Audio Output @ <5% Distortion	500 mW	500 mW

All specifications are subject to change without notice.

3.0 Specifications (for GP338 Plus)

General

	330-400MHz	
Frequency:	330-400 MHz	
Channel Capacity:	GP338 Plus : 128 Channels	
Power Supply:	7.5 Volts ±20%	
Dimensions with Standard High Capacity Lithium Battery:	101.5mm x 55.5mm x 33.0mm	
	with Ultra High Capacity Lithium Battery: 101.5mm x 55.5mm x 38.0mm	
Weight: with Standard High Capacity Lithium Battery:	250 g	
	with Ultra High Capacity Lithium Battery: 270 g	
Average Battery Life @ (5-5-90 Duty Cycle) Standard High Capacity Lithium Battery: Ultra High Capacity Lithium Battery:	Low Power	High Power
	>10 hrs	>7 hrs
	>14 hrs	>10 hrs
Sealing:	Meets MIL-STD-810-C,D & E and IPX4	
Shock:	Meets MIL-STD-810-C,D & E and TIA/EIA 603	
Vibration:	Meets MIL-STD-810-C,D & E and TIA/EIA 603	
Dust:	Meets MIL-STD-810-C,D & E and IP5X	
Humidity:	Meets MIL-STD-810-C,D & E and TIA/EIA 603	

Transmitter

	330-400MHz	
RF Output Li Ion @ 7.5V:	Low 1W	High 4W
Frequency	330-400 MHz	
Channel Spacing	12.5/20/25 kHz	
Freq. Stability (-30°C to +60°C)	0.00025%	
Spurs/Harmonics:	-36 dBm < 1 GHz -30 dBm > 1 GHz	
Audio Response: (from 6 dB/oct. Pre-Emphasis, 300 to 3000Hz)	+1, -3 dB	
Audio Distortion: @ 1000 Hz, 60% Rated Max. Dev.	<5%	
FM Noise:	-40 dB	

Receiver

	12.5kHz	20/ 25kHz
Frequency:	330-400MHz	330-400MHz
Sensitivity 12dB EIA SINAD:	0.35 µV	0.35 µV
Adjacent Channel Selectivity ETS	-60 dB	-70 dB
Intermodulation ETS	-65 dB	-65 dB
Freq. Stability (-30°C to +60°C):	0.00025%	0.00025%
Spur Rejection:	-70 dB	-70 dB
Image Rejection:	-70 dB	-70 dB
Audio Output @ <5% Distortion	500 mW	500 mW

All specifications are subject to change without notice.

4.0 Transmitter

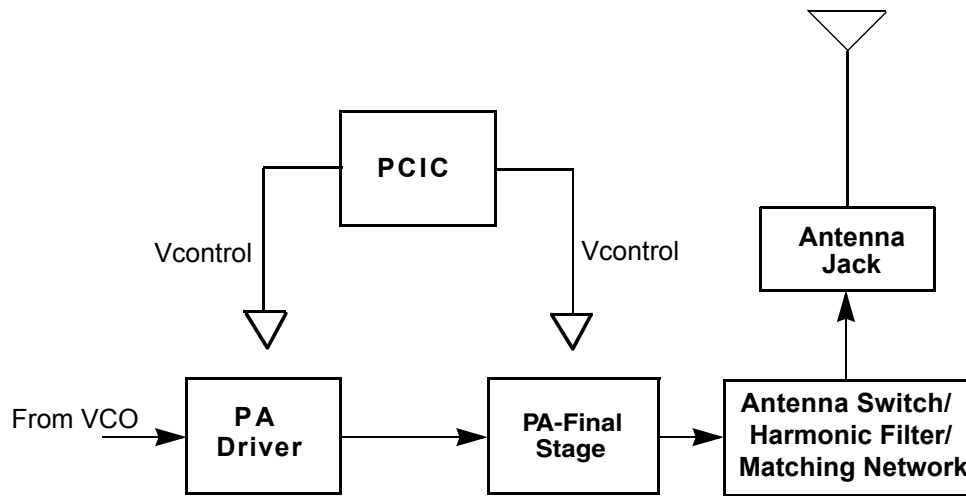

Figure 5-1: Transmitter Block Diagram

4.1 General

(Refer to Figure 5-1)

The transmitter contains five basic circuits:

1. Power Amplifier
2. Antenna Switch
3. Harmonic Filter
4. Antenna Matching Network
5. Power Control Integrated Circuit (PCIC).

4.1.1 Power Amplifier

The power amplifier consists of two devices:

1. 9Z67 LDMOS driver IC (U101) and
2. PRF1507 LDMOS PA (Q110).

The 9Z67 LDMOS driver IC contains a 2 stage amplification with a supply voltage of 7.3V.

This RF power amplifier is capable of supplying an output power of 0.3W (pin 6 and 7) with an input signal of 2mW (3dBm) (pin16). The current drain would typically be 160mA while operating in the frequency range of 330-400MHz.

The PRF1507 LDMOS PA is capable of supplying an output power of 7W with an input signal of 0.3W. The current drain would typically be 1300mA while operating in the frequency range of 330-400MHz. The power output can be varied by changing the biasing voltage.

4.1.2 Antenna Switch

The antenna switch circuit consists of two PIN diodes (CR101 and CR102), a pi network (C107, L104 and C106), and two current limiting resistors (R101, R170). In the transmit mode, B+ at PCIC (U102) pin 23 will go low and turn on Q111 where a B+ bias is applied to the antenna switch circuit to bias the diodes "on". The shunt diode (CR102) shorts out the receiver port, and the pi network, which operates as a quarter wave transmission line, transforms the low impedance of the shunt diode to a high impedance at the input of the harmonic filter. In the receive mode, the diodes are both off, and hence, there exists a low attenuation path between the antenna and receiver ports.

4.1.3 Harmonic Filter

The harmonic filter consists of C104, L102, C103, L101 and C102. The design of the harmonic filter for VHF is that of a modified Zolotarev design. It has been optimized for efficiency of the power module. This type of filter has the advantage that it can give a greater attenuation in the stop-band for a given ripple level. The harmonic filter insertion loss is typically less than 1.2dB.

4.1.4 Antenna Matching Network

A matching network which is made up of L116 is used to match the antenna's impedance to the harmonic filter. This will optimize the performance of the transmitter and receiver into an antenna.

4.1.5 Power Control Integrated Circuit (PCIC)

The transmitter uses the Power Control IC (PCIC), U102 to regulate the power output of the radio. The current to the final stage of the power module is supplied through R101, which provides a voltage proportional to the current drain. This voltage is then fed back to the Automatic Level Control (ALC) within the PCIC to regulate the output power of the transmitter.

The PCIC has internal digital to analog converters (DACs) which provide the reference voltage of the control loop. The reference voltage level is programmable through the SPI line of the PCIC.

There are resistors and integrators within the PCIC, and external capacitors (C133, C134 and C135) in controlling the transmitter rising and falling time. These are necessary in reducing the power splatter into adjacent channels.

CR105 and its associated components are part of the temperature cut back circuitry. It senses the printed circuit board temperature around the transmitter circuits and output a DC voltage to the PCIC. If the DC voltage produced exceeds the set threshold in the PCIC, the transmitter output power will be reduced so as to reduce the transmitter temperature.

5.0 Receiver

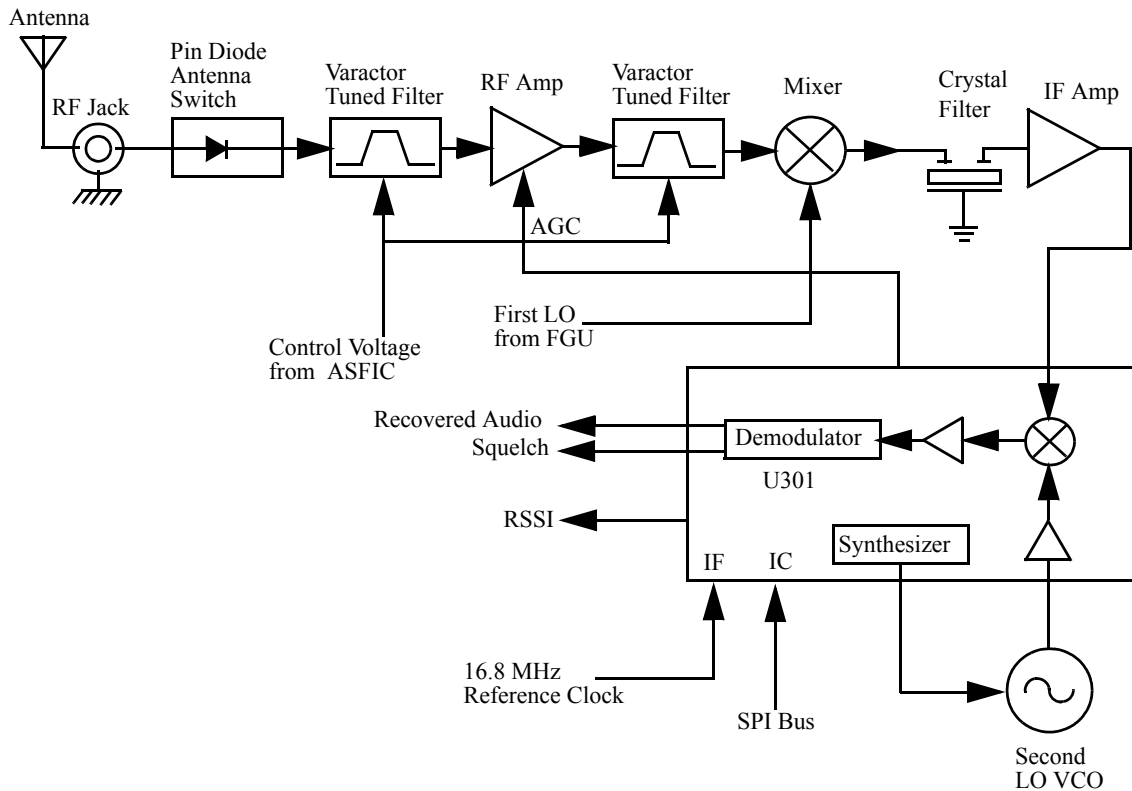

Figure 5-2: Receiver Block Diagram

5.1 Receiver Front-End

(Refer to 330-400MHz Receiver Front End Schematic Diagram on page 5D-22 and 330-400MHz Transmitter Schematic Diagram on page 5D-26)

The RF signal is received by the antenna and applied to a low-pass filter. For VHF, the filter consists of L101, L102, C102, C103, C104. The filtered RF signal is passed through the antenna switch. The antenna switch circuit consists of two PIN diodes (CR101 and CR102) and a pi network (C106, L104 and C107). The signal is then applied to a varactor tuned bandpass filter. The VHF bandpass filter comprises of L301, L302, C302, C303, C304, CR301 and CR302. The bandpass filter is tuned by applying a control voltage to the varactor diodes (CR301 and CR302) in the filter.

The bandpass filter is electronically tuned by the DACRx from U404 which is controlled by the microprocessor. Depending on the carrier frequency, the DACRx will supply the tuned voltage to the varactor diodes in the filter. Wideband operation of the filter is achieved by shifting the bandpass filter across the band.

The output of the bandpass filter is coupled to the RF amplifier transistor Q301 via C307. After being amplified by the RF amplifier, the RF signal is further filtered by a second varactor tuned bandpass filter, consisting of L306, L307, C313, C317, CR304 and CR305.

Both the pre and post-RF amplifier varactor tuned filters have similar responses. The 3 dB bandwidth of the filter is about 50 MHz. This enables the filters to be electronically controlled by using a single control voltage which is DACRx.

The output of the post-RF amplifier filter which is connected to the passive double balanced mixer consists of T301, T302 and CR306. Matching of the filter to the mixer is provided by C381. After mixing with the first LO signal from the voltage controlled oscillator (VCO) using low side injection, the RF signal is down-converted to the 45.1 MHz IF signal.

The IF signal coming out of the mixer is transferred to the crystal filter (FL301) through a resistor pad and a diplexer (C322 and L310). Matching to the input of the crystal filter is provided by C324 and L311. The crystal filter provides the necessary selectivity and intermodulation protection.

5.2 Receiver Back-End

(Refer to *330-400MHz Receiver Back End Schematic Diagram* on page 5D-23)

The output of crystal filter FL301 is matched to the input of IF amplifier transistor Q302 by components R352 and C325. Voltage supply to the IF amplifier is taken from the receive 5 volts (R5). The IF amplifier provides a gain of about 7dB. The amplified IF signal is then coupled into U301(pin 3) via C330, C338 and L330 which provides the matching for the IF amplifier and U301.

The IF signal applied to pin 3 of U301 is amplified, down-converted, filtered, and demodulated, to produce the recovered audio at pin 27 of U301. This IF IC is electronically programmable, and the amount of filtering (which is dependent on the radio channel spacing) is controlled by the microprocessor. Additional filtering, once externally provided by the conventional ceramic filters, is replaced by internal filters in the IF module (U301).

The IF IC uses a type of direct conversion process, whereby the externally generated second LO frequency is divided by two in U301 so that it is very close to the first IF frequency. The IF IC (U301) synthesizes the second LO and phase-locks the VCO to track the first IF frequency. The second LO is designed to oscillate at twice the first IF frequency because of the divide-by-two function in the IF IC.

In the absence of an IF signal, the VCO will “search” for a frequency, or its frequency will vary close to twice the IF frequency. When an IF signal is received, the VCO will lock onto the IF signal. The second LO/VCO is a Colpitts oscillator built around transistor Q320. The VCO has a varactor diode, CR310, to adjust the VCO frequency. The control signal for the varactor is derived from a loop filter consisting of C362, C363, C364, R320 and R321.

The IF IC (U301) also performs several other functions. It provides a received signal-strength indicator (RSSI) and a squelch output. The RSSI is a dc voltage monitored by the microprocessor, and used as a peak indicator during the bench tuning of the receiver front-end varactor filter. The RSSI voltage is also used to control the automatic gain control (AGC) circuit at the front-end.

The demodulated signal on pin 27 of U301 is also used for squelch control. The signal is routed to U404 (ASFIC) where squelch signal shaping and detection takes place. The demodulated audio signal is also routed to U404 for processing before going to the audio amplifier for amplification.

5.3 Automatic Gain Control Circuit

(Refer to *330-400MHz Receiver Front End Schematic Diagram* on page 5D-22)

The front end automatic gain control circuit is to provide automatic gain reduction of the front end RF amplifier via feedback. This action is necessary to prevent overloading of back end circuits. This is achieved by drawing some of the output power from the RF amplifier's output. At high radio frequencies, capacitor C331 provides the low impedance path to ground for this purpose. CR308 is a PIN diode used for switching the path on or off. A certain amount of forward biasing current is needed to turn the PIN diode on. Transistor Q315 provides this current where upon saturation, current will flow via R347, PIN diode, collector and emitter of Q315 and R319 before going to ground. Q315 is an NPN transistor used for switching here. Maximum current flowing through the PIN is mainly limited by the resistor R319.

Radio signal strength indicator, RSSI, a voltage signal, is used to drive Q315 to saturation hence turning it on. RSSI is produced by U301 and is proportional to the gain of the RF amplifier and the input RF signal power to the radio.

Resistor network at the input to the base of Q315 is scaled to turn on Q315, hence activating the AGC, at certain RSSI levels. In order to turn on Q315, the voltage across the transistor's base to ground must be greater or equal to the voltage across R319, plus the base-emitter voltage (V_{be}) present at Q315. The resistor network with thermistor RT300 is capable of providing temperature compensation to the AGC circuit, as RSSI generated by U301 is lower at cold temperatures compared to normal operation at room temperature. Resistor R300 and capacitor C397 form an R-C network used to dampen any transient instability while the AGC is turning on.

6.0 Frequency Generation Circuitry

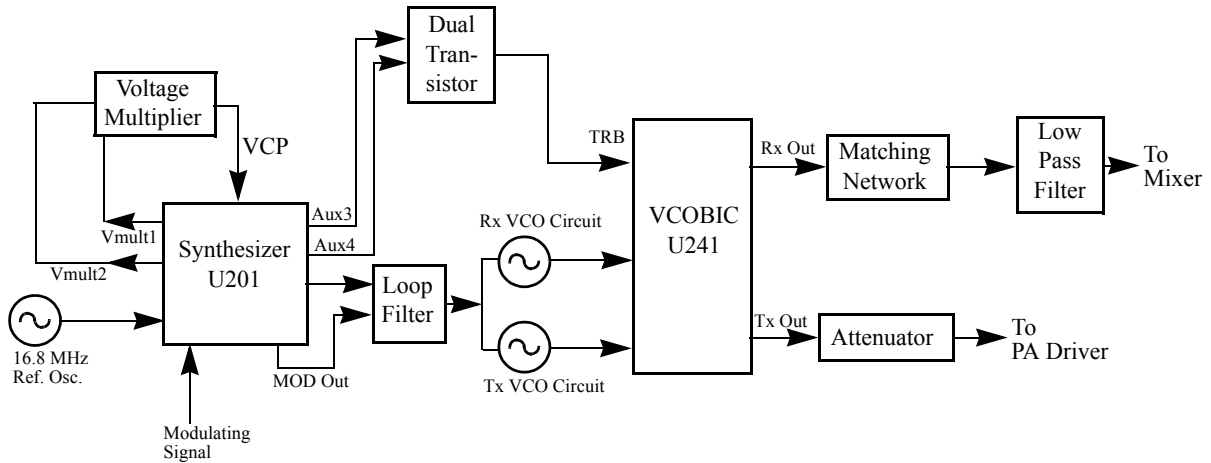

Figure 5-3: Frequency Generation Unit Block Diagram

The Frequency Generation Circuitry is composed of two main ICs, the Fractional-N synthesizer (U201), and the VCO/Buffer IC (U241). Designed in conjunction to maximize compatibility, the two ICs provide many of the functions that normally would require additional circuitry. The synthesizer block diagram illustrates the interconnect and support circuitry used in the region. Refer to the relevant schematics for the reference designators.

The synthesizer is powered by regulated 5V and 3.3V which come from U247 and U248 respectively. The synthesizer in turn generates a superfiltered 4.5V which powers U241.

In addition to the VCO, the synthesizer must interface with the logic and ASFIC circuitry.

Programming for the synthesizer is accomplished through the data, clock and chip select lines from the microprocessor. A 3.3V dc signal from synthesizer lock detect line indicates to the microprocessor that the synthesizer is locked.

Transmit modulation from the ASFIC is supplied to pin10 of U201. Internally the audio is digitized by the Fractional-N and applied to the loop divider to provide the low-port modulation. The audio runs through an internal attenuator for modulation balancing purposes before going out to the VCO.

6.1 Synthesizer

(Refer to 330-400MHz Synthesizer Schematic Diagram on page 5D-24)

The Fractional-N Synthesizer uses a 16.8MHz crystal (FL201) to provide a reference for the system. The LVFractN IC (U201) further divides this to 2.1MHz, 2.225MHz, and 2.4MHz as reference frequencies. Together with C206, C207, C208, R204 and CR203, they build up the reference oscillator which is capable of 2.5ppm stability over temperatures of -30 to 85°C. It also provides 16.8MHz at pin 19 of U201 to be used by ASFIC and LVZIF.

The loop filter which consist of C231, C232, C233, R231, R232 and R233 provides the necessary dc steering voltage for the VCO and determines the amount of noise and spur passing through .

In achieving fast locking for the synthesizer, an internal adapt charge pump provides higher current at pin 45 of U201 to put synthesizer within the lock range. The required frequency is then locked by normal mode charge pump at pin 43 .

Both the normal and adapt charge pumps get their supply from the capacitive voltage multiplier which is made up of C258, C259, C228, triple diode CR201 and level shifters U210 and U211. Two 3.3V square waves (180 deg out of phase) are first shifted to 5V, then along with regulated 5V , put through arrays of diodes and capacitors to build up 13.3V at pin 47 of U201.

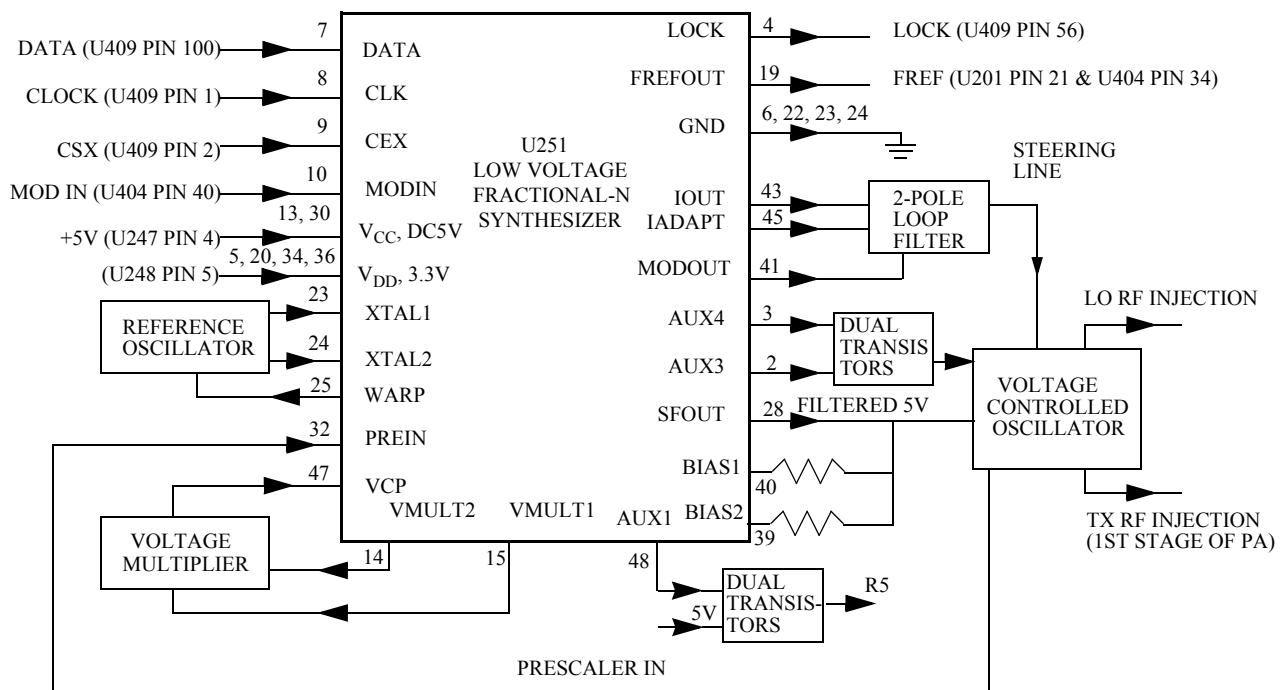

Figure 5-4: Synthesizer Block Diagram

6.2 VCO - Voltage Controlled Oscillator

(Refer to 330-400MHz Voltage Controlled Oscillator Schematic Diagram on page 5D-25)

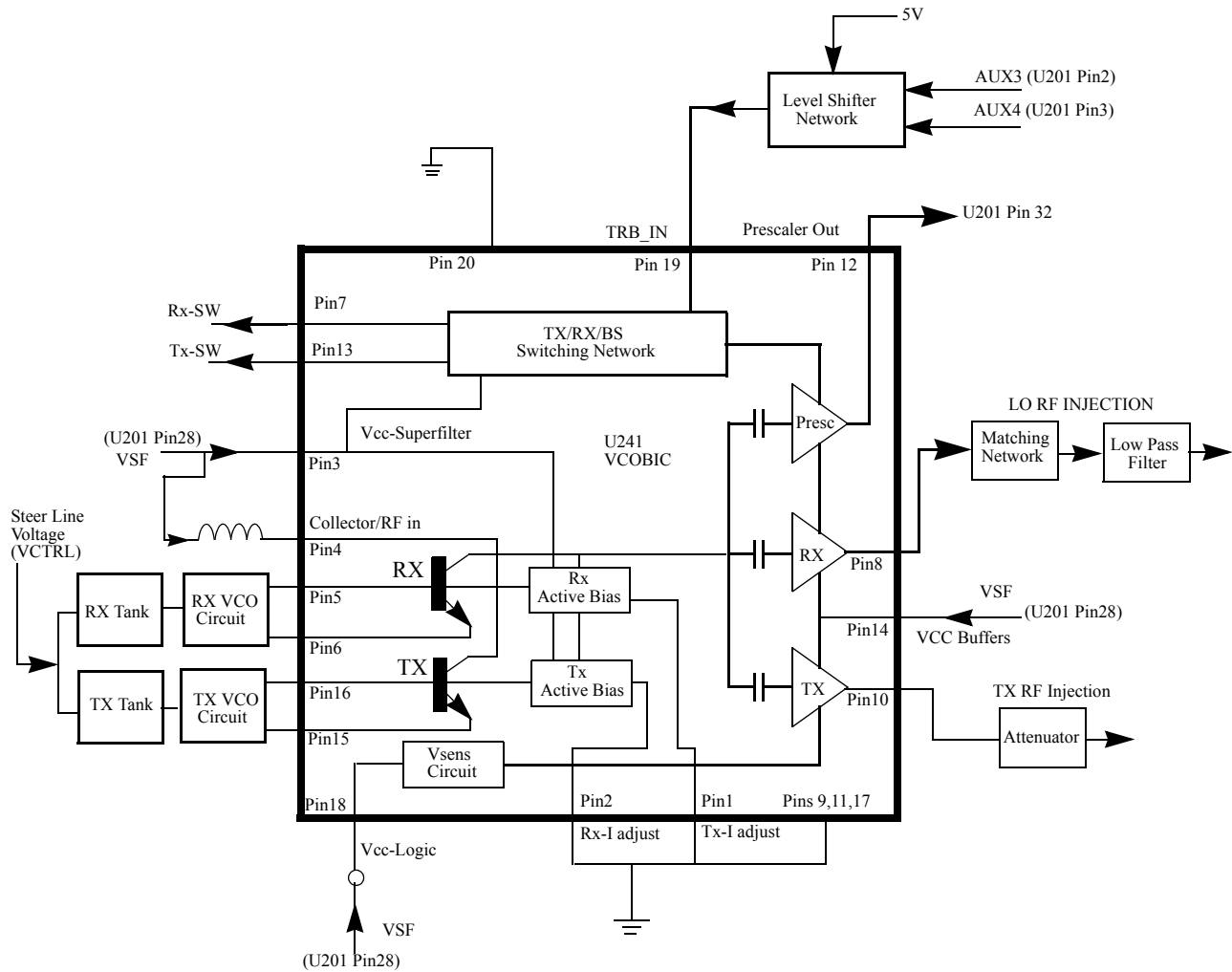

Figure 5-5: VCO Block Diagram

The VCOBIC (U241) in conjunction with the Fractional-N synthesizer (U201) generates RF in both the receive and the transmit modes of operation. The TRB line (U241 pin 19) determines which oscillator and buffer will be enabled. A sample of the RF signal from the enabled oscillator is routed from U241 pin 12, through a low pass filter, to the prescaler input (U201 pin 32). After frequency comparison in the synthesizer, a resultant CONTROL VOLTAGE is received at the VCO. This voltage is a DC voltage between 3.5V and 9.5V when the PLL is locked on frequency.

The VCOBIC(U241) is operated at 4.54 V (VSF) and Fractional-N synthesizer (U201) at 3.3V. This difference in operating voltage requires a level shifter consisting of Q260 and Q261 on the TRB line. The operation logic is shown in Table 5-1.

Table 5-1: Level Shifter Logic

Desired Mode	AUX 4	AUX 3	TRB
Tx	Low	High (@3.2V)	High (@4.8V)
Rx	High	Low	Low
Battery Saver	Low	Low	Hi-Z/Float (@2.5V)

In the receive mode, U241 pin 19 is low or grounded. This activates the receive VCO by enabling the receive oscillator and the receive buffer of U241. The RF signal at U241 pin 8 is run through a matching network. The resulting RF signal is the LO RF INJECTION and it is applied to the mixer at T302 (refer to *330-400MHz Receiver Front End Schematic Diagram* on page 5D-22).

During the transmit condition, when PTT is depressed, five volts is applied to U241 pin 19. This activates the transmit VCO by enabling the transmit oscillator and the transmit buffer of U241. The RF signal at U241 pin 10 is injected into the input of the PA module (U101 pin16). This RF signal is the TX RF INJECTION. Also in transmit mode, the audio signal to be frequency modulated onto the carrier is received through the U201 pin 41.

When a high impedance is applied to U241 pin19, the VCO is operating in BATTERY SAVER mode. In this case, both the receive and transmit oscillators as well as the receive transmit and prescaler buffer are turned off.

7.0 Notes For All Schematics and Circuit Boards

* Component is frequency sensitive. Refer to the Electrical Parts List for value and usage.

1. Unless otherwise stated, resistances are in Ohms ($k = 1000$), and capacitances are in picofarads (pF) or microfarads (μF).
2. DC voltages are measured from point indicated to chassis ground using a Motorola DC multimeter or equivalent. Transmitter measurements should be made with a $1.2 \mu H$ choke in series with the voltage probe to prevent circuit loading.
3. Reference Designators are assigned in the following manner:

100 Series	=	Transmitter
200 Series	=	Frequency Generation
300 Series	=	Receiver
400/500 Series	=	Controller
600 Series	=	Keypad Board
4. Interconnect Tie Point Legend:

UNSWB+	=	Unswitch Battery Voltage (7.5V)
SWB+	=	Switch Battery Voltage (7.5V)
R5	=	Receiver Five Volts
CLK	=	Clock
Vdda	=	Regulated 3.3 Volts (for analog)
Vddd	=	Regulated 3.3 Volts (for digital)
CSX	=	Chip Select Line (not for LVZIF)
SYN	=	Synthesizer
DACRX	=	Digital to Analog Voltage (For Receiver Front End Filter)
VSF	=	Voltage Super Filtered (5 volts)
VR	=	Voltage Regulator

6-LAYER CIRCUIT BOARD DETAIL VIEWING COPPER STEPS IN PROPER LAYER SEQUENCE

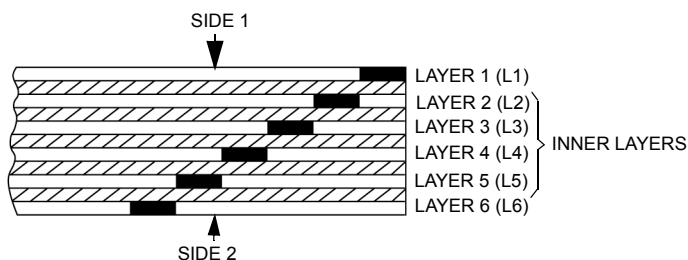

THIS PAGE INTENTIONALLY LEFT BLANK

8.0 Circuit Board/Schematic Diagrams and Parts List

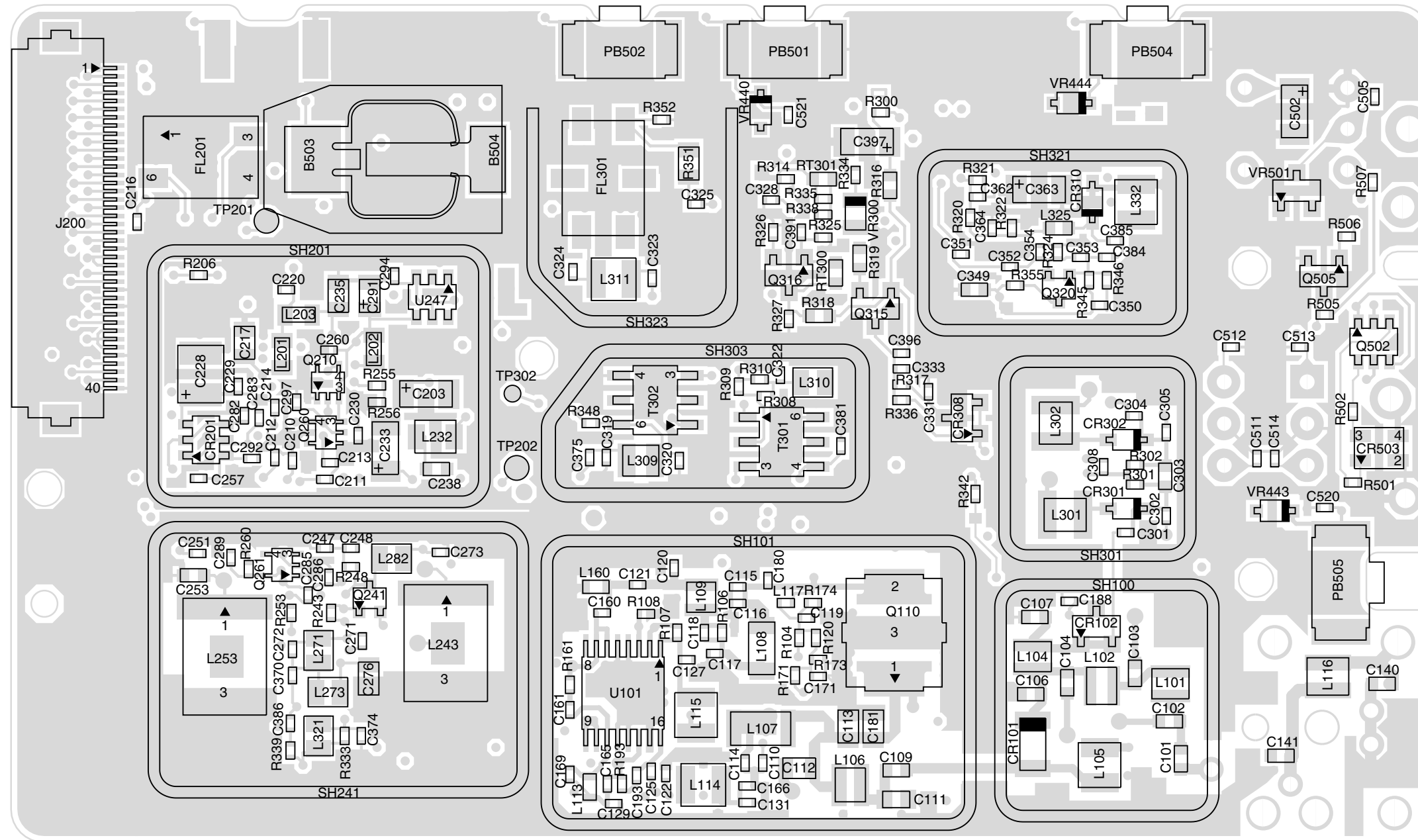

330-400MHz Main Board Top Side PCB No. 8404101G02/G03/G04

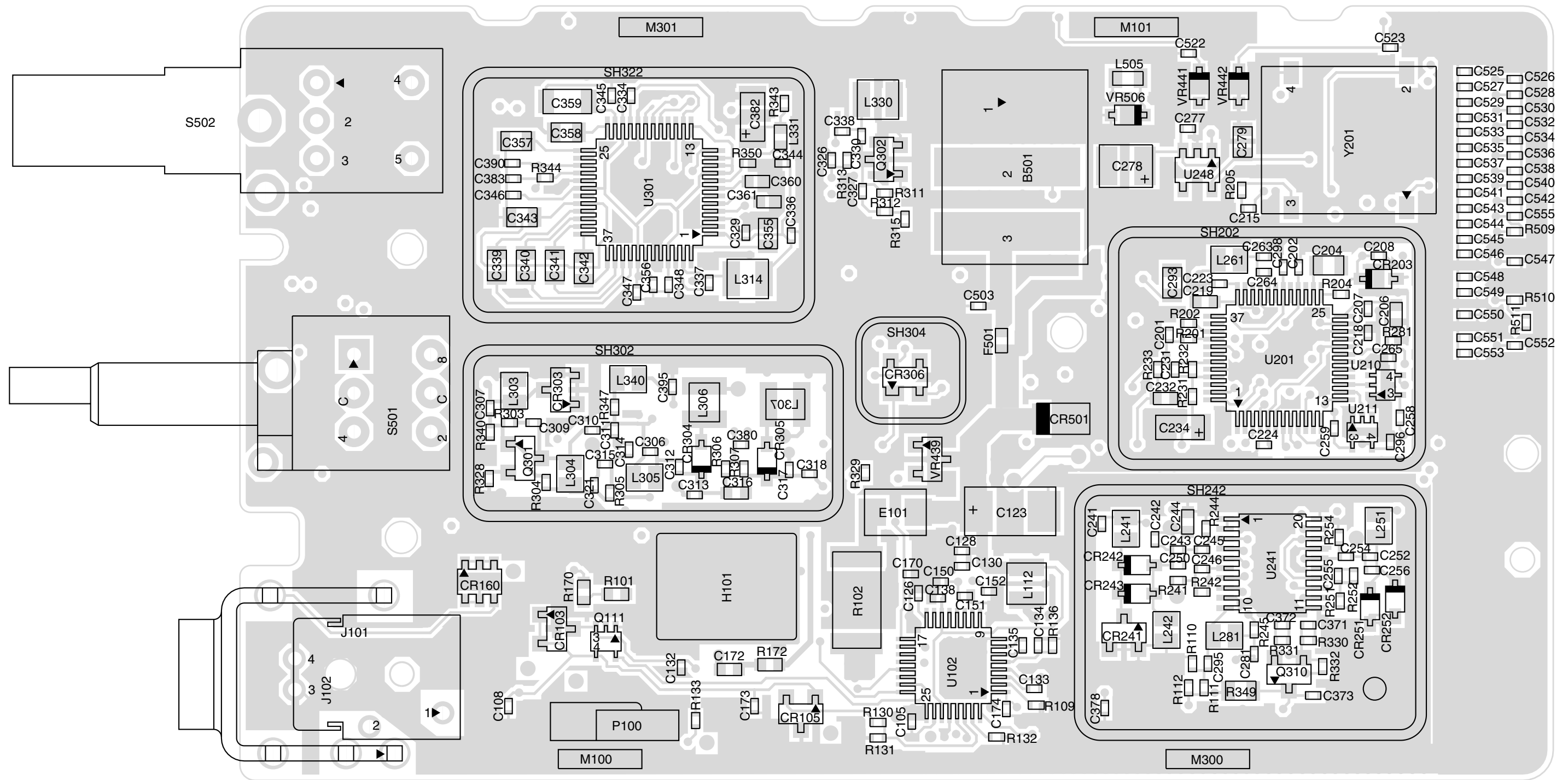

- C525
- C526
- C527
- C528
- C529
- C530
- C531
- C532
- C533
- C534
- C535
- C536
- C537
- C538
- C539
- C540
- C541
- C542
- C543
- C544
- C545
- C546
- C547
- C548
- C549
- C550
- C551
- C552
- C553

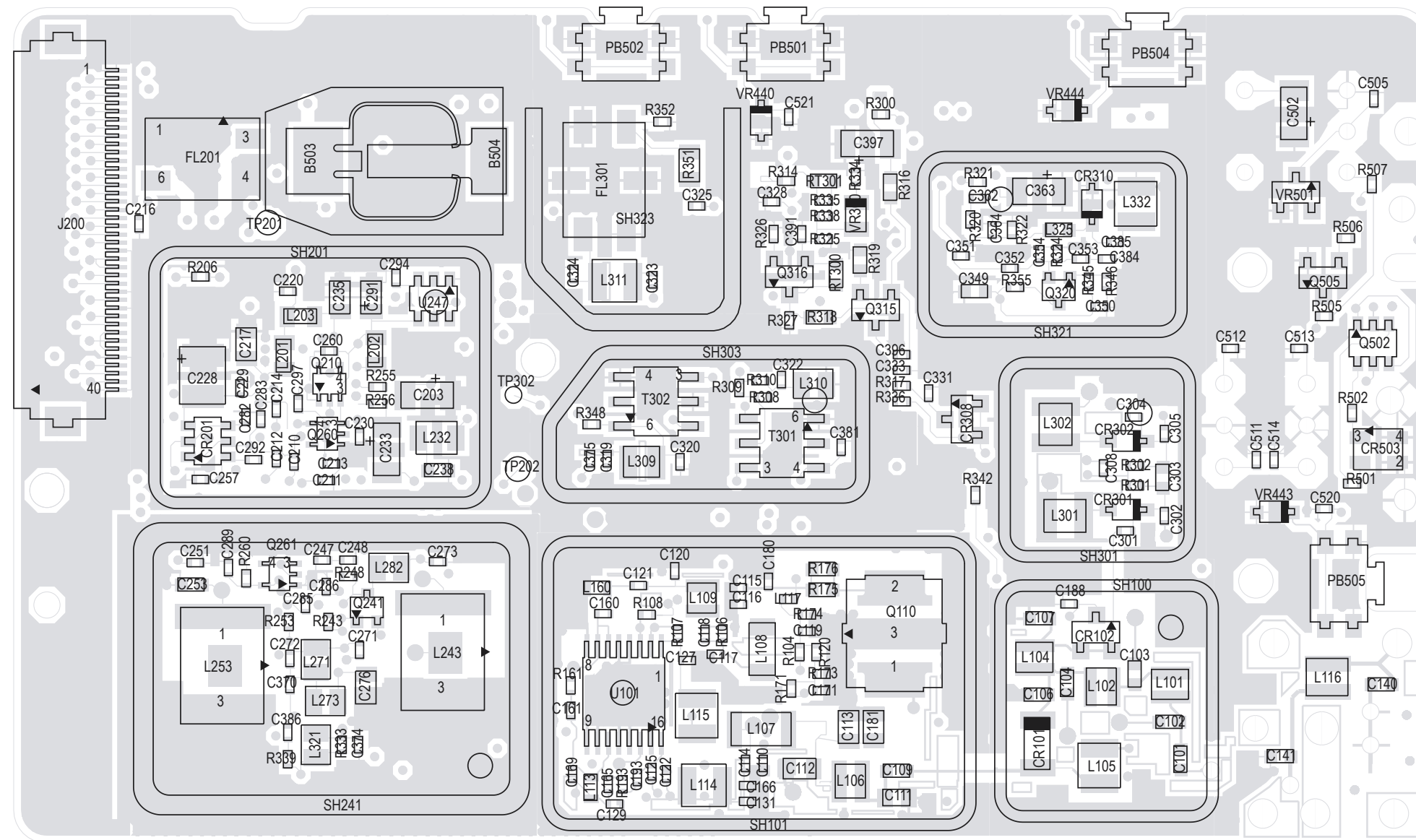

ZMY0131018-O

330-400MHz Main Board Top Side PCB No. 8404101G06

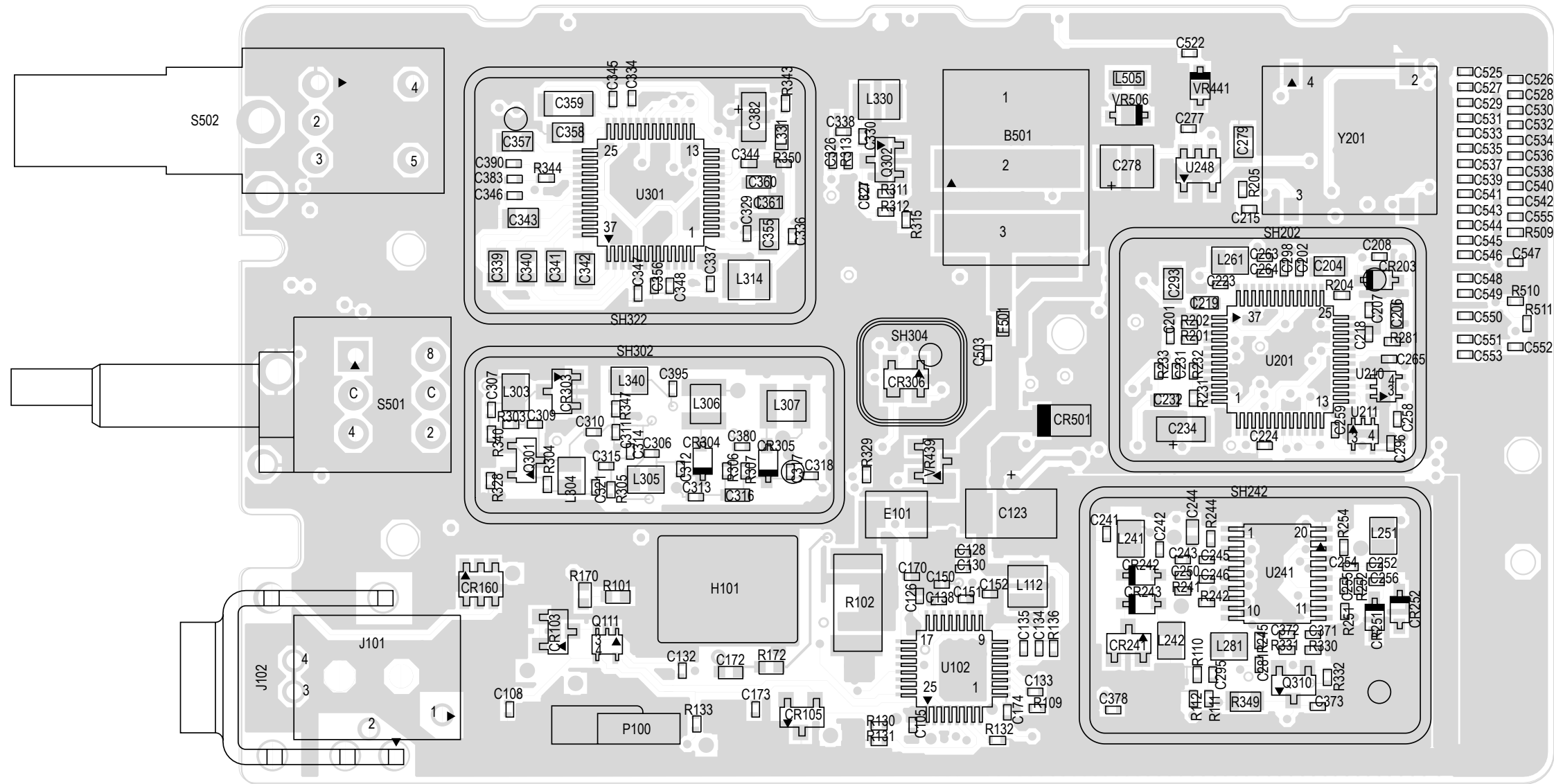

ZMY0131019-O

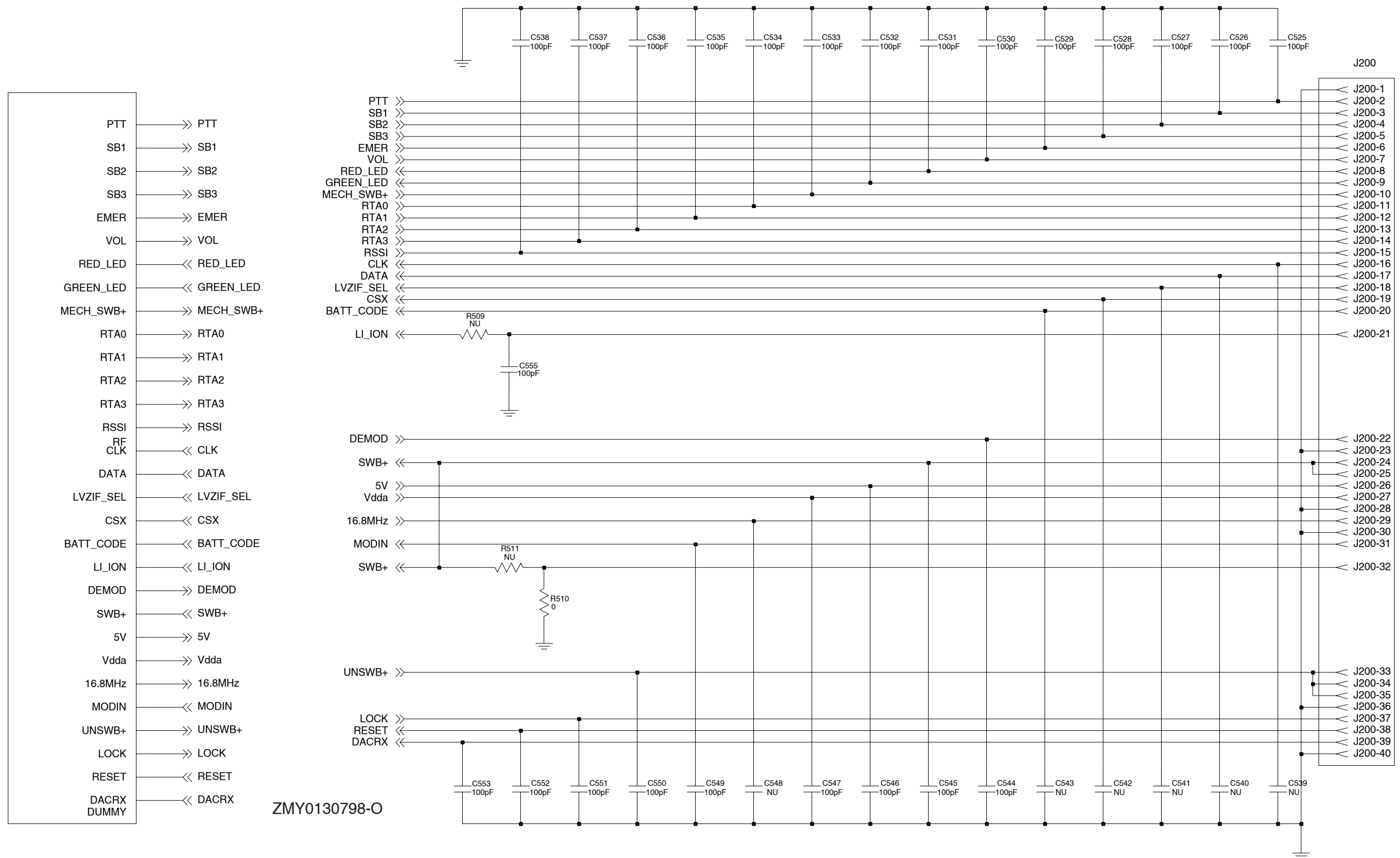

ZMY0130798-O

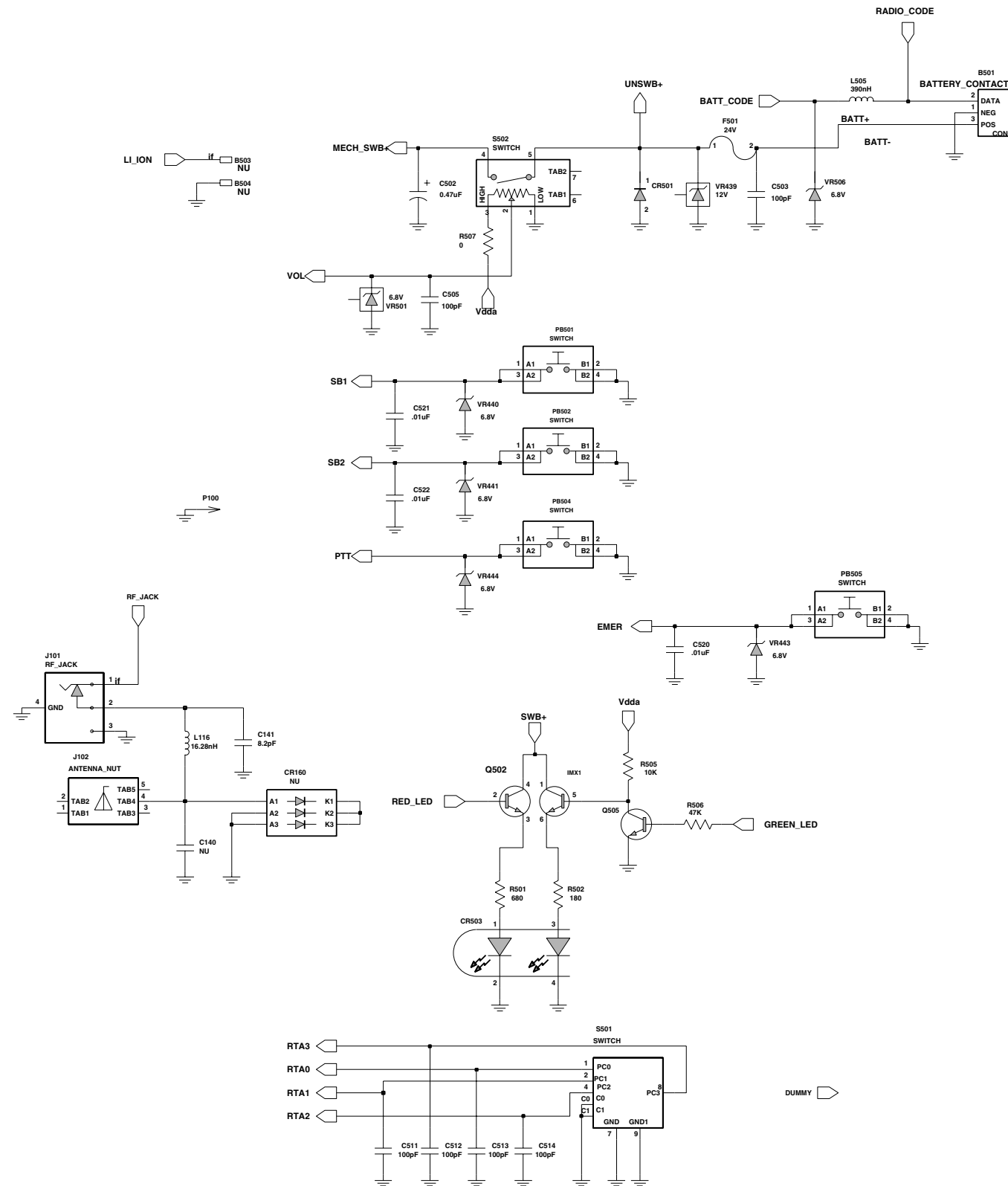

330-400MHz Controls And Switches Schematic Diagram (sheet 2 of 2)

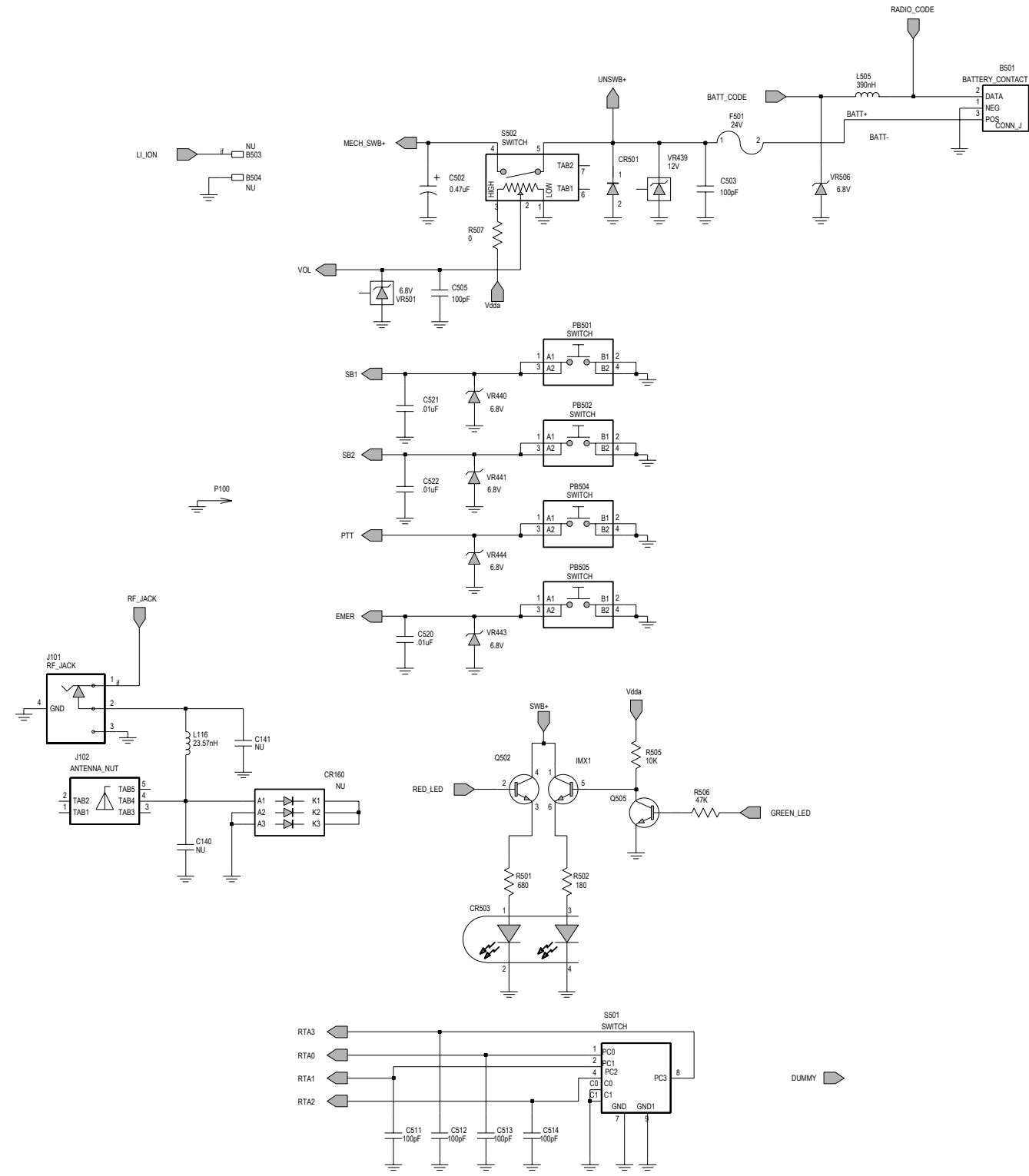

ZMY01301003-O

**330-400MHz Controls And Switches Schematic Diagram
(sheet 2 of 2 for 8404101G06 PCB)**

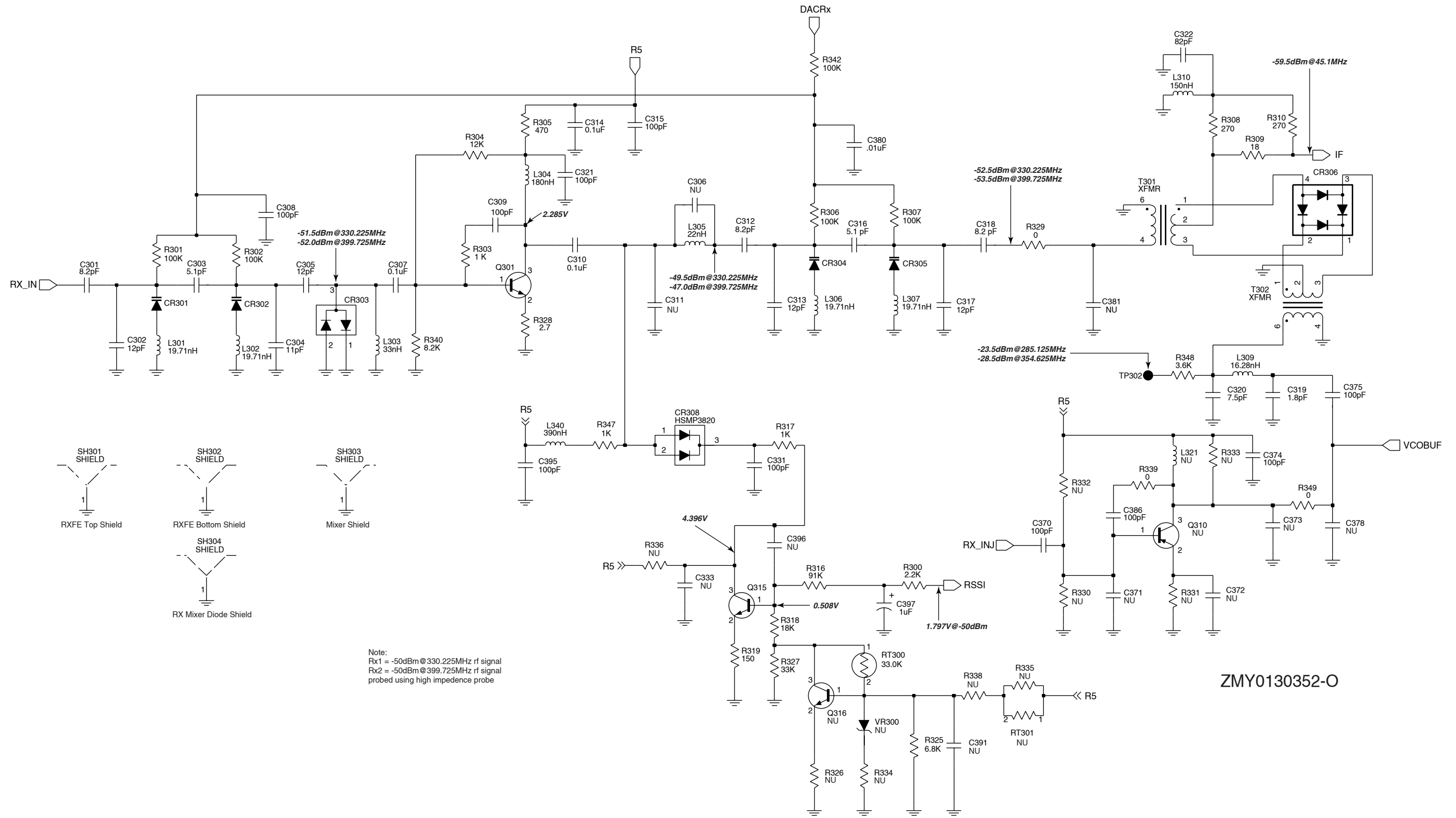

330-400MHz Receiver Front End Schematic Diagram

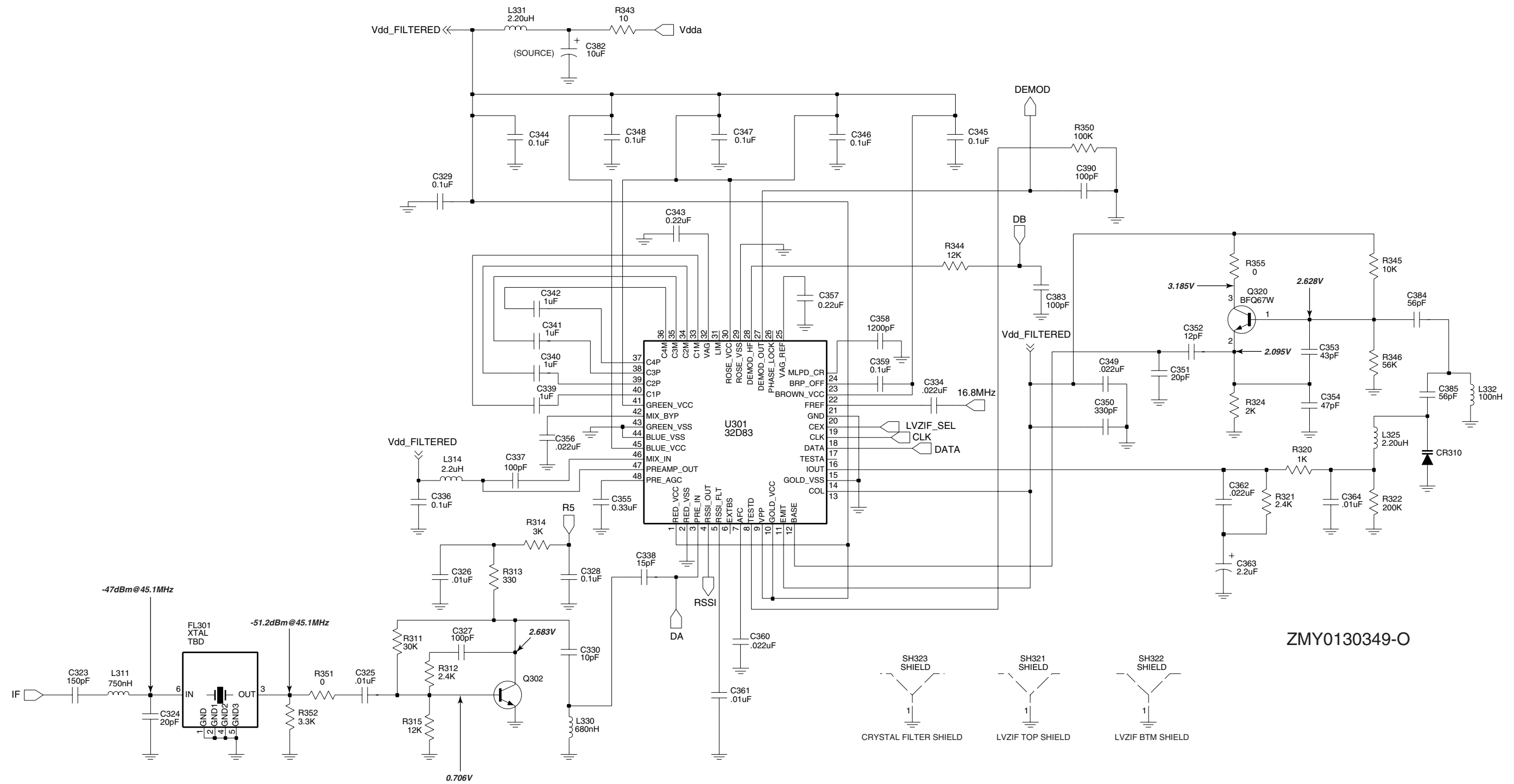

ZMY0130349-O

330-400MHz Receiver Back End Schematic Diagram

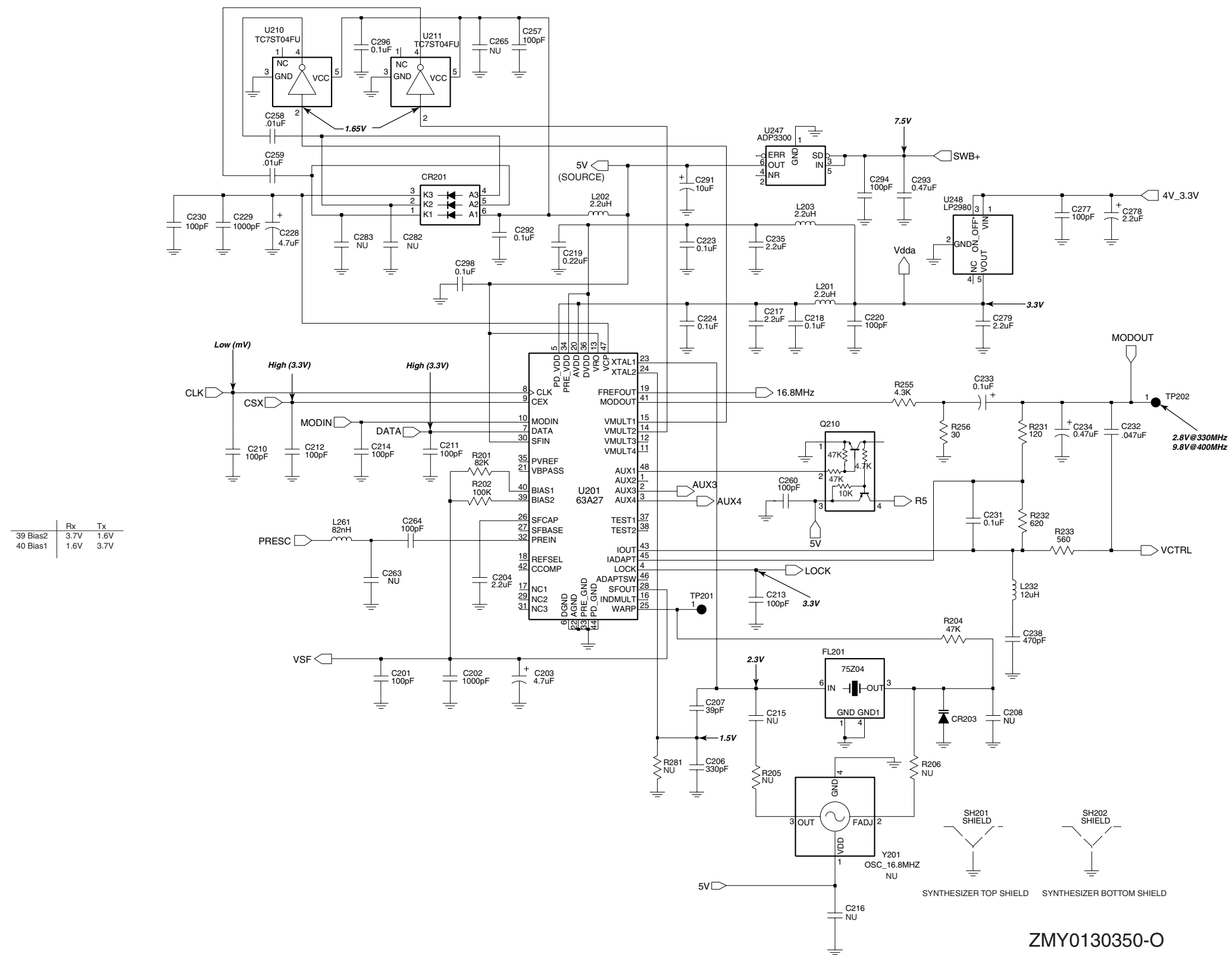

ZMY0130350-O

330-400MHz Synthesizer Schematic Diagram

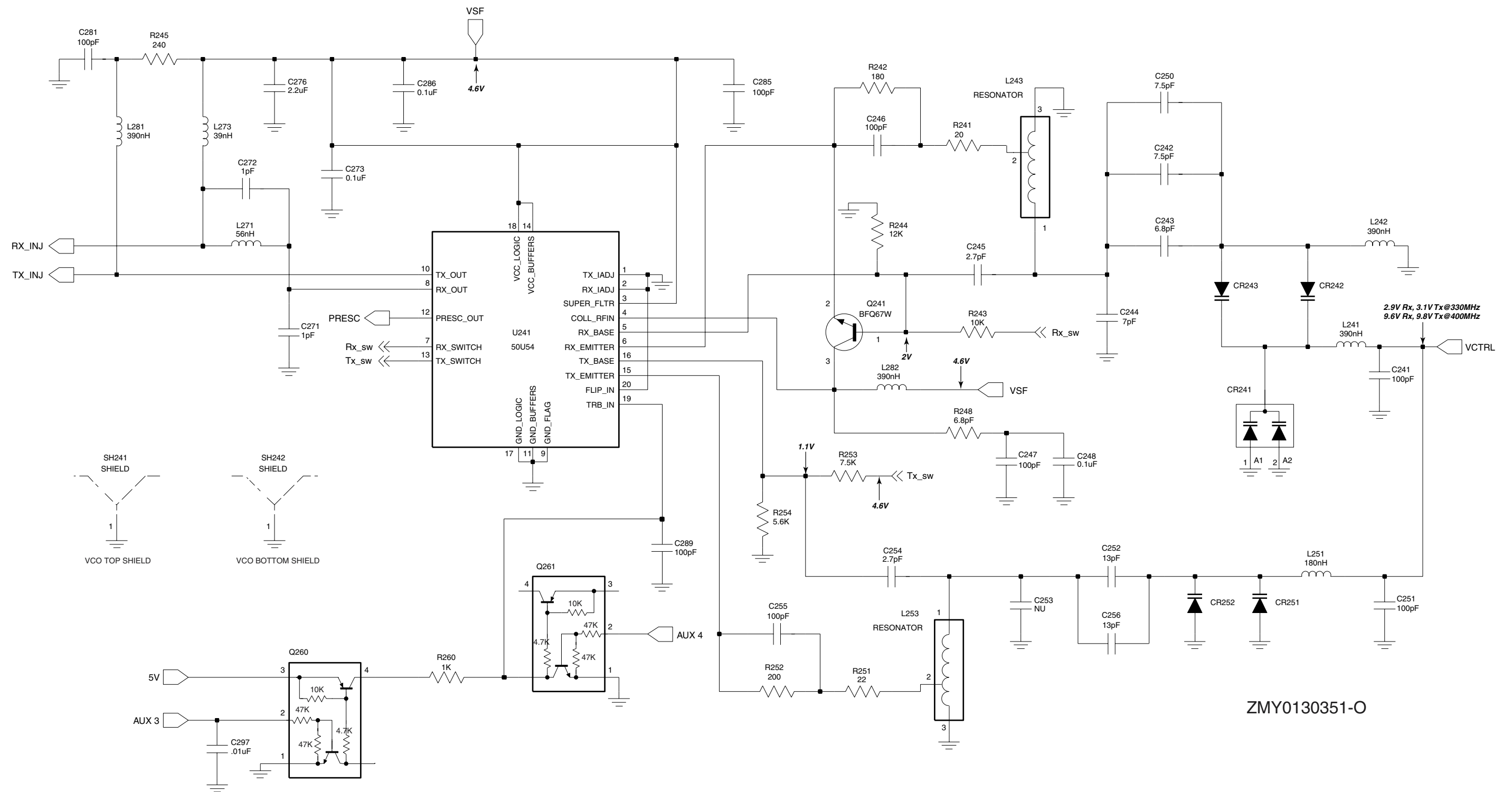

330-400MHz Voltage Controlled Oscillator Schematic Diagram

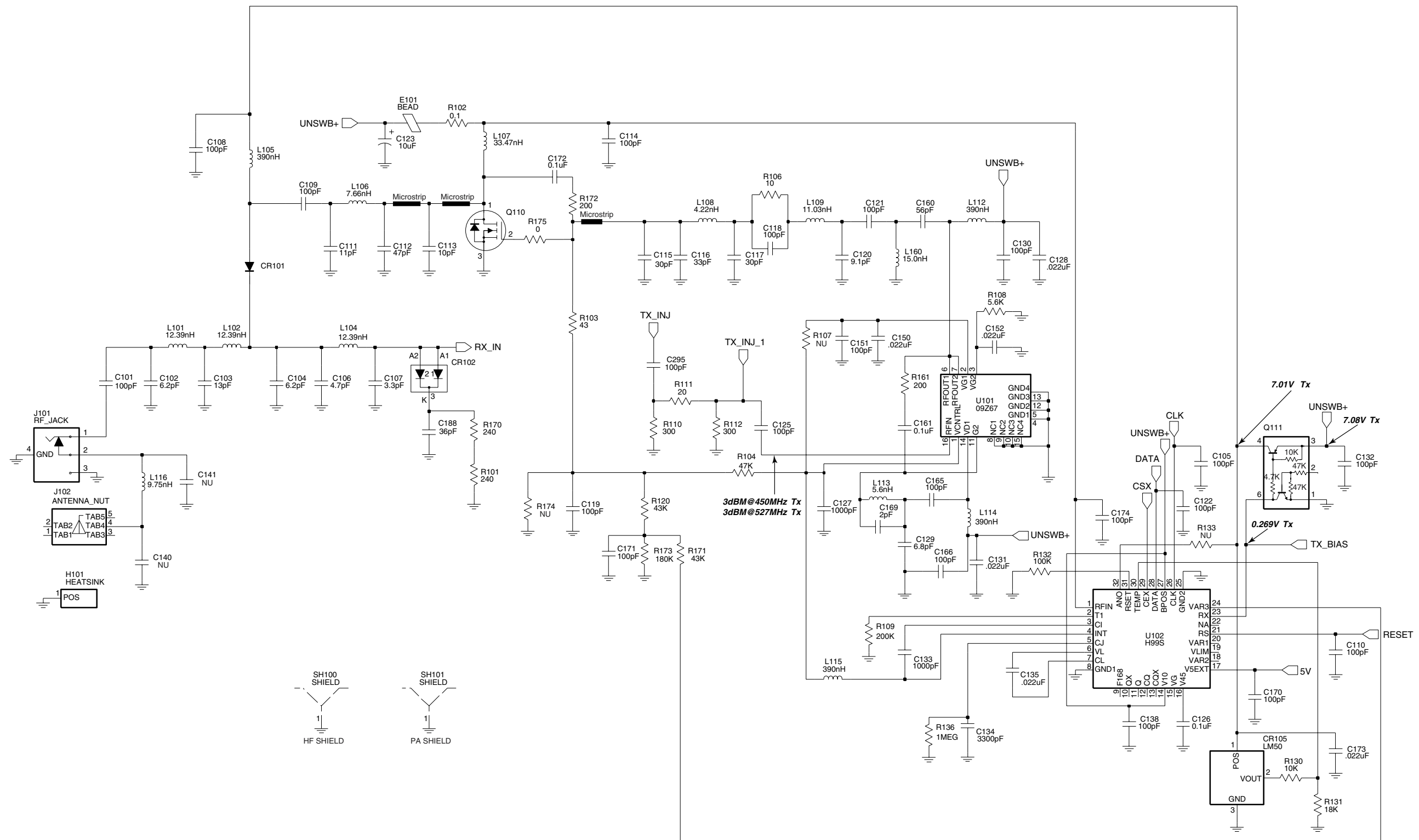

ZMY0130353-A

330-400MHz Transmitter Schematic Diagram

330-400MHz Radio Parts List (RF Board)

Circuit Ref	Motorola Part No.	Description
B501	0986237A02	Battery Contact Module
B503	3980502Z01	Backup Battery Contact, B+ (not used in GP328 Plus)
B504	3980501Z01	Backup Battery Contact, B- (not used in GP328 Plus)
C101	2113740F51	100pF
C102	2113740F27	6.2pF
C103	2113740F32	10pF
C104	2113740F27	6.2pF
C105	2113743L05	100pF
C106	2113740F19	4.7pF
C107	2113740F15	3.3pF
C108	2113743L05	100pF
C109	2113740F51	100pF
C110	2113743L05	100pF
C111	2103689A46	13pF
C112	2180605Z34	47pF
C113	2180605Z16	10pF
C114	2113743L05	100pF
C115	2113743N26	10pF
C116	2113743N26	10pF
C117	2113743N36	27pF
C118	2113743N50	100pF
C119	2113743L05	100pF
C120	2113743N25	9.1pF
C121	2113743N50	100pF
C122	2113743L05	100pF
C123	2311049A18	10uF
C125	2113743N50	100pF
C126	2113743M24	0.1uF
C127	2113743L17	1000pF
C128	2113743M08	0.022uF
C129	2113743N33	7.5pF
C130	2113743L05	100pF
C131	2113743M08	0.022uF
C132	2113743L05	100pF
C133	2113743L17	1000pF
C134	2113743L29	3300pF
C135	2113743M08	0.022uF
C138	2113743L05	100pF
C150	2113743M08	0.022uF
C151	2113743L05	100pF
C152	2113743M08	0.022uF
C160	2113743N50	100pF
C161	2113743M24	0.1uF
C165	2113743N50	100pF
C166	2113743L05	100pF

Circuit Ref	Motorola Part No.	Description
C169	2113743N30	15pF
C170	2113743L05	100pF
C171	2113743L05	100pF
C172	2113740F50	100uF
C173	2113743M08	0.022uF
C174	2113743L05	100pF
C180	2113743N26	10pF
C188	2113743N50	100pF
C193	2113743M24	0.1uF
C201	2113743N50	100pF
C202	2113743L17	1000pF
C203	2311049A56	4.7uF
C204	2104993J02	2.2uF
C206	2113740F63	330pF
C207	2113743N40	56pF
C210	2113743N50	100pF
C211	2113743N50	100pF
C212	2113743N50	100pF
C213	2113743N50	100pF
C214	2113743N50	100pF
C217	2104993J02	2.2uF
C218	2113743M24	0.1uF
C219	2113743K16	0.22uF
C220	2113743N50	100pF
C223	2113743M24	0.1uF
C224	2113743M24	0.1uF
C228	2311049J11	4.7uF
C229	2113743L17	1000pF
C230	2113743N50	100pF
C231	2113743M24	0.1uF
C232	2113743E12	0.047uF
C233	2311049A01	0.1uF
C234	2311049A05	0.47uF
C235	2104993J02	2.2uF
C238	2113741F17	470pF
C241	2113743N50	100pF
C242	2113743N23	7.5pF
C243	2113743N22	6.8pF
C244	2113740F13	2pF
C245	2113743N12	2.7pF
C246	2113743N50	100pF
C247	2113743N50	100pF
C248	2113743M24	0.1uF
C250	2113743N23	7.5pF
C251	2113743N50	100pF
C252	2113743N29	13.0pF
C254	2113743N12	0.047uF
C255	2113743N50	100pF
C256	2113743N29	13.0pF
C257	2113743N50	100pF
C258	2113743L41	0.01uF

Circuit Ref	Motorola Part No.	Description
C259	2113743L41	0.01uF
C260	2113743N50	100pF
C264	2113743N50	100pF
C271	2113743N03	1.0pF
C272	2113743N03	1.0pF
C273	2113743M24	0.1uF
C276	2104993J02	2.2uF
C277	2113743N50	100pF
C278	2311049A09	2.2uF
C279	2104993J02	2.2uF
C281	2113743N50	100pF
C285	2113743N50	100pF
C286	2113743M24	0.1uF
C289	2113743N50	100pF
C291	2311049A69	10uF
C292	2113743M24	0.1uF
C293	2113743A27	0.47uF
C294	2113743N50	100pF
C295	2113743N50	100pF
C296	2113743M24	0.1uF
C297	2113743L41	0.01uF
C298	2113743M24	0.1uF
C301	2113743N24	8.2pF
C302	2113743N28	12pF
C303	2113740L11	5.1pF
C304	2113743N27	11.0pF
C305	2113743N28	12pF
C306	2113743N22	6.8pF
C307	2113743M24	0.1uF
C308	2113743N50	100pF
C309	2113743N50	100pF
C310	2113743M24	0.1pF
C312	2113743N24	8.2pF
C313	2113743N27	11.0pF
C314	2113743M24	0.1pF
C315	2113743N50	100pF
C316	2113740L11	5.1pF
C317	2113743N27	11pF
C318	2113743N24	8.2pF
C319	2113743N21	6.2pF
C320	2113743N20	5.6pF
C321	2113743N50	100pF
C322	2113743N48	82pF
C323	2113743N54	150pF
C324	2113743N33	20pF
C325	2113743L41	0.01uF
C326	2113743L41	0.01uF
C327	2113743N50	100pF
C328	2113743M24	0.1pF
C329	2113743M24	0.1pF
C330	2113743N26	10pF

Circuit Ref	Motorola Part No.	Description
C331	2113743N50	100pF
C334	2113743M08	0.022uF
C336	2113743M24	0.1pF
C337	2113743N50	100pF
C338	2113743N30	15pF
C339	2180478Z20	1.0uF
C340	2180478Z20	1.0uF
C341	2180478Z20	1.0uF
C342	2180478Z20	1.0uF
C343	2113743A23	0.22uF
C344	2113743M24	0.1pF
C345	2113743M24	0.1pF
C346	2113743M24	0.1pF
C347	2113743M24	0.1pF
C348	2113743M24	0.1pF
C349	2113743E07	0.022uF
C350	2113743L05	330pF
C351	2113743N33	20pF
C352	2113743N28	12.0pF
C353	2113743N41	43.0pF
C354	2113743N42	47.0pF
C355	2113743A24	0.330uF
C356	2113743M08	0.022uF
C357	2113743A23	0.22uF
C358	2113741A23	1200pF
C359	2109720D14	0.1uF
C360	2113743E07	0.022uF
C361	2113741F49	10nF
C362	2113743M08	0.022uF
C363	2311049A40	2.2uF
C364	2113743L41	0.01uF
C370	2113743N50	100pF
C374	2113743N50	100pF
C375	2113743N50	100pF
C380	2113743L41	0.01uF
C382	2311049A59	10uF
C383	2113743N50	100pF
C384	2113743N44	56pF
C385	2113743N44	56pF
C386	2113743N50	100pF
C390	2113743N50	100pF
C395	2113743N50	100pF
C397	2311049A07	1.0uF
C502	2311049A05	0.47uF
C503	2113743N50	100pF
C505	2113743N50	100pF
C511	2113743N50	100pF
C512	2113743N50	100pF
C513	2113743N50	100pF
C514	2113743N50	100pF
C520	2113743L41	0.01uF

Circuit Ref	Motorola Part No.	Description	Circuit Ref	Motorola Part No.	Description	Circuit Ref	Motorola Part No.	Description	Circuit Ref	Motorola Part No.	Description
C521	2113743L41	0.01uF	FL201	**4805875Z04	16.8MHZ Xtal	L340	2462587V41	390nH	R176	0662057B59	3 ohm
C522	2113743L41	0.01uF	FL301	4802245J43	Xtal Filter 45.1Mhz	L400	2462587Q42	390NH	R193	0662057M57	200
C523	2113743L41	0.01uF	H101	2680499Z01	Heat Spreader	L401	2462587Q42	390NH	R201	0662057N21	82K
C525	2113743N50	100pF	J101	0985613Z01	RF Jack Assembly	L410	2462587Q42	390NH	R202	0662057N23	100K
C526	2113743N50	100pF	J102	0280519Z02	Antenna Nut (Ref: 0280519Z04)	L411	2462587Q42	390NH	R204	0662057N15	47K
C527	2113743N50	100pF	J200	0905505Y04	CONN ZIF HORIZONTAL	L505	2462587Q42	390nH	R231	0662057M52	120
C528	2113743N50	100pF	L101	2479990B02	19.61nH	P100	3905643V01	Gnd Contact Finger	R232	0662057M69	620
C529	2113743N50	100pF	L102	2479990B02	19.61nH	PB501	4070354A01	Tactile, PushButton	R233	0662057M68	560
C530	2113743N50	100pF	L104	2479990B02	19.61nH	PB502	4070354A01	Tactile, PushButton	R241	0662057M33	20
C531	2113743N50	100pF	L105	2462587N22	390nH	PB504	4070354A01	Tactile, PushButton	R242	0662057M56	180
C532	2113743N50	100pF	L106	2460591A19	8.71nH	PB505	4070354A01	Tactile, PushButton	R243	0662057M98	10K
C533	2113743N50	100pF	L107	2479990G01	33.47nH	PCB	6404103G02	330M PCB PANEL	R244	0662057N01	12K
C534	2113743N50	100pF	L108	0611077A01	4.22nH	PCB RF	8404101G02	330M RFPCB	R245	0662057M59	240
C535	2113743N50	100pF	L109	2479990B01	11.03nH	PCB Ctrl	8404051G07	330M Controller PCB	R248	0662057M37	30
C536	2113743N50	100pF	L112	2462587N50	56nH	Q110	4813828A09	TSTR 8W 450 MHz 7.5V	R251	0662057M34	22
C537	2113743N50	100pF	L113	2413926H09	5.6nH	Q111	4802245J50	Dual NPN/PNP	R252	0662057M57	200
C538	2113743N50	100pF	L114	2462587N45	22nH	Q210	4802245J50	Dual NPN/PNP	R253	0662057N03	15K
C545	2113743N50	100pF	L115	2462587N22	390nH	Q241	4805218N63	NPN	R254	0662057M92	5.6K
C546	2113743N50	100pF	L116	2460591C56	23.57nH	Q260	4802245J50	Dual NPN/PNP	R255	0662057M89	4.3K
C547	2113743N50	100pF	L117	2409154M17	22.0nH	Q261	4802245J50	Dual NPN/PNP	R256	0662057M37	30
C548	2113743N50	100pF	L160	2413926H14	15.0nH	Q301	4802245J44	NPN	R260	0662057M74	1K
C549	2113743N50	100pF	L201	2462587Q20	2.2uH	Q302	4802245J44	NPN	R300	0662057M82	2.2K
C550	2113743N50	100pF	L202	2462587Q20	2.2uH	Q315	4880214G02	NPN	R301	0662057N23	100K
C551	2113743N50	100pF	L203	2462587Q20	2.2uH	Q320	4805218N63	NPN	R302	0662057N23	100K
C552	2113743N50	100pF	L232	2462587P25	12uH	Q400	4809579E18	MOSFET P-CHAN	R303	0662057M74	100K
C553	2113743N50	100pF	L241	2462587V41	390nH	Q403	4813824A17	TSTR MMBT3906	R304	0662057N01	12K
C555	2113743N50	100pF	L242	2462587V41	390nH	Q405	4802245J54	Dual NPN	R305	0662057M66	470
CR101	4880973Z02	Pin Diode	L243	2460593C02	Teflon Resonator	Q410	4802245J54	Dual NPN	R306	0662057N23	100K
CR102	4802245J41	Pin Diode	L251	2462587V37	180nH	Q417	4802245J50	Dual NPN/PNP	R307	0662057N23	100K
CR103	4802245J41	Pin Diode	L253	2460593C02	Teflon Resonator	Q502	5180159R01	Dual NPN	R308	0662057M60	270
CR105	5185963A15	Temperature Sense	L261	2462587V33	82nH	Q505	4880214G02	NPN	R309	0662057M32	18
CR201	4802233J09	Triple Diode	L271	2462587V31	56nH	R101	0662057A34	240	R310	0662057M60	270
CR203	4862824C03	Varactor	L273	2462587V29	39nH	R102	0680735Z01	0.075	R311	0662057N10	30K
CR241	4805649Q13	Dual Varactor	L281	2462587V41	390nH	R104	0662057N15	47K	R312	0662057M83	2.4K
CR242	4802245J22	Varactor	L282	2462587V41	390nH	R106	0662057M26	10	R313	0662057M62	330
CR243	4802245J22	Varactor	L301	2460591D24	19.71nH	R108	0662057M92	5.6K	R314	0662057M85	3K
CR251	4862824C01	Varactor	L302	2460591D24	19.71nH	R109	0662057N30	200k	R315	0662057N01	12K
CR252	4862824C01	Varactor	L303	2462587V28	33nH	R110	0662057M61	300	R316	0662057N01	12K
CR301	4862824C01	Varactor	L304	2462587V37	180nH	R111	0662057M33	20	R317	0662057A96	91K
CR302	4862824C01	Varactor	L305	2462587V23	12nH	R112	0662057M61	300	R318	0662057A79	18K
CR303	4880154K03	Dual Common Anode-Cathode	L306	2460591D24	19.71nH	R120	0662057N14	43K	R319	0662057A29	150
CR304	4862824C01	Varactor	L307	2460591D24	19.71nH	R130	0662057M98	10K	R320	0662057M74	1K
CR305	4862824C01	Varactor	L309	2479990C02	16.28nH	R131	0662057N05	18K	R321	0662057M83	1K
CR306	4802245J42	Ring Quad Diode	L310	2462587V36	150nH	R132	0662057N33	270K	R322	0662057N30	1K
CR308	4802245J41	Pin Diode	L311	2462587N65	750nH	R136	0662057N47	1.0M 5%	R324	0662057M81	2K
CR310	4862824C01	Varactor	L314	2462587N72	2200nH	R161	0662057M57	200	R325	0662057M94	6.8K
CR501	4880107R01	Rectifier	L325	2480646Z20	2.20uH	R170	0662057A34	240	R327	0662057N11	33K
CR503	4805729G49	LED Red/Yel	L330	2462587N64	680nH	R171	0662057N14	5.6K	R328	0662057M12	2.7
E101	2484657R01	Ferrite Bead	L331	2480646Z20	2.2uH	R172	0662057A25	100 ohm	R329	0662057M01	0
F501	6580542Z01	Fuse 3A	L332	2462587N53	100nH	R173	0662057N29	180K	R339	0662057M01	0
						R175	0662057B59	3 ohm	R340	0662057M96	8.2K

Circuit Ref	Motorola Part No.	Description
R342	0662057N23	100K
R343	0662057M26	10
R344	0662057N01	12K
R345	0662057M98	10K
R346	0662057N17	56K
R347	0662057M74	1K
R348	0662057M87	3.6K
R349	0662057C01	0
R350	0662057N23	100K
R351	0662057C01	0
R352	0662057M86	3.3K
R355	0662057M01	0
R501	0662057M70	680
R502	0662057M56	180
R505	0662057M98	10K
R506	0662057N15	47K
R509	0662057M01	0
RT300	0680590Z01	THERMISTOR_33K
RT400	0680590Z01	Thermistor 33K
S501	4080710Z01	Channel Switch (Ref: 4080710Z09)
S502	1880619Z02	Volume Switch
SH100	2680507Z01	Harmonic Filter Shield
SH101	2680510Z01	PA Shield
SH201	2680511Z01	Synthesizer Top Shield
SH202	2680511Z01	Synthesizer Bottom Shield
SH241	2604120G01	VCO Top Shield
SH242	2680514Z01	VCO Bottom Shield
SH301	2680554Z01	Rx Pre-Filter Shield
SH302	2680555Z01	Rx Post-Filter
SH303	2680509Z01	Mixer Shield
SH304	2680624Z01	Mixer Diode Shield
SH321	2680508Z01	Zif 2nd Lo Shield
SH322	2680514Z01	Zif Shield
SH323	2604082P01	Xtal Filter Shield
T301	2580541Z02	XFMR Coil
T302	2580541Z02	XFMR Coil
U101	5185130C65	LDMOS Driver
U102	5185765B28	Power Control IC
U201	5185963A27	LVFRACN
U210	5102463J61	Inverter
U211	5102463J61	Inverter
U241	5105750U54	VCO Buffer
U247	5105739X05	Regulator Linear
U248	5102463J58	3.3V Regulator
U301	5109632D83	LVZIF
VR501	4813830A18	6.8V Zener

Circuit Ref	Motorola Part No.	Description
VR506	4802245J73	6.8 V Zener
	8404101G02	RF PCB
	8404101G03	RF PCB
	8404101G04	RF PCB
	8404101G06	RF PCB

* Motorola Depot Servicing only

** Not Serviceable

THIS PAGE INTENTIONALLY LEFT BLANK

9.0 Troubleshooting charts

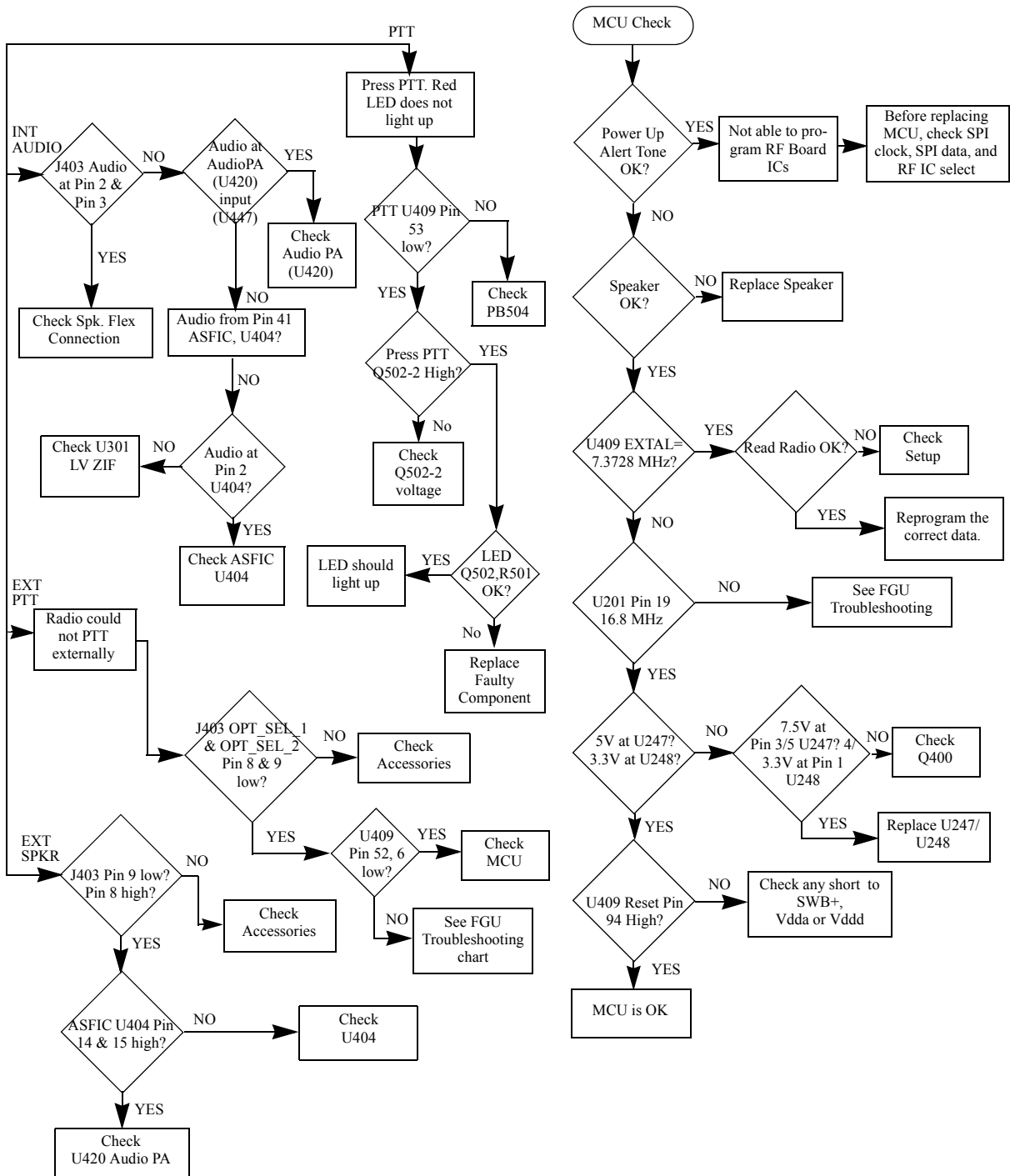

Troubleshooting Flow Chart for Controller

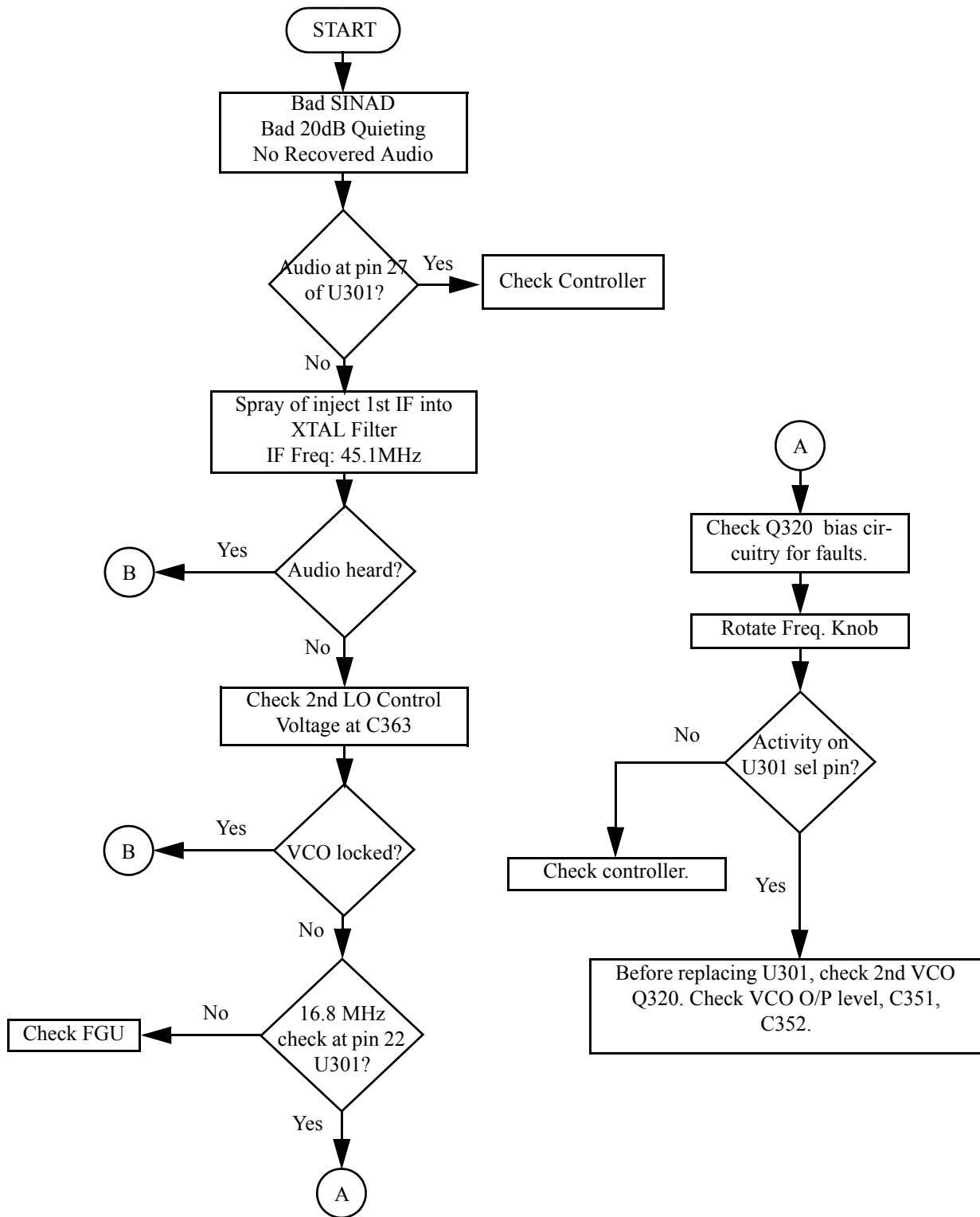

Troubleshooting Flow Chart for Receiver (Sheet 1 of 2)

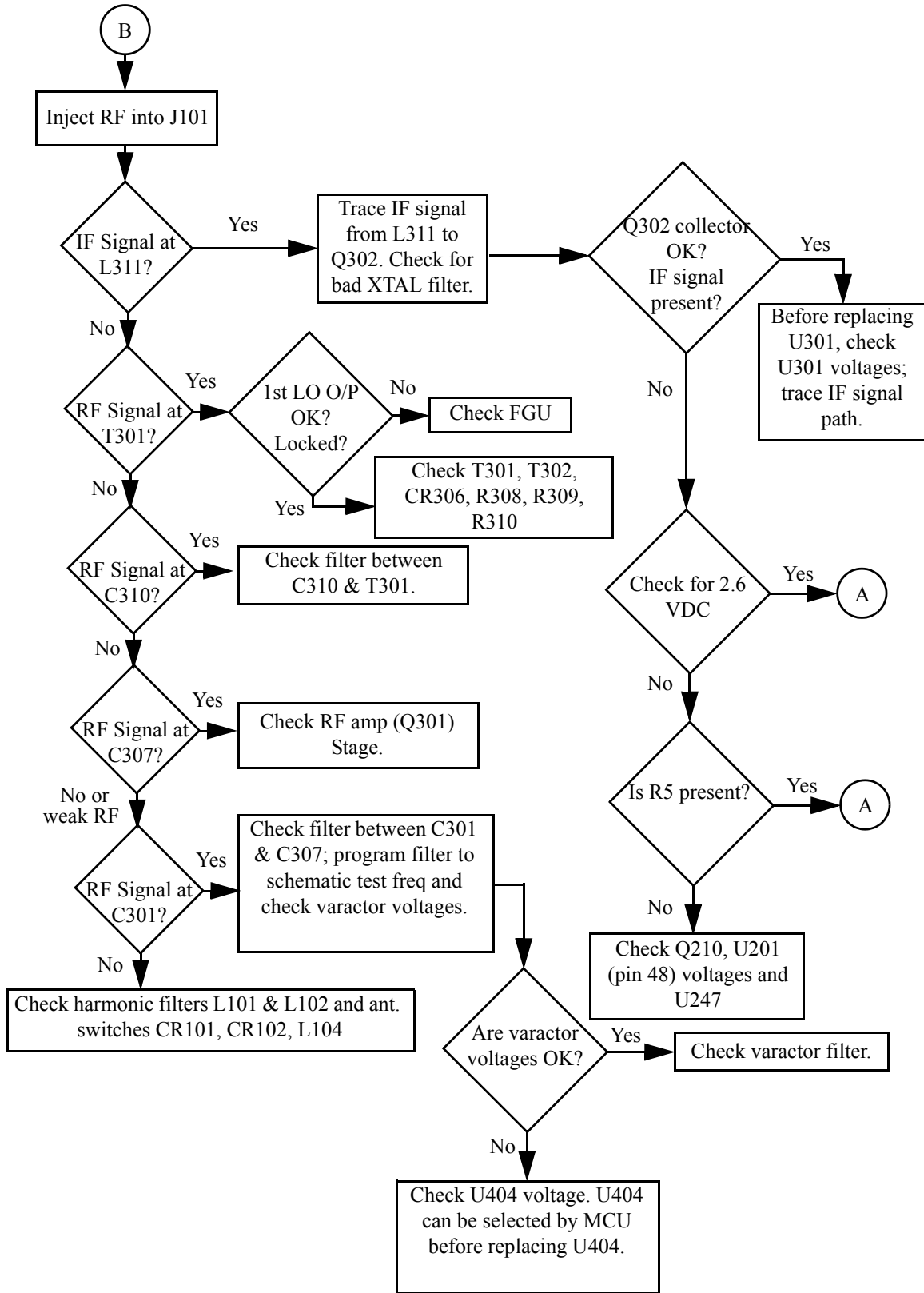

Troubleshooting Flow Chart for Receiver (Sheet 2 of 2)

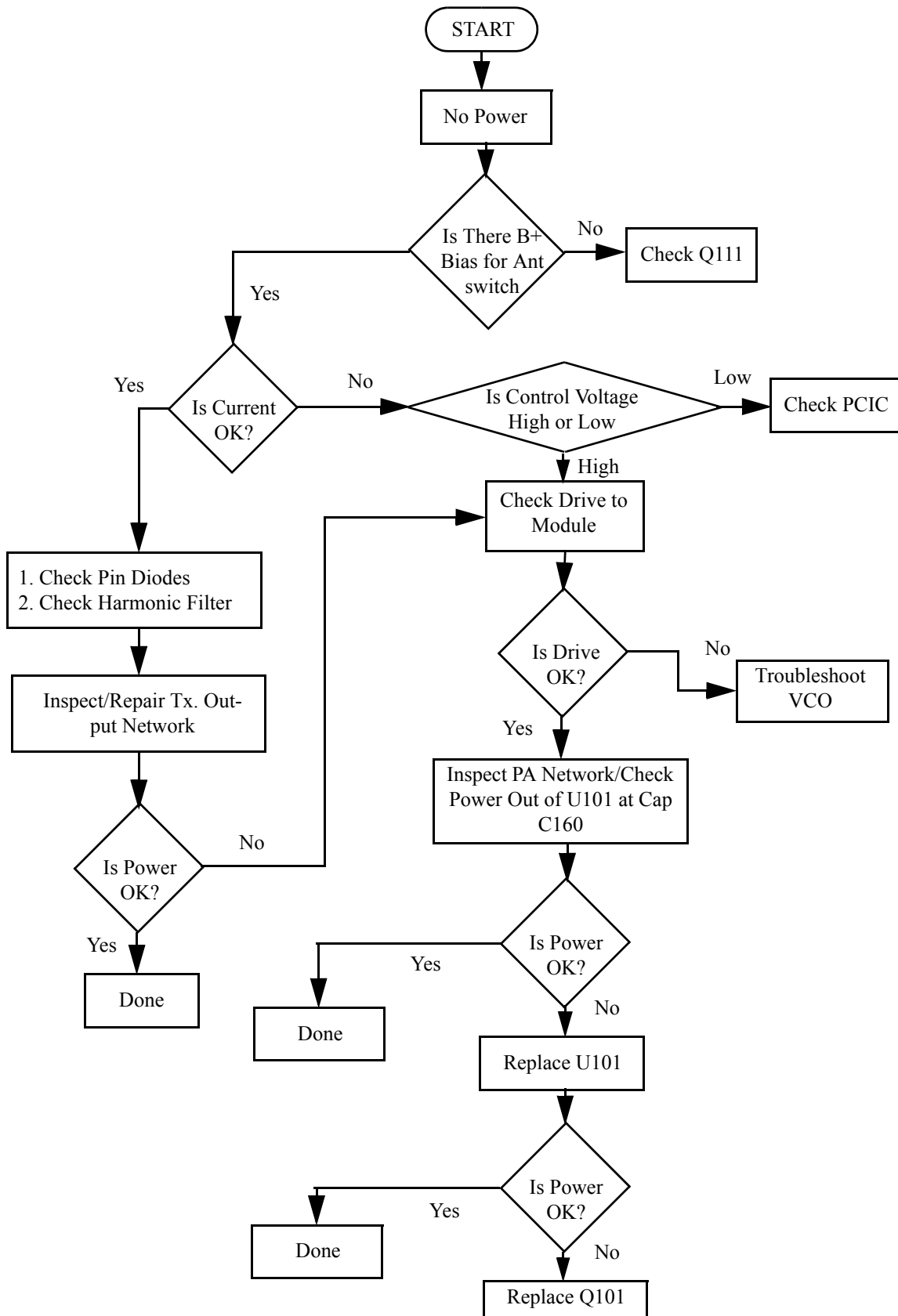

Troubleshooting Flow Chart for Transmitter

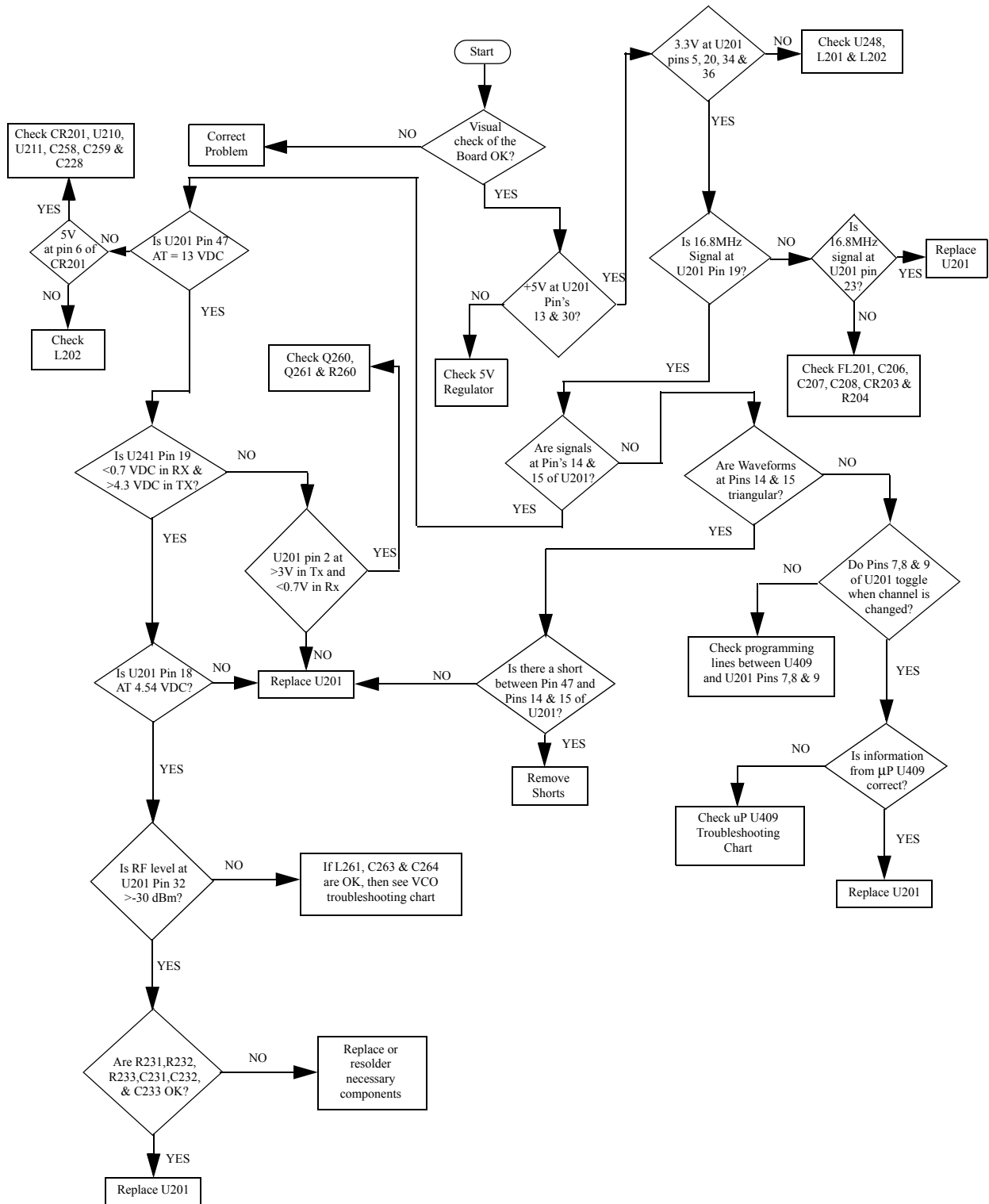

Troubleshooting Flow Chart for Synthesizer

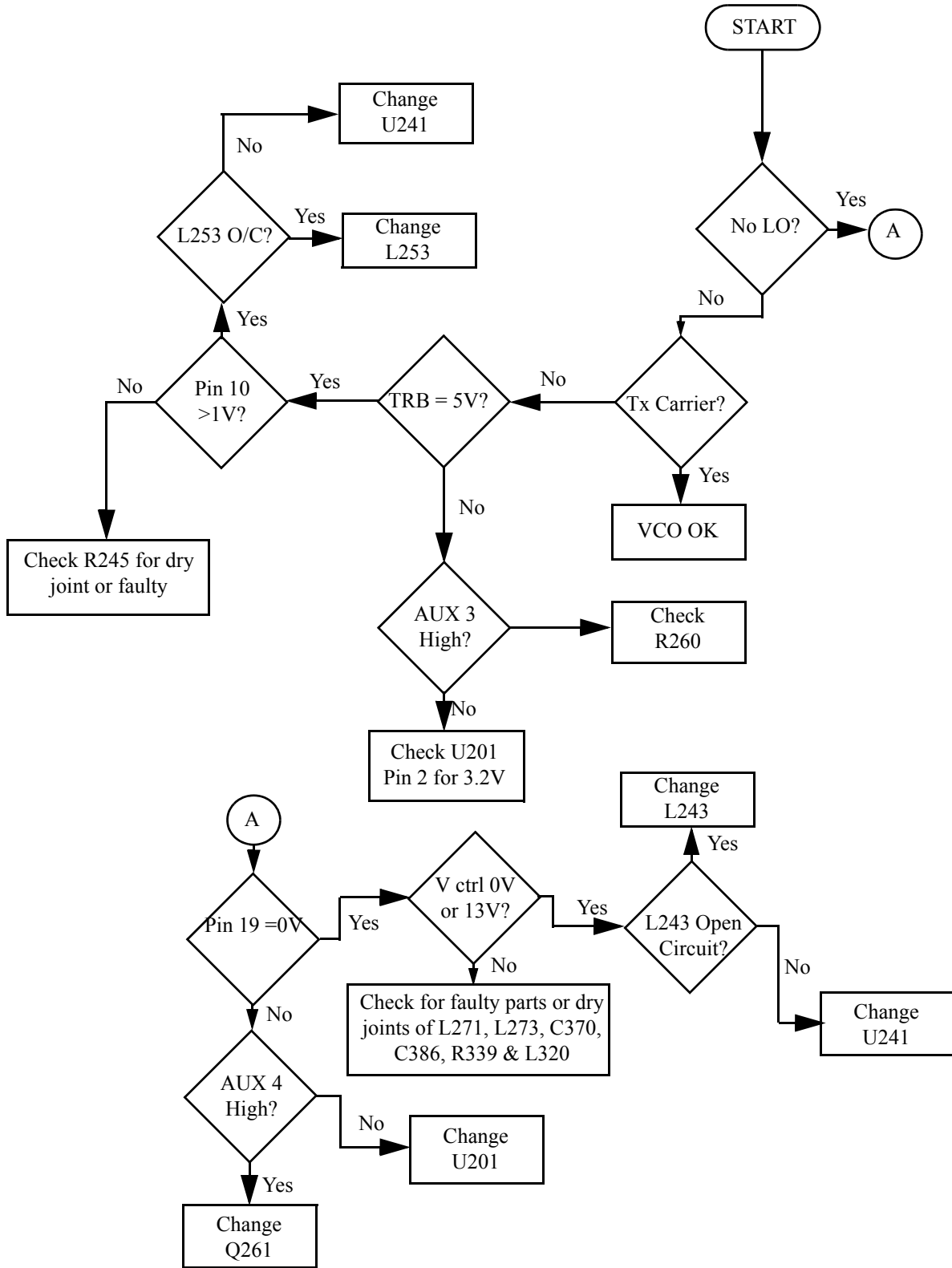

Troubleshooting Flow Chart for VCO

Section 6

FLEX LAYOUT/SCHEMATIC DIAGRAMS AND PARTS LISTS

1.0 RF-Controller Interconnect Flex

1.1 Rev A

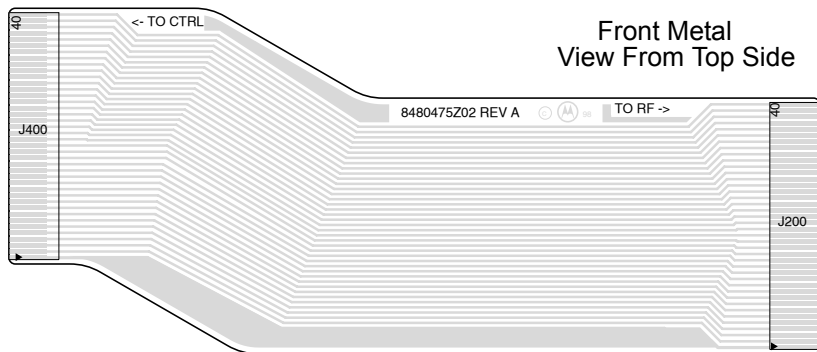

1.2 Rev B

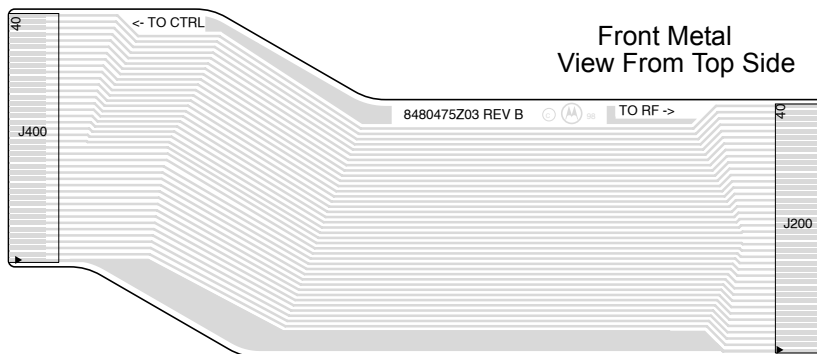

2.0 Schematic for RF-Controller Interconnect Flex

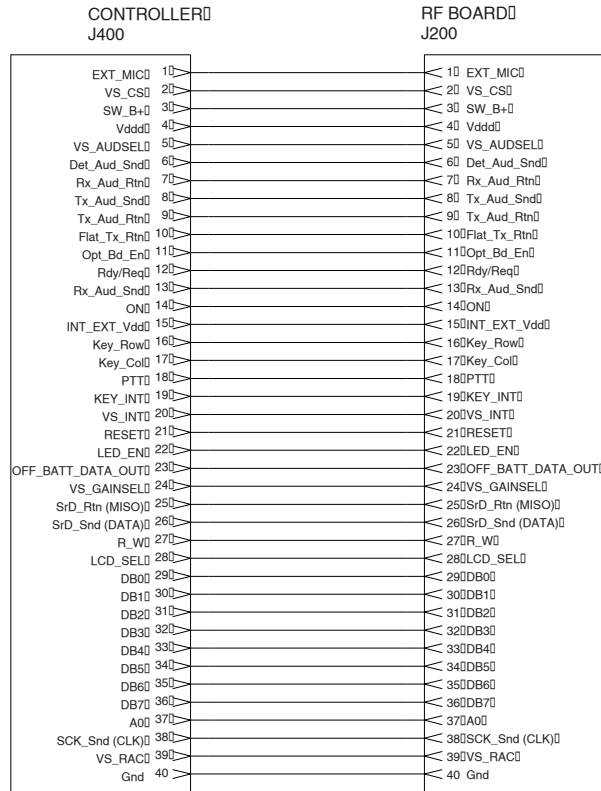

3.0 Universal Connector Flex

3.1 GP328 Plus

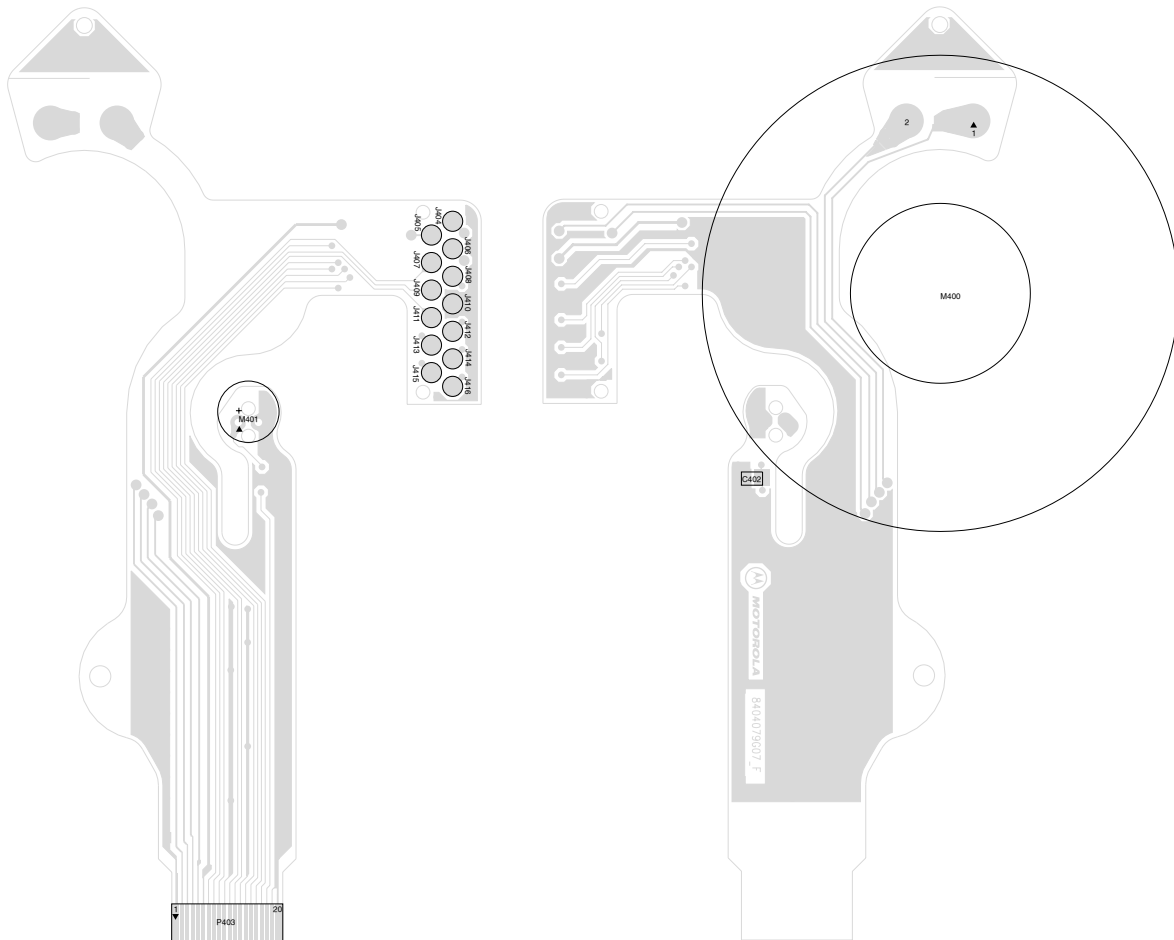

Front Metal
View From Front Side

Back Metal
View From Back Side

3.2 GP338 Plus/GP338 XLS

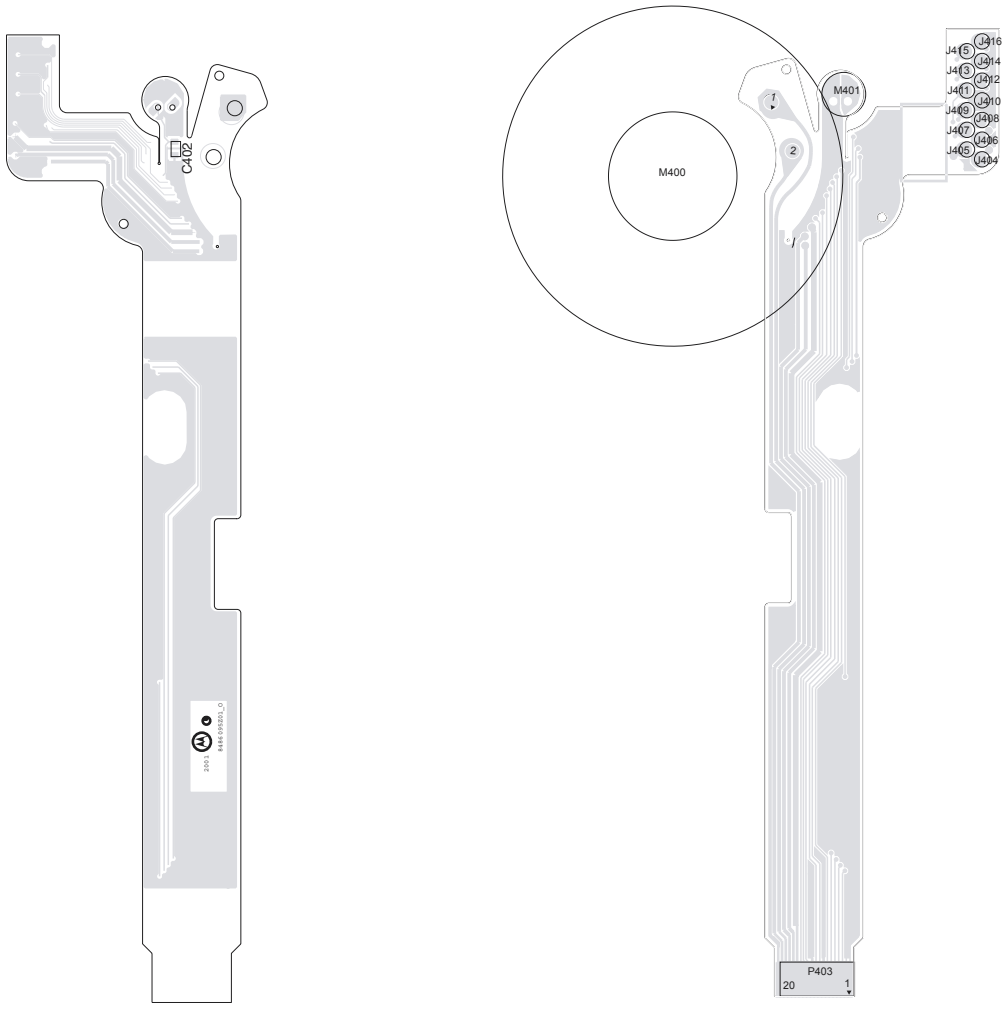

Front Metal
View From Front Side

Back Metal
View From Back Side

4.0 Schematic for Universal Connector Flex

4.1 GP328 Plus

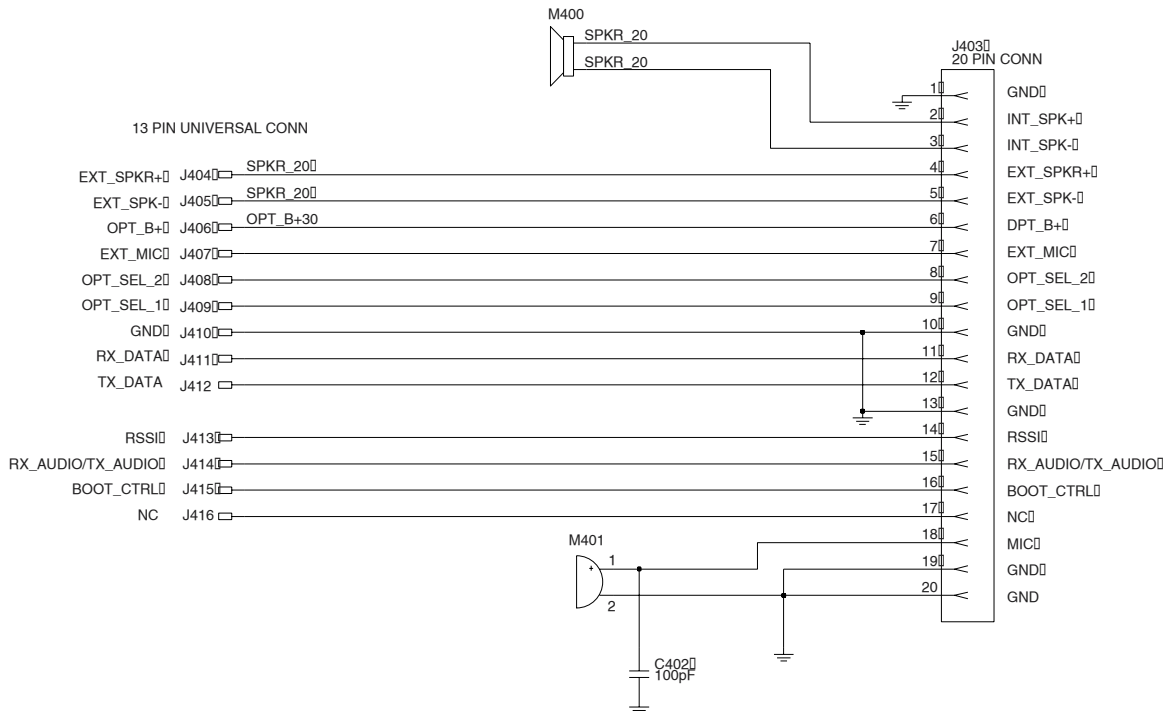

4.2 GP338 Plus/GP338 XLS

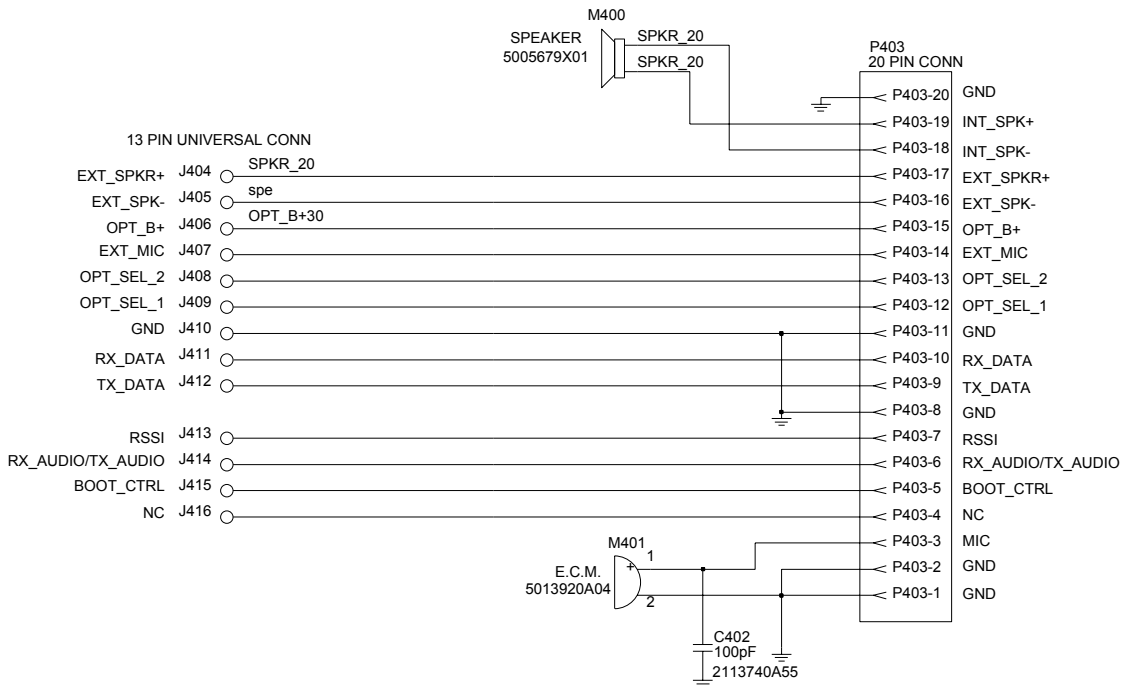

5.0 Parts List for Universal Connector Flex

5.1 GP328 Plus

Reference Symbol	Motorola Part No.	Description
C402	2113740A55	Cap, 100pF
M400	5005679X01	Speaker, 24 ohm
M401	5013920A04	Mic, Mini electrec

5.2 GP338 Plus/GP338 XLS

Reference Symbol	Motorola Part No.	Description
C402	2113740A55	Cap, 100pF
M400	5086094Z01	Speaker, 20 ohm
M401	5013920A04	Mic, Mini electrec

Technical Information Updates

As we continue to make engineering enhancements to our products, the information in our Service Manuals need to be updated accordingly. If you wish to be informed of these updates, kindly fill in and fax us your details.

Fax to: 6-04-6124944

**The Technical Publications Coordinator,
Media and Communications,
R&D Department,
Motorola Penang.**

Your Details

Name/Contact Person: _____

Company Name: _____

Address: _____

Telephone No.: _____

Fax No.: _____

Email Address: _____

How would you like to receive the update notification?

Through: mail email fax

Manual No.: 6804112J28

Kindly complete the Service Manual Feedback Form on the next page to help us ensure that you receive the most accurate and complete information.

Service Manual Feedback Form

We believe that reports from users provide valuable information for producing quality manuals. Kindly take a few moments to provide feedback on this manual. Thank you for your cooperation.

Fax to: 6-04-6124944

**The Technical Publications Coordinator,
Media and Communications,
R&D Department,
Motorola Penang.**

1. Please check all the appropriate boxes:

	Complete	Incomplete	Correct	Incorrect	Clear	Confusing	Size Adequate	Size Too Small	Not Covered in this Manual
Disassembly Procedures	<input type="checkbox"/>	<input type="checkbox"/>	<input type="checkbox"/>	<input type="checkbox"/>	<input type="checkbox"/>	<input type="checkbox"/>	<input type="checkbox"/>	<input type="checkbox"/>	<input type="checkbox"/>
Alignment Procedures	<input type="checkbox"/>	<input type="checkbox"/>	<input type="checkbox"/>	<input type="checkbox"/>	<input type="checkbox"/>	<input type="checkbox"/>	<input type="checkbox"/>	<input type="checkbox"/>	<input type="checkbox"/>
Exploded Views	<input type="checkbox"/>	<input type="checkbox"/>	<input type="checkbox"/>	<input type="checkbox"/>	<input type="checkbox"/>	<input type="checkbox"/>	<input type="checkbox"/>	<input type="checkbox"/>	<input type="checkbox"/>
Schematic Diagrams	<input type="checkbox"/>	<input type="checkbox"/>	<input type="checkbox"/>	<input type="checkbox"/>	<input type="checkbox"/>	<input type="checkbox"/>	<input type="checkbox"/>	<input type="checkbox"/>	<input type="checkbox"/>
Circuit Board Details	<input type="checkbox"/>	<input type="checkbox"/>	<input type="checkbox"/>	<input type="checkbox"/>	<input type="checkbox"/>	<input type="checkbox"/>	<input type="checkbox"/>	<input type="checkbox"/>	<input type="checkbox"/>
Electrical Parts List	<input type="checkbox"/>	<input type="checkbox"/>	<input type="checkbox"/>	<input type="checkbox"/>	<input type="checkbox"/>	<input type="checkbox"/>	<input type="checkbox"/>	<input type="checkbox"/>	<input type="checkbox"/>
Exploded View Parts List	<input type="checkbox"/>	<input type="checkbox"/>	<input type="checkbox"/>	<input type="checkbox"/>	<input type="checkbox"/>	<input type="checkbox"/>	<input type="checkbox"/>	<input type="checkbox"/>	<input type="checkbox"/>

2. How do you rate this particular Service Manual?

excellent very good good fair poor

3. Did this Service manual provide you with the information necessary to service and maintain the specific equipment?

very much so generally yes to some extent no

4. We would appreciate any corrections or recommendations for improving this manual. Please include the specific page number(s) of the diagram or procedure in question.

5. General comments/suggestions:

Manual No.: 6804112J28